

# User's Manual

For

# AM882

## Fully Digital Stepping Drive

Version 1.0

©2010 All Rights Reserved

Attention: Please read this manual carefully before using the drive!



The content in this manual has been carefully prepared and is believed to be accurate, but no responsibility is assumed for inaccuracies.

Leadshine reserves the right to make changes without further notice to any products herein to improve reliability, function or design. Leadshine does not assume any liability arising out of the application or use of any product or circuit described herein; neither does it convey any license under its patent rights of others.

Leadshine's general policy does not recommend the use of its products in life support or aircraft applications wherein a failure or malfunction of the product may directly threaten life or injury. According to Leadshine's terms and conditions of sales, the user of Leadshine's products in life support or aircraft applications assumes all risks of such use and indemnifies Leadshine against all damages.



**Leadshine Technology Co., Ltd.**

3/F, Block 2, Nanyou Tianan Industrial Park, Nanshan Dist, Shenzhen, China

T: (86)755-26434369

F: (86)755-26402718

Web site: [www.leadshine.com](http://www.leadshine.com)

E-Mail: [sales@leadshine.com](mailto:sales@leadshine.com)

©2010 by Leadshine Technology Company Limited.  
All Rights Reserved

## Table of Contents

1. Introduction, Features and Applications .....	1
Introduction .....	1
Features .....	1
Applications .....	2
2. Specifications .....	2
Electrical Specifications .....	2
Mechanical Specifications.....	2
Elimination of Heat .....	3
Operating Environment and other Specifications.....	3
3. Pin Assignment and Description .....	3
Connector P1 Configurations .....	3
Selecting Active Pulse Edge and Control Signal Mode .....	4
Connector P2 Configurations .....	4
4. Control Signal Connector (P1) Interface.....	4
5. Connecting the Motor.....	5
Connections to 4-lead Motors .....	5
Connections to 6-lead Motors .....	6
Half Coil Configurations .....	6
Full Coil Configurations.....	6
Connections to 8-lead Motors .....	7
Series Connections .....	7
Parallel Connections.....	7
6. Power Supply Selection .....	7
Regulated or Unregulated Power Supply .....	8
Multiple Drives .....	8
Selecting Supply Voltage.....	8
7. Selecting Microstep Resolution and Drive Output Current.....	8
Microstep Resolution Selection .....	9
Current Settings.....	9

Dynamic current setting .....	10
Standstill current setting.....	10
Auto configuration by SW4 .....	10
Set active edge.....	11
8. Select configuration for different motor.....	11
9. Wiring Notes .....	11
10. Typical Connection.....	12
11. Sequence Chart of Control Signals.....	12
12. Protection Functions.....	13
Over-current Protection .....	13
Over-voltage Protection .....	13
Phase Error Protection.....	13
Sensorless Stall Protection .....	13
Protection Indications.....	14
13. Frequently Asked Questions.....	14
Problem Symptoms and Possible Causes .....	15
14. Professional Tuning Software ProTuner.....	16
Introduction .....	16
Software Installation .....	16
Connections and Testing .....	20
RS232 Interface Connection .....	20
Testing the Stepping System .....	20
Software Introduction.....	21
ProTuner Main Window .....	21
ProTuner Toolbar.....	21
Option.....	22
Com Config Window .....	22
Parameters Configuration Window .....	22
Tuning .....	23
Anti-Resonance Introduction .....	28
Internal Pluser .....	28

Procedure for Achieving Optimum Performance .....	29
Err_check .....	30
About.....	31
APPENDIX .....	32
Twelve Month Limited Warranty .....	32
Exclusions .....	32
Obtaining Warranty Service .....	32
Warranty Limitations.....	32
Contact Us.....	34

## 1. Introduction, Features and Applications

### Introduction

The AM882 is a versatility fully digital stepping drive based on a DSP with advanced control algorithm. The AM882 is the next generation of digital stepping motor controls. It brings a unique level of system smoothness, providing optimum torque and nulls mid-range instability. Motor self-test and parameter auto-setup technology offers optimum responses with different motors and easy-to-use. The driven motors can run with much smaller noise, lower heating, smoother movement than most of the drives in the markets. Its unique features make the AM882 an ideal solution for applications that require low-speed smoothness.

The AM882 builds the **\*sensorless stall detection** function to eliminate the cost of feedback device and cabling. Apart from the auto configuration, it has extra 16 selectable built-in auto-configuration parameters which are best match to Leadshine stepping motors.

\*Note: At present the AM882 only detect motor stall when running speed >300RPM.

### Features

- l **Sensorless stall detection, eliminates cost of feedback device and cabling(>300RPM)**
- l Anti-Resonance, provides optimum torque and nulls mid-range instability
- l Motor auto-identification and parameter auto-configuration technology, offers optimum responses with different motors
- l Built-in auto-configuration parameters for 16 Leadshine stepping motor
- l Multi-Stepping allows a low resolution step input to produce a higher microstep output for smooth system performance
- l Microstep resolutions programmable, from full-step to 102,400 steps/rev
- l Supply voltage up to +80 VDC, Output current programmable, from 0.1A to 8.2A
- l Pulse input frequency up to 200 KHz
- l TTL compatible and optically isolated input
- l Automatic idle-current reduction and software configured reduction rate
- l Suitable for 2-phase and 4-phase motors
- l Support PULSE/DIRECTION and CW/CCW modes
- l Over-voltage, over-current, phase-error protections

## Applications

Suitable for a wide range of stepping motors, from NEMA frame size 17 to 34. It can be used in various kinds of machines, such as laser cutters, laser markers, high precision X-Y tables, labeling machines, and so on. Its unique features make the AM882 an ideal solution for applications that require both low-speed smoothness and high speed performances.

## 2. Specifications

### Electrical Specifications (T<sub>j</sub> = 25°C/77°F)

Parameters	Min	Typical	Max	Unit
	Output current	0.1	-	8.2 (5.86 RMS)
Supply voltage	+20	+68	+80	VDC
Logic signal current	7	10	16	mA
Pulse input frequency	0	-	200	kHz
Isolation resistance	500			MΩ

### Mechanical Specifications (unit: mm [inch])

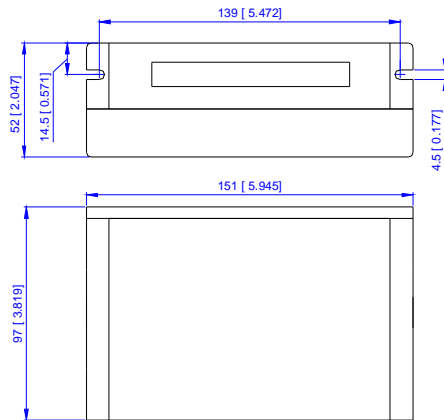

Figure 1: Mechanical specifications

## Elimination of Heat

- Drive's reliable working temperature should be <70°C(158°F), and motor working temperature should be <80°C(176°F);
- It is recommended to use automatic idle-current mode, namely current automatically reduce to 60% when motor stops, so as to reduce drive heating and motor heating;
- It is recommended to mount the drive vertically to maximize heat sink area. Use forced cooling method to cool the system if necessary.

## Operating Environment and other Specifications

Cooling	Natural Cooling or Forced cooling	
Operating Environment	Environment	Avoid dust, oil fog and corrosive gases
	Ambient Temperature	0°C — 50°C (32°F — 122°F)
	Humidity	40%RH — 90%RH
	Operating Temperature	70°C (158°F) Max
	Vibration	5.9m/s <sup>2</sup> Max
Storage Temperature	-20°C — 65°C (-4°F — 149°F)	
Weight	Approx. 570g (20oz)	

## 3. Pin Assignment and Description

The AM882 has two connectors, connector P1 for control signals connections, and connector P2 for power and motor connections. The following tables are brief descriptions of the two connectors. More detailed descriptions of the pins and related issues are presented in section 4, 5, 9.

### Connector P1 Configurations

Pin Function	Details
PUL +	<p><u>Pulse signal</u>: In single pulse (pulse/direction) mode, this input represents pulse signal, each rising or falling edge active (DIP switch configurable); 4-5V when PUL-HIGH, 0-0.5V when PUL-LOW. In double pulse mode (pulse/pulse) , this input represents clockwise (CW) pulse, active both at high level and low level. For reliable response, pulse width should be longer than 2.5μs. Series connect resistors for current-limiting when +12V or +24V used. The same as DIR and ENA signals.</p>
PUL-	

<b>DIR+</b>	<u>Direction signal:</u> In single-pulse mode, this signal has low/high voltage levels, representing two directions of motor rotation; in double-pulse mode (software configurable), this signal is counter-clock (CCW) pulse, active both at high level and low level. For reliable motion response, DIR signal should be ahead of PUL signal by 5μs at least. 4-5V when DIR-HIGH, 0-0.5V when DIR-LOW. Please note that rotation direction is also related to motor-driver wiring match.
<b>DIR-</b>	Exchanging the connection of two wires for a coil to the driver will reverse motion direction.
<b>ALM+</b>	<u>Alarm signal:</u> OC output signal, activated when over-voltage, over current, under-voltage, phase-error and stall-error protection. Output polarity can be programmable. 30V@100mA.
<b>ALM-</b>	
<b>ENA+</b>	<u>Enable signal:</u> This signal is used for enabling/disabling the driver. High level (NPN control signal, PNP and Differential control signals are on the contrary, namely Low level for enabling.) for enabling the driver and low level for disabling the driver. Usually left <b>UNCONNECTED (ENABLED)</b> .
<b>ENA-</b>	

### Selecting Active Pulse Edge and Control Signal Mode

The AM882 supports PULSE/DIRECTION and CW/CCW modes and pulse actives at rising or falling edge. See more information about these settings in Section 13. Default setting is PULSE/DIRECTION mode and rising edge active (NPN, and PNP control signal is on the contrary).

### Connector P2 Configurations

Pin Function	Details
+Vdc	Power supply, 24~80 VDC, Including voltage fluctuation and EMF voltage.
GND	Power Ground.
A+, A-	Motor Phase A
B+, B-	Motor Phase B

### 4. Control Signal Connector (P1) Interface

The AM882 can accept differential and single-ended inputs (including open-collector and PNP output). The AM882 has 3 optically isolated logic inputs which are located on connector P1 to accept line drive control signals. These inputs are isolated to minimize or eliminate electrical noises coupled

onto the drive control signals. Recommend use line drive control signals to increase noise immunity of the drive in interference environments. There is also an optically isolated OC (open collector) output for the alarm signal in P1. In the following figures, connections to open-collector and PNP signals are illustrated.

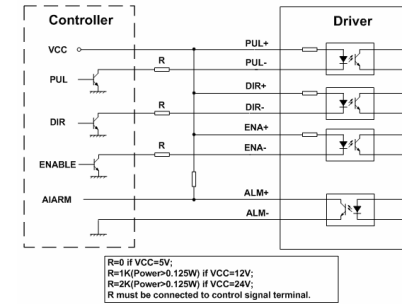

Figure 2: Connections to open-collector signal (common-anode)

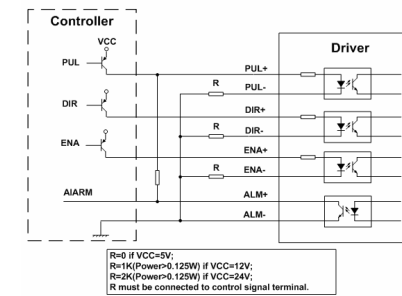

Figure 3: Connection to PNP signal (common-cathode)

## 5. Connecting the Motor

The AM882 can drive any 2-phase and 4-phase hybrid stepping motors.

### Connections to 4-lead Motors

4 lead motors are the least flexible but easiest to wire. Speed and torque will depend on winding inductance. In setting the drive output current, multiply the specified phase current by 1.4 to determine the peak output current.

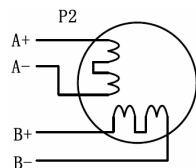

Figure 4: 4-lead Motor Connections

### Connections to 6-lead Motors

Like 8 lead stepping motors, 6 lead motors have two configurations available for high speed or high torque operation. The higher speed configuration, or half coil, is so described because it uses one half of the motor's inductor windings. The higher torque configuration, or full coil, uses the full windings of the phases.

#### Half Coil Configurations

As previously stated, the half coil configuration uses 50% of the motor phase windings. This gives lower inductance, hence, lower torque output. Like the parallel connection of 8 lead motor, the torque output will be more stable at higher speeds. This configuration is also referred to as half chopper. In setting the drive output current multiply the specified per phase (or unipolar) current rating by 1.4 to determine the peak output current.

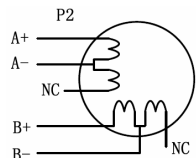

Figure 5: 6-lead motor half coil (higher speed) connections

#### Full Coil Configurations

The full coil configuration on a six lead motor should be used in applications where higher torque at lower speeds is desired. This configuration is also referred to as full copper. In full coil mode, the motors should be run at only 70% of their rated current to prevent over heating.

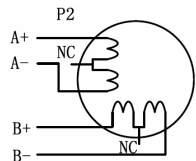

Figure 6: 6-lead motor full coil (higher torque) connections

### Connections to 8-lead Motors

8 lead motors offer a high degree of flexibility to the system designer in that they may be connected in series or parallel, thus satisfying a wide range of applications.

#### Series Connections

A series motor configuration would typically be used in applications where a higher torque at lower speeds is required. Because this configuration has the most inductance, the performance will start to degrade at higher speeds. In series mode, the motors should also be run at only 70% of their rated current to prevent over heating.

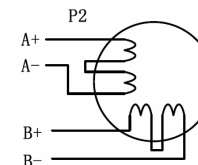

Figure 7: 8-lead motor series connections

#### Parallel Connections

An 8 lead motor in a parallel configuration offers a more stable, but lower torque at lower speeds. But because of the lower inductance, there will be higher torque at higher speeds. Multiply the per phase (or unipolar) current rating by 1.96, or the bipolar current rating by 1.4, to determine the peak output current.

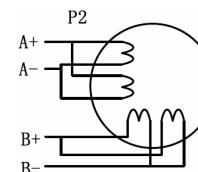

Figure 8: 8-lead motor parallel connections

**NEVER** disconnect or connect the motor while the power source is energized.

### 6. Power Supply Selection

The AM882 can match medium and small size stepping motors (from NEMA frame size 14 to 34) made by Leadshine or other motor manufactures around the world. To achieve good driving performances, it is important to select supply voltage and output current properly. Generally speaking, supply voltage determines the high speed performance of the motor, while output current determines

the output torque of the driven motor (particularly at lower speed). Higher supply voltage will allow higher motor speed to be achieved, at the price of more noise and heating. If the motion speed requirement is low, it's better to use lower supply voltage to decrease noise, heating and improve reliability.

### Regulated or Unregulated Power Supply

Both regulated and unregulated power supplies can be used to supply the drive. However, unregulated power supplies are preferred due to their ability to withstand current surge. If regulated power supplies (such as most switching supplies.) are indeed used, it is important to have large current output rating to avoid problems like current clamp, for example using 4A supply for 3A motor-drive operation. On the other hand, if unregulated supply is used, one may use a power supply of lower current rating than that of motor (typically 50% ~70% of motor current). The reason is that the drive draws current from the power supply capacitor of the unregulated supply only during the ON duration of the PWM cycle, but not during the OFF duration. Therefore, the average current withdrawn from power supply is considerably less than motor current. For example, two 3A motors can be well supplied by one power supply of 4A rating.

### Multiple Drives

It is recommended to have multiple drives to share one power supply to reduce cost, if the supply has enough capacity. To avoid cross interference, **DO NOT** daisy-chain the power supply input pins of the drives. Instead, please connect them to power supply separately.

### Selecting Supply Voltage

The power MOSFETS inside the AM882 can actually operate within +20 ~ +80VDC, including power input fluctuation and back EMF voltage generated by motor coils during motor shaft deceleration. Higher supply voltage can increase motor torque at higher speeds, thus helpful for avoiding losing steps. However, higher voltage may cause bigger motor vibration at lower speed, and it may also cause over-voltage protection or even drive damage. Therefore, it is suggested to choose only sufficiently high supply voltage for intended applications, and it is suggested to use power supplies with theoretical output voltage of +20 ~ +72VDC, leaving room for power fluctuation and back-EMF.

## 7. Selecting Microstep Resolution and Drive Output Current

Microstep resolutions and output current are programmable, the former can be set from full-step to

102,400 steps/rev and the latter can be set from 0.5A to 8.2A. See more information about **Microstep and Output Current Setting** in Section 14.

However, when it's not in software configured mode, this drive uses an 8-bit DIP switch to set microstep resolution, and motor operating current, standstill current and pulse active edge as shown in the following figure:

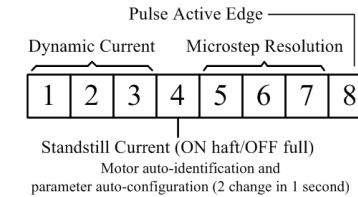

### Microstep Resolution Selection

Microstep resolution is set by SW5, 6, 7 of the DIP switch as shown in the following table:

Microstep	Steps/rev.(for 1.8°motor)	SW5	SW6	SW7
1 to 512	Default/Software configured	ON	ON	ON
2	400	OFF	ON	ON
4	800	ON	OFF	ON
8	1600	OFF	OFF	ON
16	3200	ON	ON	OFF
32	6400	OFF	ON	OFF
64	12800	ON	OFF	OFF
128	25600	OFF	OFF	OFF

### Current Settings

For a given motor, higher drive current will make the motor to output more torque, but at the same time causes more heating in the motor and drive. Therefore, output current is generally set to be such that the motor will not overheat for long time operation. Since parallel and serial connections of motor coils will significantly change resulting inductance and resistance, it is therefore important to set drive output current depending on motor phase current, motor leads and connection methods. Phase current rating supplied by motor manufacturer is important in selecting drive current, however

the selection also depends on leads and connections.

When it's not in software configured mode, the first three bits (SW1, 2, 3) of the DIP switch are used to set the dynamic current. Select a setting closest to your motor's required current.

### Dynamic current setting

Peak Current	RMS Current	SW1	SW2	SW3
Default/Software configured (0.1 to 8.2A)		ON	ON	ON
2.7A	1.93A	OFF	ON	ON
3.6A	2.57A	ON	OFF	ON
4.6A	3.29A	OFF	OFF	ON
5.5A	3.93A	ON	ON	OFF
6.4A	4.57A	OFF	ON	OFF
7.3A	5.21A	ON	OFF	OFF
8.2A	5.86A	OFF	OFF	OFF

**Notes:** Due to motor inductance, the actual current in the coil may be smaller than the dynamic current setting, particularly under high speed condition.

### Standstill current setting

SW4 is used for this purpose. OFF meaning that the standstill current is software configured, and ON meaning that standstill current is set to be the same as the selected dynamic current.

By default, the current automatically reduced to 60% of the selected dynamic current two second after the last pulse. Theoretically, this will reduce motor heating to 36% (due to  $P=I^2 \cdot R$ ) of the original value. **Reduction rate and idle time can be configured in the PC software ProTuner.** See more information in section 13.

### Auto configuration by SW4

Change SW4 two times in one second to identify the motor parameter after power-up if it is the first time installation. Please note that the rotation switch position must be 0 when using this function.

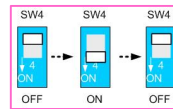

### Set active edge

SW8 is used to set the active edge of the input pulse command signal. The driver will make motor shaft would move one micro step when receive one active pulse edge.

SW8	Active Edge	SW8	Active Edge
ON	Up-rising	OFF	Following

### 8. Select configuration for different motor

There is a rotation switch to select the built-in configuration parameters for different motor. User can select the corresponding parameter according the motor part number. When it is 0, user can tune the parameters in the configuration software or just activate the auto-configuration by SW4.

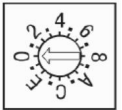

Motor	Switch Position	Motor	Switch Position
Default	0	Reserved	8
57HS09	1	Reserved	9
57HS13	2	Reserved	A
57SH22	3	Reserved	B
86HS35	4	Reserved	C
86HS38	5	Reserved	D
86HS45	6	Reserved	E
86HS85	7	Reserved	F

### 9. Wiring Notes

- In order to improve anti-interference performance of the drive, it is recommended to use twisted pair shield cable.
- To prevent noise incurred in PULSE/DIRECTION signal, pulse/direction signal wires and motor wires should not be tied up together. It is better to separate them by at least 10 cm, otherwise the disturbing signals generated by motor will easily disturb pulse direction signals, causing motor position error, system instability and other failures.
- If a power supply serves several drives, separately connecting the drives is recommended instead of daisy-chaining.



It is prohibited to pull and plug connector P2 while the drive is powered ON, because there is high current flowing through motor coils (even when motor is at standstill). Pulling or plugging connector P2 with power on will cause extremely high back-EMF voltage surge, which may damage the drive.

### 10. Typical Connection

A complete stepping system should include stepping motor, stepping drive, power supply and controller (pulse generator). A typical connection is shown as figure 9.

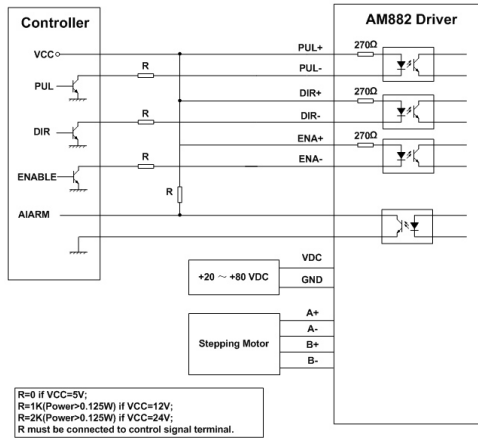

Figure 9: Typical connection

### 11. Sequence Chart of Control Signals

In order to avoid some fault operations and deviations, PUL, DIR and ENA should abide by some rules, shown as following diagram:

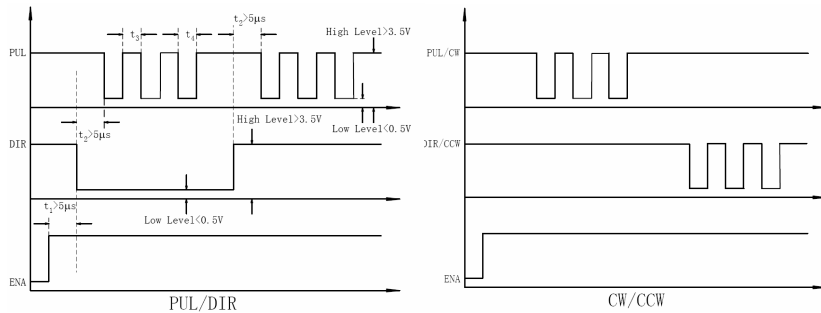

Figure 10: Sequence chart of control signals

### Remark:

- a) t1: ENA must be ahead of DIR by at least 5μs. Usually, ENA+ and ENA- are NC (not connected). See “Connector P1 Configurations” for more information.
- b) t2: DIR must be ahead of PUL active edge by 5μs to ensure correct direction;
- c) t3: Pulse width not less than 2.5μs;
- d) t4: Low level width not less than 2.5μs.

### 12. Protection Functions

To improve reliability, the drive incorporates some built-in protection functions. The AM882 uses one RED LED to indicate what protection has been activated. The periodic time of RED is 5 s (seconds), and how many times the RED turns on indicates what protection has been activated. Because only one protection can be displayed by RED LED, so the drive will decide what error to display according to their priorities. See the following **Protection Indications** table for displaying priorities.

#### Over-current Protection

Over-current protection will be activated when continuous current exceeds the limit or in case of short circuit between motor coils or between motor coil and ground, and RED LED will turn on once within each periodic time (5 s).

#### Over-voltage Protection

When power supply voltage exceeds 90±1 VDC, protection will be activated and RED LED will turn on twice within each periodic time (5 s).

#### Phase Error Protection

Motor power lines wrong & not connected will activate this protection. RED LED will turn on four times within each periodic time (5 s).



#### Sensorless Stall Protection

The AM882 can detect the motor stall status using if motor shaft speed is above 300RPM. When the detection is active, RED LED will blink five times within each periodic time (5s).

**Attention:** When above protections are active, the motor shaft will be free or the LED will blink.

Reset the drive by repowering it to make it function properly after removing above problems. Since there is no protection against power leads (+, -) reversal, it is critical to make sure that power supply leads correctly connected to drive. Otherwise, the drive will be damaged instantly.

**Protection Indications**

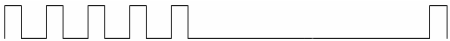
Priority	Time(s) of ON	Sequence wave of RED LED	Description
1 <sup>st</sup>	1		Over-current protection
2 <sup>nd</sup>	2		Over-voltage protection
3 <sup>rd</sup>	4		Phase error protection
4 <sup>th</sup>	5		Sensorless stall detection

**13. Frequently Asked Questions**

In the event that your drive doesn't operate properly, the first step is to identify whether the problem is electrical or mechanical in nature. The next step is to isolate the system component that is causing the problem. As part of this process you may have to disconnect the individual components that make up your system and verify that they operate independently. It is important to document each step in the troubleshooting process. You may need this documentation to refer back to at a later date, and these details will greatly assist our Technical Support staff in determining the problem should you need assistance.

Many of the problems that affect motion control systems can be traced to electrical noise, controller software errors, or mistake in wiring.

**Problem Symptoms and Possible Causes**

Symptoms	Possible Problems
<b>Motor is not rotating</b>	No power
	Microstep resolution setting is wrong
	DIP switch current setting is wrong
	Fault condition exists
<b>Motor rotates in the wrong direction</b>	The drive is disabled
	Motor phases may be connected in reverse
<b>The drive in fault</b>	DIP switch current setting is wrong
	Something wrong with motor coil
<b>Erratic motor motion</b>	Control signal is too weak
	Control signal is interfered
	Wrong motor connection
	Something wrong with motor coil
<b>Motor stalls during acceleration</b>	Current setting is too small, losing steps
	Current setting is too small
	Motor is undersized for the application
	Acceleration is set too high
<b>Excessive motor and drive heating</b>	Power supply voltage too low
	Inadequate heat sinking / cooling
	Automatic current reduction function not being utilized
	Current is set too high

## 14. Professional Tuning Software ProTuner

### Introduction

This section will provide an overview of connection and basic setup instructions for Leadshine’s digital stepping drive AM882 using the **ProTuner** software. These instructions will walk you through the following steps necessary to start up your drive and motor. This section is intended for setting up the drive with the **ProTuner**.

### Software Installation

The **ProTuner** is windows based setup software for tuning Leadshine’s digital stepper drive AM882. It can run in windows systems, including Win95/Win98/WindowsNT/ Windows 2000/Windows XP. And the selected PC should have 1 serial port at least for communicating with the drive.

Double click “**ProTuner\_AM882\_Setup\_V2.0.exe**” to begin installing the **ProTuner**. See Figure 11. Click **Next** to enter the “License Agreement” window. See Figure 12.

Note: The user can get the software from either Leadshine CD or website. Please get the latest version from <http://www.leadshine.com>.



Figure 11: Begin to install the ProTuner

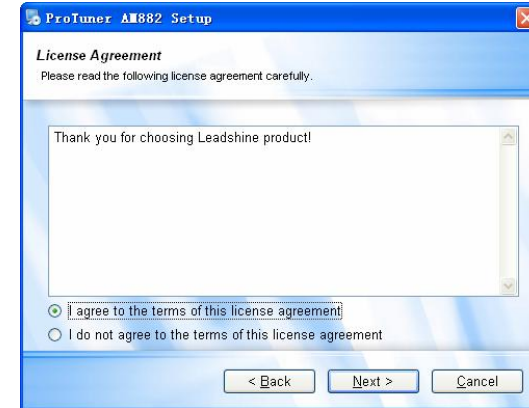

Figure 12: License agreement

Choose “I agree to the terms of this license agreement” and click **Next** to continue installation. The user can enter user’s information in the following window. See Figure 13. After entering the user’s information, click **Next** to select installation folder, where you would like to install the **ProTuner**. See Figure 14.

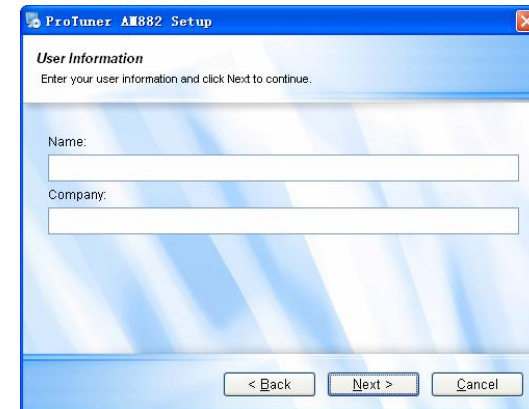

Figure 13: User’s information settings

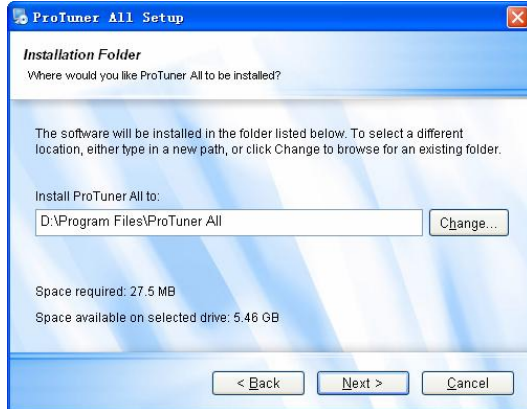

Figure 14: Installation folder settings

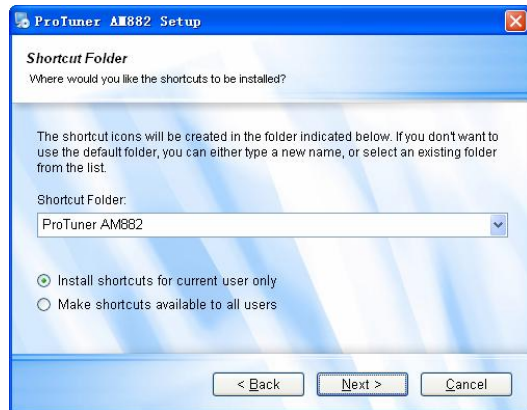

Figure 15: Shortcut folder setting

Set the “Shortcut Folder” in Figure 15 and continue to install the **ProTuner** by following Figure 16 and Figure 17. An **Installation Successful** window will appear if the **ProTuner** is installed successfully. See Figure 18.



Figure 16: Installation information summarization

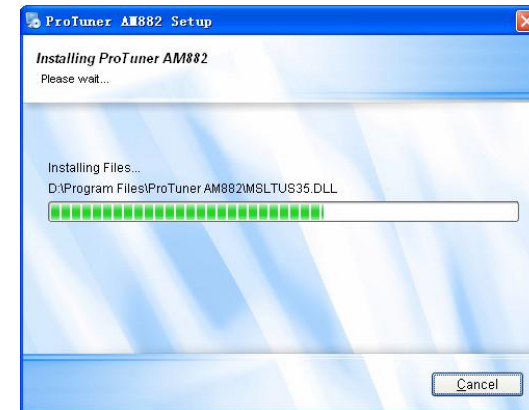

Figure 17: Installing the ProTuner



Figure 18: Finish installation

### Connections and Testing

Connect the stepping system according to the contents in previous sections and connect the PC to the drive as the following figure.

### RS232 Interface Connection

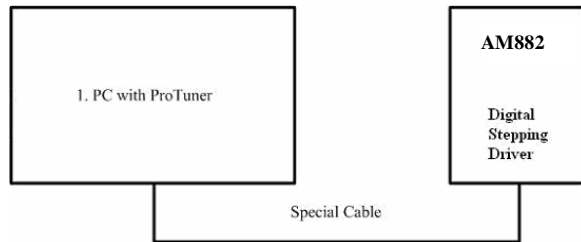

Figure 19: RS232 interface connection

### Testing the Stepping System

Turn on the power supply, the green (Power) LED will light and blink. The AM882 has default parameters stored in the drive. If the system has no hardware and wirings problem, the motor should be locked and the drive should be ready.

If the red LED immediately turns on (flickers), then check power supply, the motor, motor wirings

and try again. Open the tuning software **ProTuner** and check drive status by clicking **Err\_check**. If it's **Phase Error**, check the motor, motor wirings and try again. If it still doesn't work after you followed all of the previous steps, please contact us at [tech@leadshine.com](mailto:tech@leadshine.com).

If the RED LED is OFF and the motor is normal, then you can start to tune the servo with **ProTuner**. However, we recommend you see the following contents before starting tuning.

### Software Introduction

#### ProTuner Main Window

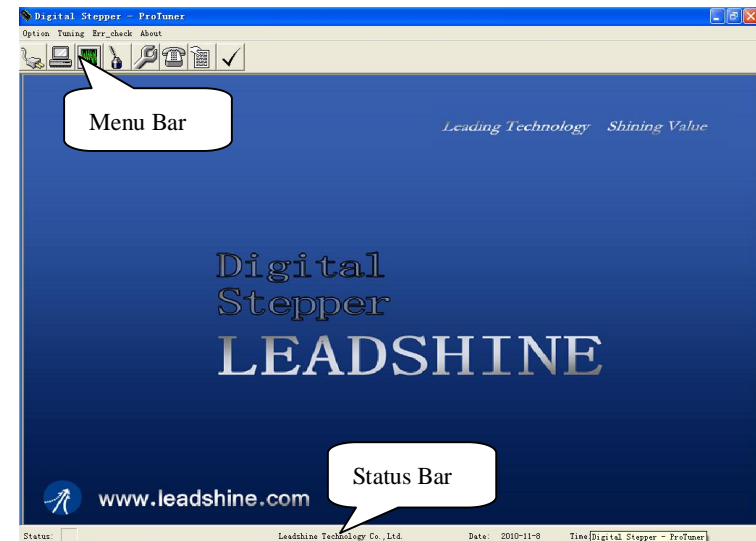
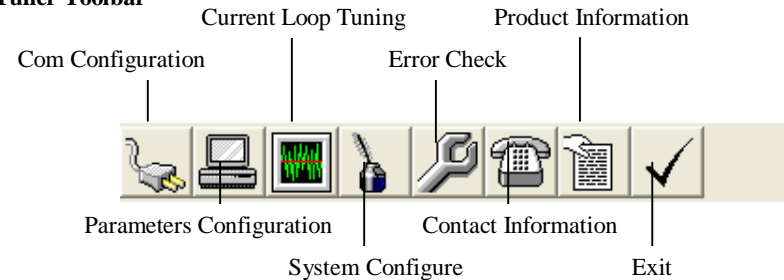

Figure 20: ProTuner

#### ProTuner Toolbar



**Option**

The user can choose three drop-down menus by clicking “**Option**”, including **Com Configuration**, **Parameters Configuration**, and **Exit**.

- I **Com Configuration:** Configure Com communication interface.
- I **Parameteres Configuration:** Read/write parameters between the drive and the ProTuner, or save configuration as a file and load configuration from a file.
- I **Exit:** Exit the **ProTuner**.

**Com Config Window**



Figure 21: RS232 communication configuration window

**Serial Port:** Select the serial communication port to which the drive is connected. The factory default setting is COM1.

**Baud Rate:** Select the communication baud rate. The factory default setting is 38400.

Click **Open** button to establish a connection with the specified settings. When connecting, you can read stored parameter setting from the drive to the ProTuner, or write new parameter setting from the ProTuner to the drive settings in the **parameters configuration** window.

**Parameters Configuration Window**

Recommend to always keep this window active. In this window, the user can read the parameter setting from the drive, or write parameters setting to the drive after finishing to configure all the settings. In addition, the user can also save the configuration to a file for later use or load a

configuration from a stored file. See figure 22.

**Read RAM:** Read parameter settings from the drive’s RAM to the ProTuner.

**Write RAM:** Write parameter settings from the ProTuner to the drive’s RAM.

**Write EEprom:** Write parameter settings from the ProTuner to the drive’s EEprom.

**Reset Drive:** Reset all parameter to default value.

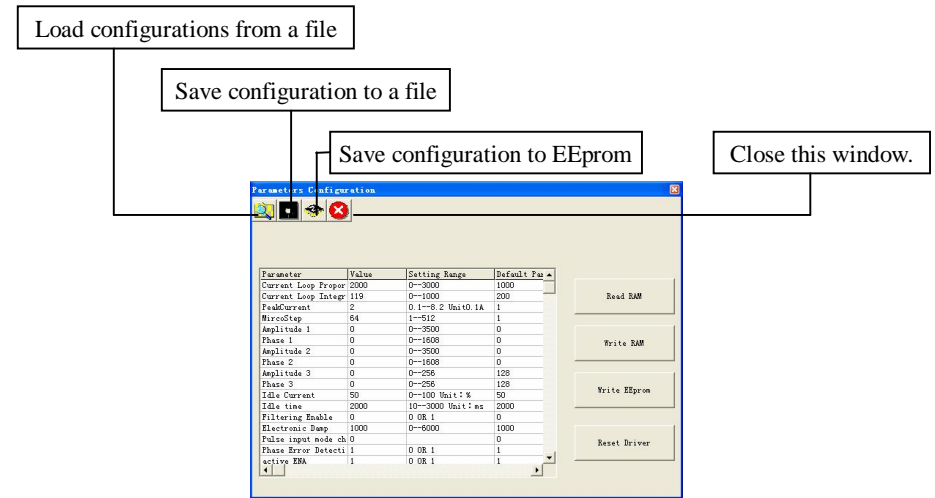

Figure 22: Parameters configuration window

**Tuning**

The user can choose one or two drop-down menu(s) by clicking **Tuning**, including **CurrentLoop** and **SystemConfig**.

- I **CurrentLoop:** In Current Tuning window, the user can tune the **Kp (Proportional Gain)** and **Ki (Integral Gain)** of drive’s current loop to optimize responses with different motors. Start/Restart a Step Response test to get an optimum response.

**Kp: Proportional Gain.** Proportional Gain determines the response of the drive to current setting command. Low Proportional Gain provides a stable system (doesn’t oscillate), has low stiffness, and

large current error, causing poor performances in tracking current setting command in each step like Figure 23. Too large Proportional Gain values will cause oscillations and unstable systems.



Figure 23: Current Tuning window

**Ki: Integral Gain.** Integral Gain helps the drive to overcome static current errors. A low or zero value for the Integral Gain may have current errors at rest. Increasing the Integral Gain can reduce the error. If the Integral Gain is too large, the systems may “hunt” (oscillate) about the desired position.

**Start** button: The user can start a Step Response test by clicking this button. Start/Restart a Step Response test to get an optimum response like Figure 23, and remember to save the settings to the drive by clicking **Write EEprom** in **parameters configuration** window when finish tuning .

**Auto** button: Click this button to auto-configure Kp and Ki for the connected motor. It has the same effect as changing SW4 two times in one second.

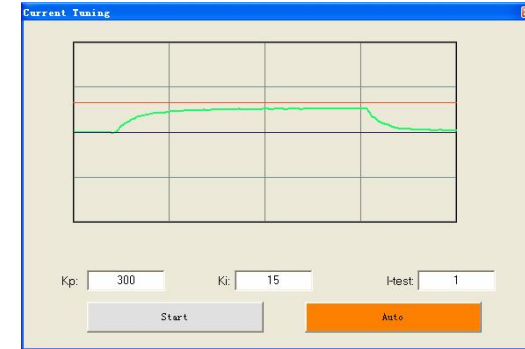

Figure 24: Kp=300, Ki=15 (poor performances)

**Notes:**

However, if the user does not want to tune the current loop after changing a different stepping motor, then **Motor self-test and parameter auto-setup** technology of the AM882 can replace manual tuning the drive with **ProTuner**. Just changes SW4 two times in 1 second (without ProTuner), or click **Auto** button, and then the drive will auto-identify the new motor and auto-configure related control parameters for optimum responses. **Recommend** use this function after changing the driven motor.

**1 SystemConfig:**

In **SystemConfig** window, the user can configure Peak Current, Microstep, Elec Damp, Idle Current, Idle Time, Command Type, Active Edge and eliminate motor resonance. A built-in pulse generator can be used for test during tuning. See Picture 25.

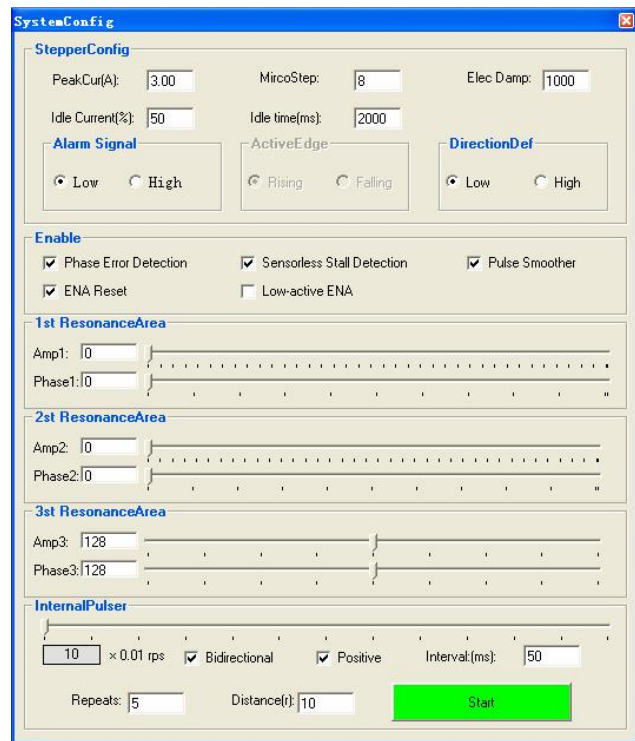

Figure 25: System Configure Window

**PeakCur: Peak Current.** The value is the peak current to the selected motor and can be set from 0.1 to 8.2 A. The user can set the peak current with **ProTuner** or DIP switches, see more information about setting output current of the drive in section 5 “**Connecting the Motor**” and section 7 “**Selecting Microstep Resolution and Drive Output Current**”.

**MicroStep: Microstep Resolution.** The value is drive’s microstep resolution setting and can be set from 1 to 512. The user can set the microstep with **ProTuner** or DIP switches, See more information about setting output current of the drive in section 7 “**Selecting Microstep Resolution and Drive Output Current**”.

**ElecDamp: Electronic Damping Coefficient.** The electronic damping restrains resonance of the system and prevents amplitude of the oscillation from increasing to the extent that it makes the motor

be out of control. The optimal value depends on the system, and the default value is 3000.

**Idle Current: Standstill Current when motor stop.** When the motor stop time exceeds the **Idle Time**, the motor coil current reduces to Idle Current (In percentage). The percentage is rated to the Peak Current.

**Idle Time:** See **Idle Current**.

**Alarm Signal:** Set active level for the alarm signal. High for active high and Low for active low..

**CommandType: Command Type** of control signal, including PULSE/DIRECTION and CW/CCW. Set this parameter according to **Command Type** of motion controller.

**ActiveEdge: Active Edge.** This function is disabled in the software because you can set it by the DIP switch SW8. See chapter 7 for more information.

**DirectionDef: Direction Definition.** Relate the default running direction to a **HIGH** level input in DIR or **Low** level input in DIR. This panel is used for PULSE/DIRECTION command type only. Please note that the default direction is also related to motor coil connections.

**Phase Error Detection:** Select whether the phase error protection is activated when there is a phase error. Check the box to enable the phase error detection, Uncheck the box to disable the phase error detection.

**Sensorless Stall Detection:** Select whether the sensorless stall detection is activated when motor stall. Check the box to enable the sensorless stall detection and uncheck the box to disable the phase error detection.

**Pulse Smoother:** Enable/disable the pulse smoother. A digital filter has been built into the AM822 to eliminate the ripple of the input pulse and smooth the motion. Check the box to enable the pulse smoother and uncheck the box to disable the smoother.

**ENA Reset:** Select whether the ENA signal can be used to reset the driver when the alarm is activated. Check the box to allow ENA reset and uncheck the box to disable it.

**Low-active ENA:** Select active level for ENA (Enable) input.



## Anti-Resonance Introduction

Step motors are highly resonant, which results in vibration and ringing. The ringing utilizes a large fraction of the motor's available torque – thereby wasting performance. Furthermore, at mid-range velocities, the resonance can become so severe that the motor loses synchronization and stalls. The AM882 drive provides robust anti-resonance control to stop the vibrations and maintain equilibrium. This feature requires that the drive be configured with respect to the total inertia in the system. If set improperly, the effectiveness of the feature may be diminished.

The user can invoke or disable the feature by setting **Amp** and **Phase** values in **SystemConfig** window. **Amp** and **Phase** values all zero is to disable the feature, otherwise is to invoke the feature. It should be enabled unless the system configuration either does not need it or cannot tolerate it. A system with loose couplings or viscous loading generally does not need this feature. If a system has compliant (springy) coupling and is absent appreciably viscosity, it may not respond well to the active, anti-resonant loop in the drive. The anti-resonant feature is not designed to damp such a 4<sup>th</sup> order system. If the application of anti-resonance results in degradation or instability, it should be disabled.

**1<sup>st</sup> ResonanceArea: Parameters for 1<sup>st</sup> resonance area.** It is usually between 0.6rps and 1.2rps.

**Amp1** is Amplitude adjustment for 1<sup>st</sup> resonance area.

**Phase1** is Phase adjustment for 1<sup>st</sup> resonance area. The user can enter a value directly in the text box or move the slider bar back and forth to get an optimum value.

**2<sup>nd</sup> ResonanceArea: Parameters for 2<sup>nd</sup> resonance area.** It is usually between 1.2rps and 2.4rps.

Default **Amp2** and **Phase2** values are zero.

**3<sup>rd</sup> ResonanceArea: Parameters for 3<sup>rd</sup> resonance area.** It is usually between 2.4rps and 4.8rps.

Default **Amp3** and **Phase3** values are 128.

## Internal Pluser( Pulse Generator)

The internal pulse generator offers a simple motion control for self-test and anti-resonance tuning. The user can adjust moving velocity, configure the direction and repeats of the motion.

**Bidirectional:** Click the check box to make the motion be bidirectional. Otherwise the motor only run

in one direction.

**Positive:** It is used to change the initial direction for the motion.

**Interval:** Stop time before the next motion repeat. Unit: ms.

**Repeats:** Motion repeat times. If it is bidirectional, one repeat is moving forward then back.

**Distance:** Moving distance in one direction in revolution.

**Start/Stop:** Start/Stop the motion.

### Note:

When you adjust the velocity by moving the slider forth and back, the motor velocity would not change immediately as you expected. That is because the drive only read the new speed when it changes direction. Also be careful about the initial direction and moving distance if the motor is installed on a machine. It is recommended that set low speed and small distance if you are not sure whether the direction and distance is correct or not.

## Procedure for Achieving Optimum Performance

**Step 1:** Start the motion test by clicking **Start/Stop** button. Find a resonance speed by slightly moving the slider bar of internal pulse generator back and forth. You can also use the arrow keys to adjust the speed precisely.

**Step 2:** Run the motor at the resonance speed and verify the motor smoothness. You may find a better smoothing value by slightly moving the slider bars of **AMP(s)** and **Phase(s)** back and forth.

It is very important to make the **AMP(s)** and **Phase(s)** adjustments at the proper test speeds with an unloaded motor. Running at an incorrect test speed will not excite the motor at its peak resonance, making it more difficult to find proper adjustment values. Optimum **AMP(s)** and **Phase(s)** values may be a little different between running the tests with an unloaded motor and a load motor.

For example, we find a resonance speed at 0.98 rps. We begin to move the Amp1 slider forth and the motor vibration and noise became lower and lower. Finally we find the move is the smoothest when **Amp 1** is 1400. The motor vibration and noise increase if **Amp 1** exceeds 1400. Then we follow the same procedure to search the best point for **Phase 1**. See Figure 26. Anti-resonance tuning is done.

Please remember to click **Write EEprom** to write the final parameter settings to the drive when finish tuning.

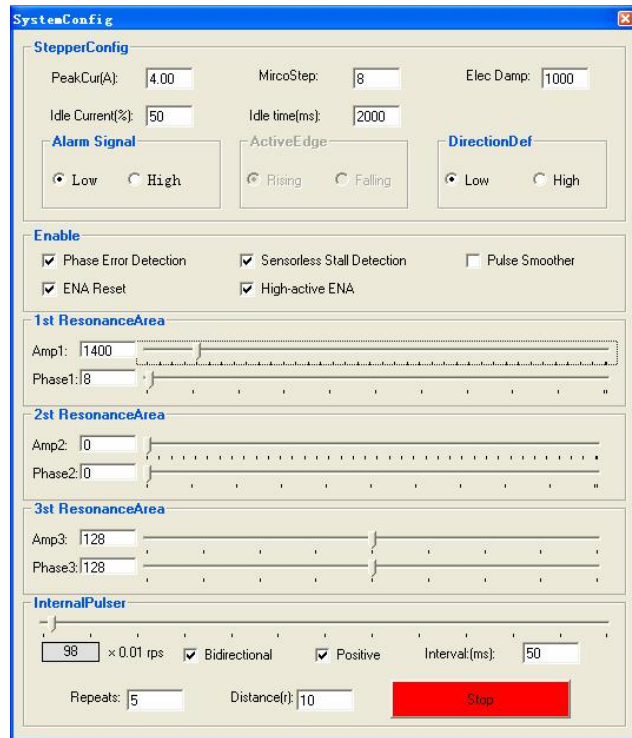

Figure 26: 1<sup>st</sup> Anti -Resonance Tuning (Speed=0.98rps)

**Err\_check**

I **Error Check:** This window shows both the present status of each error event and their history. Current error event(s) can be reset by clicking **Erase Current Err!** button, and all error events can be reset by clicking **Erase All!** button. List of the last ten drive faults. #0 being the most recent, #9 is the oldest. See Figure 27.

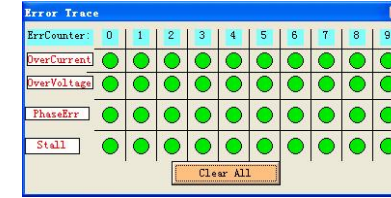

Figure 27: Error check window

**OverCurrent: Over-current Protection.** Protection will be activated when continuous current exceeds the limit.

**OverVoltage: Over-voltage Protection.** When power supply voltage exceeds  $90 \pm 1$  VDC, protection will be activated.

**PhaseErr: Phase Error Protection.** Motor power lines wrong & not connected will activate this protection.

**ErrCounter:** Displays current error(s) and current error history.

**Erase All!: Erase All! button.** The user can clear all error(s) including error history by clicking this button.

**About**

The user can choose two drop-down menus by clicking “About”, including **Product Information** and **Contact Us**.

I **Product Information** window: Shows some product information about ProTuner.

I **Contact Us** window: Shows some contact information about Leadshine.



Figure 28: Product information



Figure 29: Contact information

## APPENDIX

### Twelve Month Limited Warranty

Leadshine Technology Co., Ltd. warrants its products against defects in materials and workmanship for a period of 12 months from shipment out of factory. During the warranty period, Leadshine will either, at its option, repair or replace products which proved to be defective.

### Exclusions

The above warranty does not extend to any product damaged by reasons of improper or inadequate handlings by customer, improper or inadequate customer wirings, unauthorized modification or misuse, or operation beyond the electrical specifications of the product and/or operation beyond environmental specifications for the product.

### Obtaining Warranty Service

To obtain warranty service, a returned material authorization number (RMA) must be obtained from customer service at e-mail: [tech@leadshine.com](mailto:tech@leadshine.com) before returning product for service. Customer shall prepay shipping charges for products returned to Leadshine for warranty service, and Leadshine shall pay for return of products to customer.

### Warranty Limitations

Leadshine makes no other warranty, either expressed or implied, with respect to the product. Leadshine specifically disclaims the implied warranties of merchantability and fitness for a particular purpose. Some jurisdictions do not allow limitations on how long and implied warranty lasts, so the above limitation or exclusion may not apply to you. However, any implied warranty of merchantability or fitness is limited to the 12-month duration of this written warranty.

### Shipping Failed Product

If your product fail during the warranty period, e-mail customer service at [tech@leadshine.com](mailto:tech@leadshine.com) to

obtain a returned material authorization number (RMA) before returning product for service. Please include a written description of the problem along with contact name and address. Send failed product to distributor in your area or: Leadshine Technology Co., Ltd. 3/F, Block 2, Nanyou Tianan Industrial Park, Nanshan Dist, Shenzhen, China. Also enclose information regarding the circumstances prior to product failure.

## Contact Us

### China Headquarters

**Address:** 3/F, Block 2, Nanyou Tianan Industrial Park, Nanshan District Shenzhen, China

**Web:** <http://www.leadshine.com>

### Sales Hot Line:

**Tel:** 86-755-2643 4369 (for All)

86-755-2641-7674 (for Asia, Australia, Africa areas)

86-755-2640-9254 (for Europe, America areas)

**Fax:** 86-755-2640-2718

**Email:** [sales@leadshine.com](mailto:sales@leadshine.com).

### Technical Support:

**Tel:** 86 755-2641-8447 and 86-755-2647-1129

**Fax:** 86-755-2640-2718

**Email:** [tech@leadshine.com](mailto:tech@leadshine.com) and [vic@leadshine.com](mailto:vic@leadshine.com).

### Leadshine U.S.A

**Address:** 25 Mauchly, Suite 318 Irvine, California 92618

**Tel:** 1-949-608-7270

**Fax:** 1-949-608-7298

**Web:** <http://www.leadshineUSA.com>

**Email:** [sales@leadshineUSA.com](mailto:sales@leadshineUSA.com) and [support@leadshineUSA.com](mailto:support@leadshineUSA.com).

### Leadshine Hong Kong

**Address:** Rm 3, 9/F, Block E, Wah Lok Industrial Center, 31-41 Shan Mei St., Fo Tan, Shatin, Hong Kong

**Tel:** 852-2952-9114

**Fax:** 852-2952-9395

**Email:** [hk\\_sales@leadshine.com](mailto:hk_sales@leadshine.com).