

www.optibelt.com
optibelt

Technical Manual

optibelt *OMEGA* Chloroprene Timing Belts

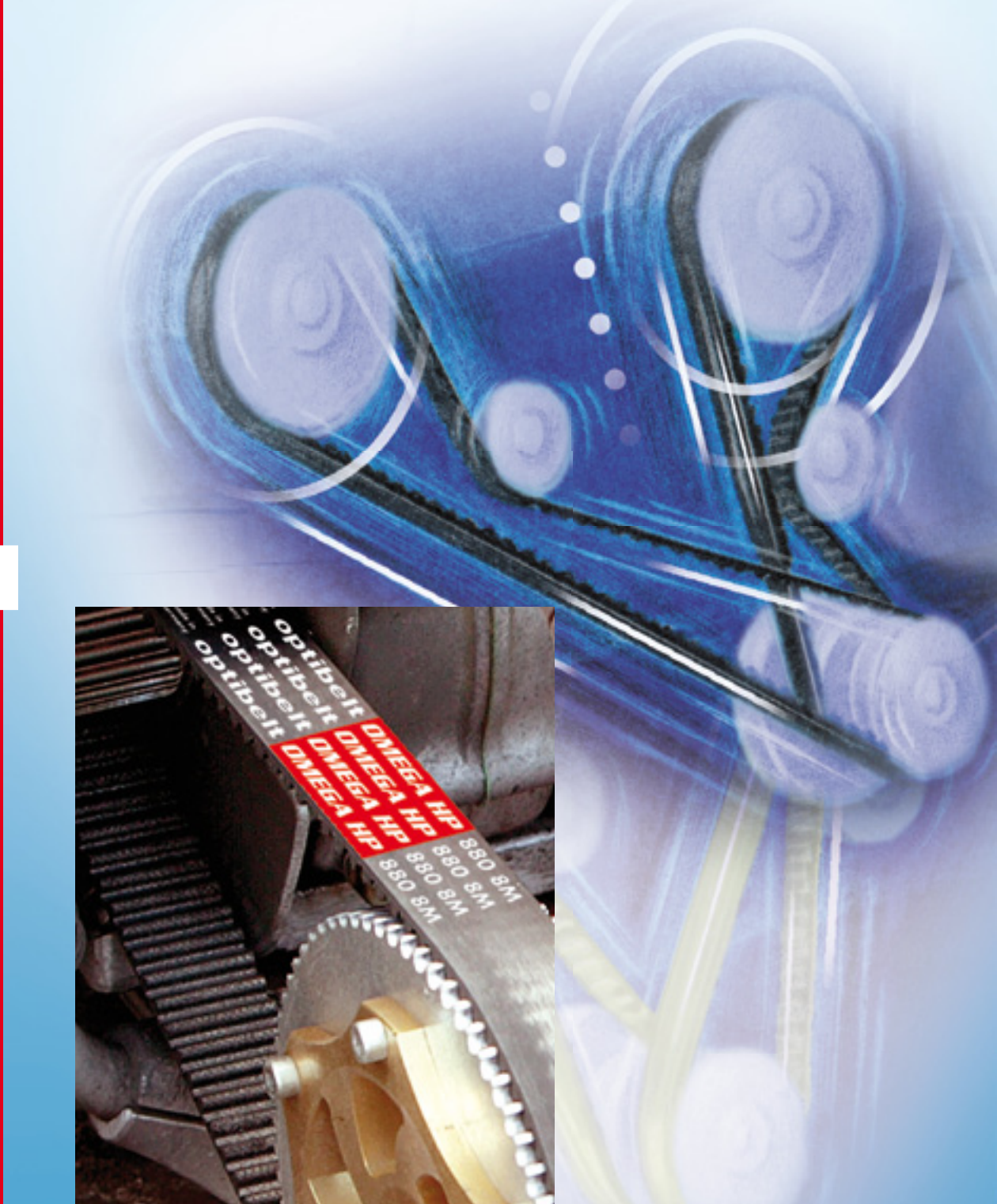

Drive solutions with Optibelt

Technical Manual for Timing Belts with **optibelt OMEGA** Sections



Optibelt OMEGA timing belts have been developed for use in high performance drives. Drive speed is transmitted synchronously, i.e. without speed loss, and with a constant transmission ratio.

The Optibelt OMEGA tooth profile reduces significantly the running noise level. The teeth are formed to ensure that they mesh perfectly and with minimal friction, into the pulley teeth. Optibelt OMEGA timing belts will run in HTD[®] and RPP[®] pulleys.

This technical manual contains all important information for the belts usage. Furthermore, the calculation methods for the drive design with OMEGA, OMEGA HP, OMEGA Fan Power and OMEGA HL timing belts is also presented.

The belt characteristics described may change due to various influences. Thus, the drives must be designed based on their future use (or in a way that comes close to their future use).

If you have any further questions, please make use of the free service offered by our Applications Engineering Department.

Optibelt weltweit





www.optibelt.com



Power Transmission

- | | | | |
|---|--|---|---|
|  | Optibelt GmbH
D-37671 Hötter
www.optibelt.de |  | Optibelt Österreich GmbH
A-1230 Wien
www.optibelt.at |
|  | Optibelt (UK) Ltd.
GB-Warrington WA2 8QY
www.optibelt.co.uk |  | Optibelt Polska Sp. z o.o.
PL-41-303 Dąbrowa Górnicza
www.optibelt.pl |
|  | Optibelt Nederland B.V.
NL-2181 HC Hillegom
www.optibelt.nl |  | ООО „Optibelt Power Transmission“
141800 Dmitrow
www.optibelt.ru |
|  | Optibelt Finland Oy
FI-00750 Helsinki
www.optibelt.fi |  | Optibelt Hungary Kft.
H-6792 Zsombó
www.optibelt.hu |
|  | Optibelt Skandinaviska AB
S-21762 Malmö
www.optibelt.se |  | Optibelt Corporation
Addison, Illinois 60101/USA
www.optibelt.us |
|  | Verkauf Dänemark
<i>Sales Denmark</i>
www.optibelt.dk |  | Optibelt (Canada) Inc.
L3R 4H9 Markham, Ontario/Canada
www.optibelt.ca |
|  | Verkauf Norwegen
<i>Sales Norway</i>
www.optibelt.no |  | Optibelt do Brasil Ltda.
CEP 04715-002 São Paulo-SP/Brasil
www.optibelt-br.com |
|  | Optibelt France SAS
F-68520 Burnhaupt-le-Haut
www.optibelt.fr |  | Optibelt Asia Pacific Pte. Ltd.
Singapore 508708
www.optibelt.sg |
|  | Optibelt AG
CH-4657 Dulliken
www.optibelt.ch |  | Optibelt Power Transmission (Shanghai) Co., Ltd.
Shanghai 201612/P.R. China
www.optibelt.cn |
|  | Optibelt GmbH
B-2160 Wommelgem
www.optibelt.be |  | Optibelt Power Transmission India Pvt. Ltd.
Vishrantwadi, Pune - 411 015
www.optibelt.in |
|  | Optibelt España, S.A.
E-08205 Sabadell
www.optibelt.es |  | Optibelt Australia PTY. LTD.
Dandenong, Victoria 3175
www.optibelt.com.au |
|  | Optibelt AG
I-20025 Legnano (Mi)
www.optibelt.it | | |

Content



Introduction	1
Distribution Organisation of the Arntz Optibelt Group	2

Product Description

Timing Belts with Optibelt OMEGA Sections	6-7
Optibelt OMEGA HL Timing Belts.....	8-9
Optibelt OMEGA HL Timing Belts, Standard Range	10-11
Optibelt OMEGA FanPower Timing Belts.....	12
Optibelt OMEGA FanPower Timing Belts, Standard Range	13
Optibelt OMEGA HP Timing Belts	14-15
Optibelt OMEGA HP Timing Belts, Standard Range	16-19
Optibelt OMEGA Timing Belts	20
Optibelt OMEGA Timing Belts, Standard Range	21-25

Calculation

Explanation of the Symbols	26
Optibelt OMEGA HL Timing Belts, Guidelines for the Selection	27
Optibelt OMEGA HP, Optibelt OMEGA FanPower Timing Belts, Guidelines for the Selection.....	28
Optibelt OMEGA Timing Belts, Guidelines for the Selection.....	29
Service Factors	30
Supplementary Factors.....	31
Formulae and Calculation Example	32-33
Belt Tension	34
Calculation with Optibelt CAP Drive Calculation Programme	35

Content



Power Ratings

Optibelt OMEGA HL Timing Belt, Section and Construction 8M HL	36
Optibelt OMEGA HL Timing Belt, Section and Construction 14M HL	37
Optibelt OMEGA FanPower Timing Belt, Section and Construction 8M FP	38
Optibelt OMEGA FanPower Timing Belt, Section and Construction 14M FP	39
Optibelt OMEGA HP Timing Belt, Section and Construction 3M HP	40
Optibelt OMEGA HP Timing Belt, Section and Construction 5M HP	41
Optibelt OMEGA HP Timing Belt, Section and Construction 8M HP	42
Optibelt OMEGA HP Timing Belt, Section and Construction 14M HP	43
Optibelt OMEGA Timing Belt, Section and Construction 2M	44
Optibelt OMEGA Timing Belt, Section and Construction 3M	45
Optibelt OMEGA Timing Belt, Section and Construction 5M	46
Optibelt OMEGA Timing Belt, Section and Construction 8M	47
Optibelt OMEGA Timing Belt, Section and Construction 14M	48

Dimensions and Tolerances

Timing Belt with Optibelt OMEGA Section	49
Standard Timing Pulleys, Pitch Diameter and Outside Diameter	50-53
Optibelt ZRS HTD® Timing Pulleys for Cylindrical Bore	54-61
Optibelt ZRS HTD® Timing Pulleys for Taper Bushes	62-67
Optibelt TB Taper Bushes	68
Recommended Special Constructions	69
Timing Belt Pulleys, Dimensions and Tolerances	70-71

Design Hints

Flanged Pulleys/Tension Idlers	72
Installation and Maintenance	73
Problems – Causes – Remedies	74
Data Sheet for the Calculation/Checking of Drives with Optibelt OMEGA Timing Belts	75

Product Description

Timing Belts with **optibelt OMEGA** Sections



Power Transmission

Optibelt OMEGA section

The Optibelt OMEGA section is a further development of the Optibelt HTD® section. Its advantage compared to the other timing belt sections is: quieter running.



optibelt OMEGA HL

On high and low speed drives, the Optibelt OMEGA HL timing belt exceeds the performance of the OMEGA HP by up to 15%. It was also specially designed for shock loaded drives.

The OMEGA HL achieves supreme operational reliability combined with optimum economic efficiency when newly designed for these types of application.

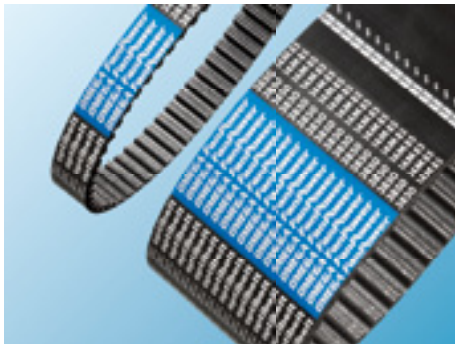

optibelt OMEGA FanPower

The Optibelt OMEGA FanPower timing belt was developed for fan drives in the oil industry.

The Optibelt OMEGA FanPower is characterized by a long service life and antistatic properties.



optibelt OMEGA HP

The Optibelt OMEGA HP timing belt reaches a performance level, up to 100% higher than that of Optibelt OMEGA and is especially suited to cost efficient new designs.

The Optibelt OMEGA HP is suitable for both low speed and high speed drives with high power and steady loads.



optibelt OMEGA

The Optibelt OMEGA timing belt has the performance level of the established Optibelt HTD® timing belt and is its replacement.

The belt is best for medium performance drives in all speed ranges having no heavy shock loading.

Double timing belts for drives with reversible speed can be delivered with HTD® sections. Double timing belts with Optibelt OMEGA sections on request. Power ratings see Optibelt OMEGA page 46 to 48.

optibelt ZRS

Optibelt OMEGA, OMEGA HP, OMEGA FanPower and OMEGA HL timing belts are used in Optibelt ZRS HTD® timing belt pulleys or in RPP® timing belt pulleys. For applications in other pulleys, please contact the Optibelt Applications Engineering Department.

Product Description

Timing Belts with **optibelt OMEGA** Section



All Optibelt OMEGA timing belts have inherent resistance to oil, heat, cold, ozone and tropical conditions. No special labelling is required

Oil resistance

The moderate oil resistance prevents the damaging effects of mineral oils and greases, as long as these materials are not in permanent contact with the timing belt and/or are not present in large quantities. With increased demands for resistance, e.g. to mineral oils, the performance of the Optibelt OMEGA timing belts can be improved by the use of special constructions. Please contact the Optibelt Applications Engineering Department.

Temperature resistance

The timing belt can withstand ambient temperatures from $\approx -30\text{ }^{\circ}\text{C}$ to $+100\text{ }^{\circ}\text{C}$. Temperatures outside this range lead to premature ageing and embrittlement of the timing belts and thus to their premature failure. The temperature resistance of Optibelt OMEGA timing belts can be extended by the use of special constructions, e.g. to $+140\text{ }^{\circ}\text{C}$. Please contact the Optibelt Applications Engineering Department.

Electrical conductivity

Electrical conductivity enables the safe discharge of electrostatic charges. This charging can have such a strong impact on timing belts with insufficient electrical conductivity that there is the danger of ignition due to sparking. The use of electrically conductive timing belts requires that the properties be checked according to ISO 9563. The electrical conductivity is confirmed by the issue of an inspection certificate.

Noise emission

The optimised tooth shape and the indent in the tooth tip on the Optibelt OMEGA promotes a significantly lower noise level. In combination with the newly developed materials, the noise level is further reduced, even at high speeds and with high belt tensions.

Operational life

Belt models with increased capacity can exceed the potential operational life many times over, particularly for highly or overloaded drives with timing belts in technical standard models.

Example: Dynamic tests with Optibelt OMEGA HP show that the running times, compared to standard timing belts, are up to 18 times higher.

Efficiency

The specially developed tooth fabric and the flexible belt design make possible a virtually frictionless drive with an efficiency of up to 98%.

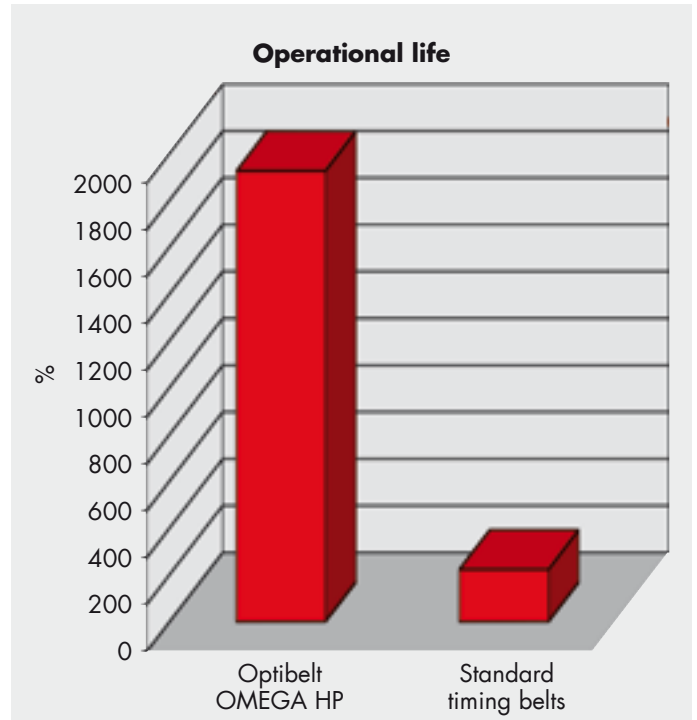

Example of application: roller path

Product Description

Timing Belts with **optibelt OMEGA HL** Section



Power Transmission

Construction

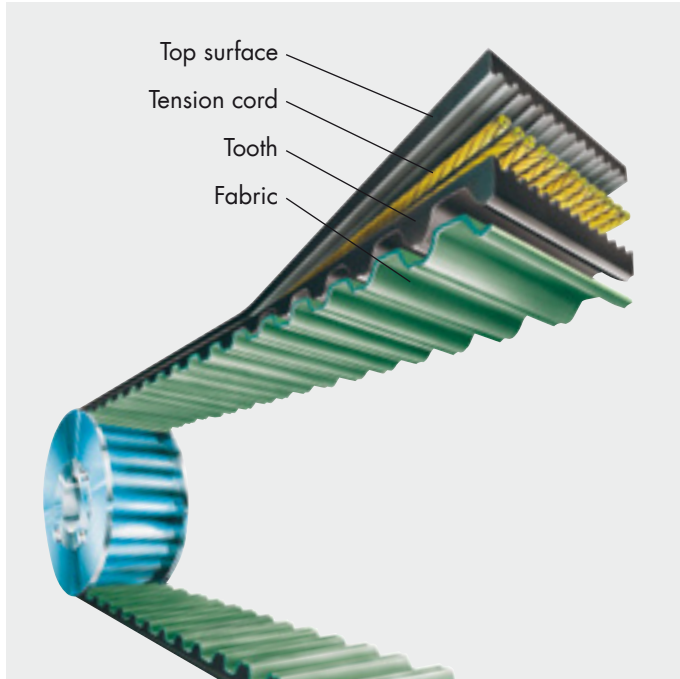

Top surface

The top surface of the OMEGA HL as well as the material of the teeth consists of polychloroprene reinforced with aramid fibres. Thus, an even more abrasion resistant surface is in contact with a reverse bend idler. This surface protects the tension cord from environmental influences.

Tension cord

In contrast to the OMEGA HP with glass cord, the OMEGA HL uses a considerably stronger, reinforced glass cord. Thus, the power can be further increased by up to 25 %; shock resistance also increases considerably.

Teeth

The considerably increased tooth strength (compared to OMEGA) is made possible by the use of aramid fibres in the polychloroprene compound. This material enables a very good tooth shape stability as well as an increased shear strength for every single tooth of the OMEGA HL.

Fabric

The shear strength of the teeth is supported by a solid, extremely tough fabric. The shape of the OMEGA teeth and the minimal friction fabric enable a smooth meshing of the belt tooth into the pulley tooth. In addition, the special polyamide fabric is very wear resistant.

The new high performance timing belt for extremely high loads across the whole speed spectrum

Optibelt has developed this belt in the sections 8M and 14M especially for drives with high torques and severe shock loads. These types of drives can often be found in general engineering.

For this use, the construction and the material of the timing belt have been optimised in such a way that highest operational reliability paired with optimal economic efficiency is reached when newly designing a drive. Initially the belt will be available in the 8M section.

Optibelt OMEGA HL timing belts are used in Optibelt ZRS HTD® pulleys or in RPP® timing belt pulleys. For applications in other pulleys, please contact the Optibelt Applications Engineering Department.

A reinforced glass tension cord is used. This innovative glass cord distinguishes itself by the combination of the following, important characteristics:

- good resistance to shock loading
- very high dynamic resistance
- very low residual and elastic stretch

Therefore, the belt performance can be increased by an additional 15 %, compared to OMEGA HP. In contrast to an aramid cord, which also has a very high resistance to shock loading, the reinforced glass cord has a considerably lower residual stretch during the running time. Aramid cord has a high residual stretch (see diagram) during running. The minimal tension loss of the reinforced glass cord leads to the maintenance of the section and thus to a load which is distributed more evenly on the teeth during running.

In addition, the reinforced glass cord can also be used at medium and high speeds while the use of the aramid cord is limited to low and medium speeds. In contrast to the aramid cord, the reinforced glass cord enables a considerable extension to the range of applications.

Belt tension decay

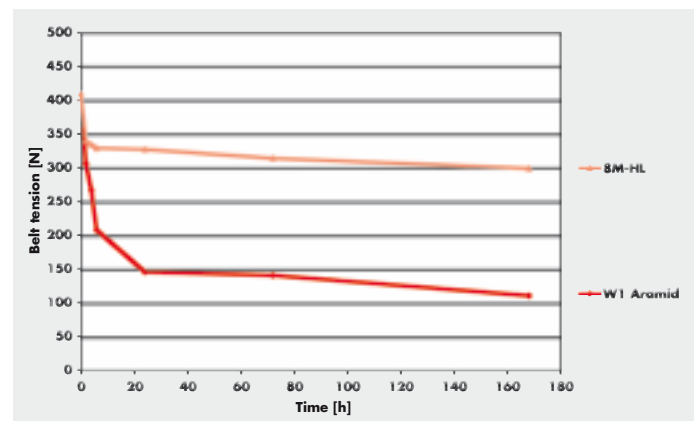

Product Description

Timing Belts with **optibelt OMEGA HL** Sections

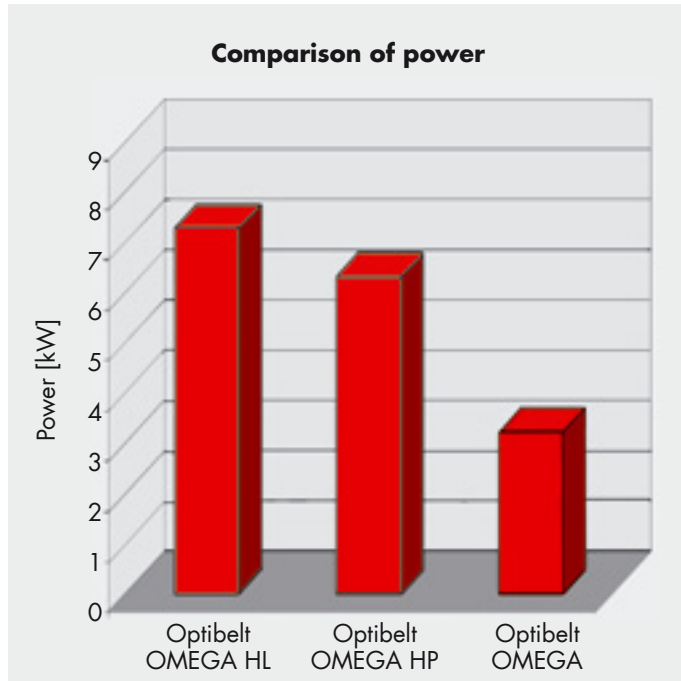

Comparing power ratings

Section and construction	8M HL	8M HP	8M
Pitch [mm]	8	8	8
Width [mm]	20	20	20
Pulley diameter [mm]	96.77	96.77	96.77
Speed [min ⁻¹]	600	600	600
Nominal power [kW]	6.86	5.96	2.82

Preferred areas of application

- Textile machines
- Machine tools
- Compressors
- Printing machines
- Wood working machines
- Paper machines

Overview of the advantages and characteristics of the Optibelt OMEGA HL

- dimensionally stable construction with high flexibility
- very low residual and elastic stretch of the cord
- friction and abrasion resistant, fabric with high shear strength, therefore,
- up to 2.5 times higher power transmission capability (an increase of up to 150%) compared to standard OMEGA timing belts in the standard construction
- approx. up to 15% increase of the power transmission compared to the established high performance construction OMEGA HP
- suitable for low and high speed, high powered drives
- good resistance to medium and high shock loading
- further extended, very large range of applications

Advantages and characteristics of a drive with Optibelt OMEGA HL timing belts in these areas application

- reduced drive volume compared to OMEGA HP and in particular to OMEGA timing belts in standard construction, therefore,
- reduced costs for belts and pulleys
- greater options for drive design
- reduced shaft diameters and smaller bearings
- reduced running noise levels
- improved efficiency

Significant cost reduction for the system and high operational reliability for further improvements in the economic efficiency of the new drives

For additional advantages and characteristics, see Optibelt OMEGA on page 20.

Product Description

optibelt OMEGA HL Timing Belts

Standard Range



Power Transmission

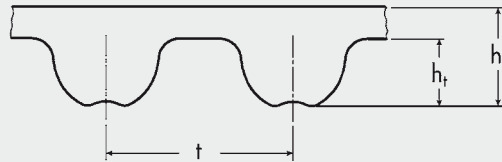

Section	8M HL
t [mm]	8.0
h _s [mm]	5.4
h _t [mm]	3.2

Optibelt OMEGA 8M HL

Belt designation	Pitch length [mm]	Number of teeth	Belt designation	Pitch length [mm]	Number of teeth
288 8M HL•	288.00	36	1160 8M HL•	1160.00	145
352 8M HL	352.00	44	1184 8M HL•	1184.00	148
376 8M HL•	376.00	47	1200 8M HL	1200.00	150
416 8M HL•	416.00	52	1216 8M HL•	1216.00	152
424 8M HL•	424.00	53	1224 8M HL•	1224.00	153
480 8M HL	480.00	60	1248 8M HL•	1248.00	156
512 8M HL•	512.00	64	1256 8M HL•	1256.00	157
520 8M HL•	520.00	65	1264 8M HL•	1264.00	158
560 8M HL	560.00	70	1280 8M HL	1280.00	160
576 8M HL•	576.00	72	1304 8M HL	1304.00	163
600 8M HL	600.00	75	1328 8M HL•	1328.00	166
608 8M HL	608.00	76	1344 8M HL•	1344.00	168
632 8M HL•	632.00	79	1360 8M HL	1360.00	170
640 8M HL	640.00	80	1400 8M HL•	1400.00	175
656 8M HL	656.00	82	1424 8M HL	1424.00	178
680 8M HL•	680.00	85	1440 8M HL	1440.00	180
712 8M HL•	712.00	89	1520 8M HL•	1520.00	190
720 8M HL	720.00	90	1552 8M HL•	1552.00	194
760 8M HL•	760.00	95	1584 8M HL•	1584.00	198
776 8M HL	776.00	97	1600 8M HL	1600.00	200
784 8M HL	784.00	98	1680 8M HL•	1680.00	210
800 8M HL	800.00	100	1696 8M HL•	1696.00	212
824 8M HL•	824.00	103	1728 8M HL•	1728.00	216
840 8M HL•	840.00	105	1760 8M HL	1760.00	220
848 8M HL•	848.00	106	1800 8M HL	1800.00	225
856 8M HL•	856.00	107	1904 8M HL•	1904.00	238
880 8M HL	880.00	110	1936 8M HL•	1936.00	242
896 8M HL•	896.00	112	2000 8M HL	2000.00	250
912 8M HL	912.00	114	2080 8M HL•	2080.00	260
920 8M HL	920.00	115	2104 8M HL•	2104.00	263
960 8M HL	960.00	120	2240 8M HL	2240.00	280
976 8M HL•	976.00	122	2248 8M HL•	2248.00	281
1000 8M HL•	1000.00	125	2272 8M HL•	2272.00	284
1040 8M HL	1040.00	130	2400 8M HL	2400.00	300
1056 8M HL•	1056.00	132	2504 8M HL•	2504.00	313
1064 8M HL•	1064.00	133	2600 8M HL	2600.00	325
1080 8M HL•	1080.00	135	2800 8M HL	2800.00	350
1096 8M HL•	1096.00	137	3280 8M HL•	3280.00	410
1120 8M HL	1120.00	140			
1128 8M HL•	1128.00	141			

Standard widths: 20 mm, 30 mm, 50 mm, 85 mm
(additional lengths and special widths on request)
• Non stock items

Order example:

Timing belt: Optibelt OMEGA HL 1200 8M HL 20

 1200 = 1200 mm pitch length
 8M HL = section and construction
 20 = 20 mm belt width

Product Description

optibelt OMEGA HL Timing Belts

Standard Range



Power Transmission

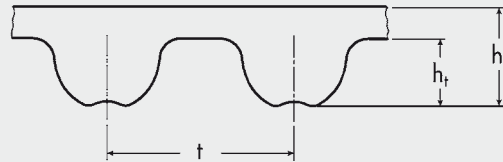

Section	14M HL
t [mm]	14.0
h _s [mm]	9.5
h _t [mm]	5.6

Optibelt OMEGA 14M HL

Belt designation	Pitch length [mm]	Number of teeth	Belt designation	Pitch length [mm]	Number of teeth
966 14M HL•	966.00	69	2450 14M HL•	2450.00	175
1092 14M HL•	1092.00	78	2590 14M HL•	2590.00	185
1190 14M HL•	1190.00	85	2800 14M HL•	2800.00	200
1400 14M HL•	1400.00	100	3150 14M HL•	3150.00	225
1456 14M HL•	1456.00	104	3360 14M HL•	3360.00	240
1610 14M HL•	1610.00	115	3500 14M HL•	3500.00	250
1778 14M HL•	1778.00	127	3850 14M HL•	3850.00	275
1890 14M HL•	1890.00	135	4326 14M HL•	4326.00	309
2100 14M HL•	2100.00	150	4578 14M HL•	4578.00	327
2310 14M HL•	2310.00	165			

Standard widths: 40 mm, 55 mm, 85 mm, 115 mm, 170 mm
 (additional lengths and special widths on request) • Non stock items

Order example:

Timing belt: Optibelt OMEGA HL 1400 14M HL 40

1400 = 1400 mm pitch length
 14M HL = section and construction
 40 = 40 mm belt width

Product Description

optibelt *OMEGA* FanPower Timing Belts



Power Transmission

Construction

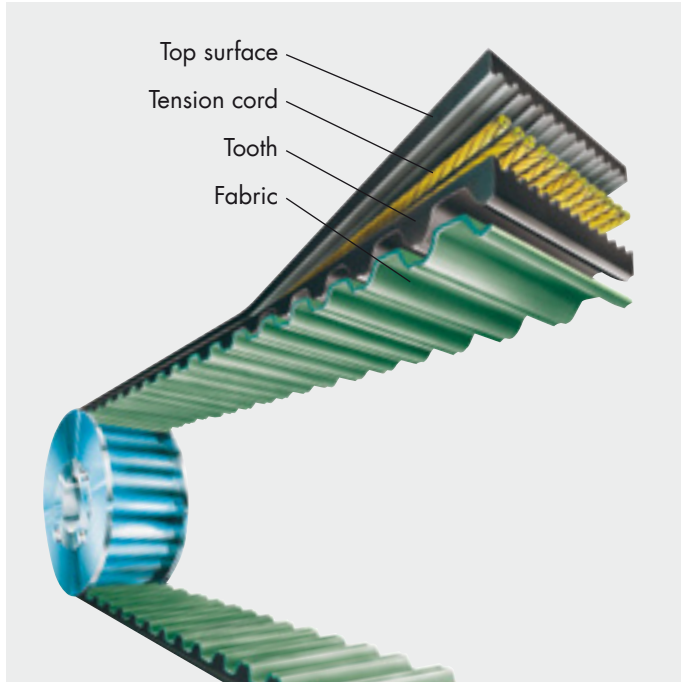

The high-performance timing belt for fan drives in the oil industry

Fan drives in the oil industry with medium and high transmission ratios are expected to meet some demanding requirements:

- antistatic according to ISO 9563
- optimized for low wear engagement in gear teeth
- long service life
- maintenance-free
- high level of efficiency
- constant flow of air thanks to synchronous operation
- resistant to external influences such as variations in temperature and moisture

Optibelt OMEGA, OMEGA HP, OMEGA HL and OMEGA FanPower timing belts are used in Optibelt ZRS timing pulleys in HTD® profiles or in RPP®. For applications in other pulleys please consult Optibelt Application Engineering Department.

Top surface

A durable and flexible top surface protects the corpus of the belt from external influences. Furthermore, the polychloroprene top surface is reinforced with aramide fibers, giving it partial resistance to mineral oils and moisture, as well as protecting against wear and tear due to friction.

Tension cord

The tension element consists of reinforced twisted pairs of fiberglass tension cords running in opposite directions. These tension cords are characterized by high tensile strength, excellent flexibility and very low stretch.

Teeth

The teeth are made from a new type of combination of materials with aramide fibers that guarantees a high resistance to shearing. They are shaped and divided in such a way that they engage exactly in the spaces between the pulley teeth, causing minimal friction. The grooving in the teeth promotes quiet operation.

Fabric

The specially developed polyamide-fabric features an extraordinarily low frictional coefficient and leads to extremely quiet operations. It also protects the teeth from early wear and tear, as well as preventing break-outs.



Product Description

optibelt OMEGA FanPower Timing Belts

Standard Range



(nominal dimensions – mm)

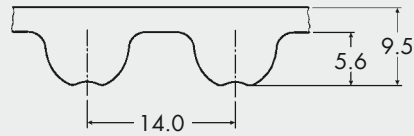
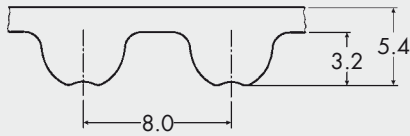

Optibelt OMEGA FanPower 8M FP			Optibelt OMEGA FanPower 14M FP		
Belt designation	Pitch length [mm]	Number of teeth	Belt designation	Pitch length [mm]	Number of teeth
2000 8M FP•	2000.00	250	3150 14M FP•	3150.00	225
2240 8M FP•	2240.00	280	3360 14M FP•	3360.00	240
2400 8M FP•	2400.00	300	3500 14M FP•	3500.00	250
2600 8M FP•	2600.00	325	3850 14M FP•	3850.00	275
2800 8M FP•	2800.00	350	4326 14M FP•	4326.00	309
			4578 14M FP•	4578.00	327

<p>Standard widths: 30 mm, 50 mm, 85 mm (additional lengths and special widths on request)</p> <ul style="list-style-type: none"> • Non stock items 	<p>Standard widths: 55 mm, 85 mm (additional lengths and special widths on request)</p>
---	--

Order example:

Timing belt: Optibelt OMEGA FanPower 2000 8M FP 30

2000 = 2000 mm pitch length
 8M FP = section and construction
 30 = 30 mm belt width

Product Description

optibelt **OMEGA HP** Timing Belts



Power Transmission

Construction

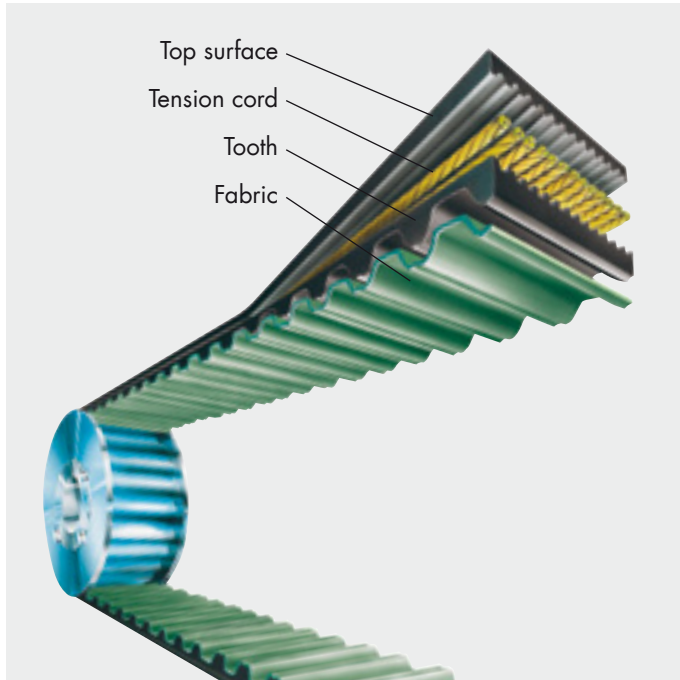

Top surface

A durable and flexible top surface protects the tension cord from external influences. In addition, the polychloroprene compound is reinforced with aramid fibres and moderately resistant to mineral oils and humidity and protects from wear due to friction.

Tension cord

The tension cords are reinforced glass fibres counter twisted and laid in pairs. These tension cords have very high tensile strength, very high flexibility and minimal stretch.

Teeth

The teeth consist of a new compound reinforced with aramid fibres, which guarantee high shear strength. They are shaped in such a way and exactly spaced so that they mesh perfectly with the pulley teeth with minimal friction. The indent in the tooth tip promotes quiet running.

Fabric

The specially designed polyamide fabric distinguishes itself by its extraordinarily low friction coefficient and its low noise characteristics. This fabric also protects the teeth from premature wear and cracking.

The high performance timing belt for high load, high speed machine drives

Compact synchronous drives are used in the whole field of mechanical drive engineering. High power transmission capability, good running characteristics and high operational safety are only some of the demands made on timing belts. Modern manufacturing techniques and quality inspections during all processing stages ensure products of the highest reliability. Optibelt OMEGA HP high performance timing belts have been especially developed for high load, low and high speed drives that are evenly loaded without heavy shock. Improved materials and optimised production form the basis for this very high performance spectrum.

Optibelt OMEGA, OMEGA HP and OMEGA HL timing belts are used in Optibelt ZRS HTD® pulleys or in RPP® pulleys. For the applications using other pulleys, please contact the Optibelt Applications Engineering Department.



Example of application: test bench

The new high performance timing belt Optibelt OMEGA 5M HP

In the field of the high performance timing belts OMEGA HP the Optibelt OMEGA 5M HP has been newly developed for small pulley diameters, short centre distances and high speeds.

The Optibelt OMEGA 5M HP transmits up to 3 times the power of an Optibelt OMEGA 5M (an increase in power of up to 200%). The performance level of the Optibelt OMEGA 5M HP corresponds – with the same pulley diameters – roughly to the level of the considerably larger section Optibelt OMEGA 8M.

Product Description

optibelt **OMEGA HP** Timing Belts

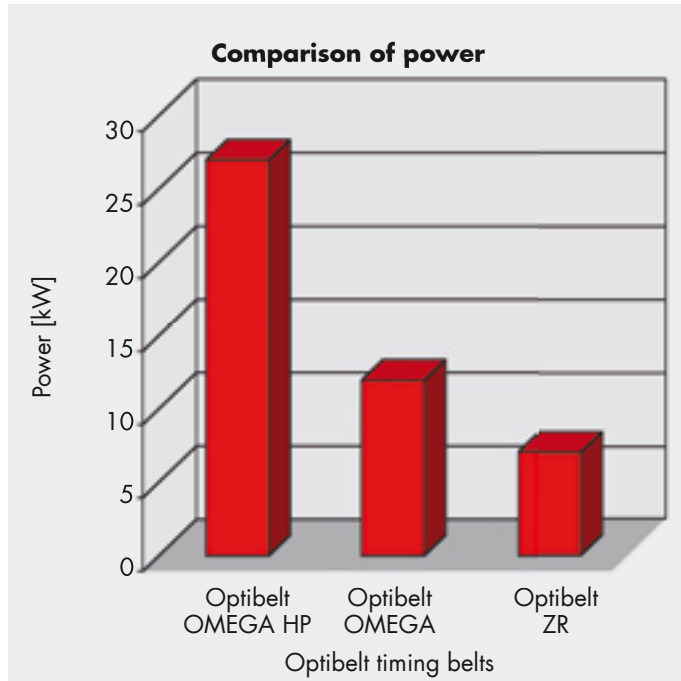

Comparing power ratings

Section and construction	8M HP	8M	H
Pitch [mm]	8	8	12.7
Width [mm]	20	20	19.05
Pulley diameter [mm]	96.77	96.77	97.02
Speed [min ⁻¹]	2850	2850	2850
Nominal power [kW]	24.4	10.8	6.0

Preferred areas of application

- Textile machines
- Machine tools
- Compressors
- Printing machines
- Wood working machines
- Paper machines

Overview of the advantages and characteristics of the Optibelt OMEGA HP

- dimensionally stable construction with high flexibility
- low residual and elastic stretch of the cord
- friction and abrasion resistant fabric with high shear strength, thus,
- approximately double the power transmission capability, (section 5M HP approximately treble the power transmission capacity) compared to OMEGA timing belts in their standard construction
- suitable for low and high speed, high load drives
- good resistance and smooth operation, low and medium shock load
- large range of applications
- electrical conductivity according to ISO 9563 can be proven on request

Advantages and characteristics of a drive with Optibelt OMEGA HP timing belts in these areas of application

- considerably reduced drive volume compared to OMEGA timing belts in standard construction, thus,
- reduced costs for belts and pulleys
- greater options for drive design
- reduced shaft diameters and smaller bearings
- reduced running noise levels
- improved efficiency

Significant cost reduction for the system and high operational reliability for optimum efficiency of the new drives

For additional advantages and characteristics, see Optibelt OMEGA on page 20.

Product Description

optibelt OMEGA HP Timing Belts

Standard Range



Power Transmission

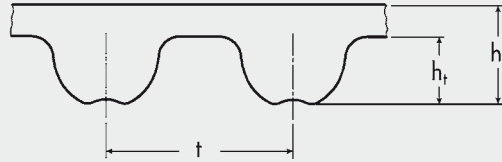

Section	3M HP
t [mm]	3.0
h _s [mm]	2.3
h _t [mm]	1.1

Optibelt OMEGA 3M HP

Belt designation	Pitch length [mm]	Number of teeth	Belt designation	Pitch length [mm]	Number of teeth	Belt designation	Pitch length [mm]	Number of teeth
111 3M HP•	111.00	37	315 3M HP•	315.00	105	615 3M HP•	615.00	205
129 3M HP•	129.00	43	318 3M HP•	318.00	106	633 3M HP•	633.00	211
141 3M HP•	141.00	47	330 3M HP•	330.00	110	669 3M HP•	669.00	223
144 3M HP•	144.00	48	333 3M HP•	333.00	111	675 3M HP•	675.00	225
150 3M HP•	150.00	50	339 3M HP•	339.00	113	711 3M HP•	711.00	237
159 3M HP•	159.00	53	345 3M HP•	345.00	115	738 3M HP•	738.00	246
165 3M HP•	165.00	55	357 3M HP•	357.00	119	804 3M HP•	804.00	268
168 3M HP•	168.00	56	363 3M HP•	363.00	121	816 3M HP•	816.00	272
171 3M HP•	171.00	57	366 3M HP•	366.00	122	843 3M HP•	843.00	281
174 3M HP•	174.00	58	384 3M HP•	384.00	128	882 3M HP•	882.00	294
177 3M HP•	177.00	59	390 3M HP•	390.00	130	888 3M HP•	888.00	296
180 3M HP•	180.00	60	411 3M HP•	411.00	137	1062 3M HP•	1062.00	354
183 3M HP•	183.00	61	420 3M HP•	420.00	140	1569 3M HP•	1569.00	523
186 3M HP•	186.00	62	426 3M HP•	426.00	142	1587 3M HP•	1587.00	529
192 3M HP•	192.00	64	435 3M HP•	435.00	145			
195 3M HP•	195.00	65	447 3M HP•	447.00	149			
201 3M HP•	201.00	67	462 3M HP•	462.00	154			
204 3M HP•	204.00	68	474 3M HP•	474.00	158			
207 3M HP•	207.00	69	480 3M HP•	480.00	160			
210 3M HP•	210.00	70	486 3M HP•	486.00	162			
213 3M HP•	213.00	71	495 3M HP•	495.00	165			
225 3M HP•	225.00	75	501 3M HP•	501.00	167			
240 3M HP•	240.00	80	513 3M HP•	513.00	171			
249 3M HP•	249.00	83	519 3M HP•	519.00	173			
252 3M HP•	252.00	84	522 3M HP•	522.00	174			
255 3M HP•	255.00	85	525 3M HP•	525.00	175			
267 3M HP•	267.00	89	531 3M HP•	531.00	177			
276 3M HP•	276.00	92	537 3M HP•	537.00	179			
282 3M HP•	282.00	94	558 3M HP•	558.00	186			
285 3M HP•	285.00	95	564 3M HP•	564.00	188			
288 3M HP•	288.00	96	570 3M HP•	570.00	190			
291 3M HP•	291.00	97	582 3M HP•	582.00	194			
294 3M HP•	294.00	98	597 3M HP•	597.00	199			
300 3M HP•	300.00	100	600 3M HP•	600.00	200			
312 3M HP•	312.00	104	606 3M HP•	606.00	202			

Standard widths: 6 mm, 9 mm, 15 mm
 (additional lengths and special widths on request) • Non stock items

Order example:

Timing belt: Optibelt OMEGA HP 225 3M HP 9

225 = 225 mm pitch length
 3M HP = section and construction
 9 = 9 mm belt width

Product Description

optibelt OMEGA HP Timing Belts

Standard Range



Power Transmission

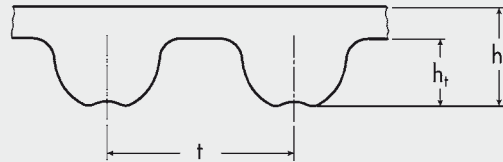

Section	5M HP
t [mm]	5.0
h _s [mm]	3.4
h _t [mm]	1.9

Optibelt OMEGA 5M HP

Belt designation	Pitch length [mm]	Number of teeth	Belt designation	Pitch length [mm]	Number of teeth	Belt designation	Pitch length [mm]	Number of teeth
180 5M HP	180.00	36	610 5M HP•	610.00	122	1050 5M HP	1050.00	210
225 5M HP	225.00	45	615 5M HP•	615.00	123	1100 5M HP•	1100.00	220
255 5M HP	255.00	51	630 5M HP	630.00	126	1125 5M HP	1125.00	225
265 5M HP	265.00	53	635 5M HP	635.00	127	1135 5M HP•	1135.00	227
270 5M HP•	270.00	54	640 5M HP•	640.00	128	1200 5M HP•	1200.00	240
280 5M HP•	280.00	56	645 5M HP•	645.00	129	1270 5M HP•	1270.00	254
295 5M HP•	295.00	59	650 5M HP•	650.00	130	1380 5M HP•	1380.00	276
300 5M HP•	300.00	60	665 5M HP	665.00	133	1400 5M HP•	1400.00	280
305 5M HP	305.00	61	670 5M HP•	670.00	134	1420 5M HP	1420.00	284
325 5M HP•	325.00	65	700 5M HP	700.00	140	1425 5M HP•	1425.00	285
330 5M HP	330.00	66	710 5M HP	710.00	142	1500 5M HP•	1500.00	300
340 5M HP•	340.00	68	720 5M HP•	720.00	144	1595 5M HP•	1595.00	319
350 5M HP	350.00	70	740 5M HP	740.00	148	1690 5M HP•	1690.00	338
360 5M HP	360.00	72	750 5M HP•	750.00	150	1790 5M HP•	1790.00	358
365 5M HP•	365.00	73	755 5M HP	755.00	151	1870 5M HP•	1870.00	374
370 5M HP•	370.00	74	775 5M HP•	775.00	155	1895 5M HP•	1895.00	379
375 5M HP	375.00	75	790 5M HP•	790.00	158	2000 5M HP•	2000.00	400
385 5M HP•	385.00	77	800 5M HP	800.00	160	2110 5M HP•	2110.00	422
400 5M HP	400.00	80	825 5M HP•	825.00	165	2350 5M HP•	2350.00	470
415 5M HP•	415.00	83	830 5M HP•	830.00	166	2525 5M HP•	2525.00	505
425 5M HP	425.00	85	835 5M HP	835.00	167			
450 5M HP	450.00	90	850 5M HP•	850.00	170			
475 5M HP	475.00	95	860 5M HP•	860.00	172			
490 5M HP•	490.00	98	890 5M HP	890.00	178			
500 5M HP	500.00	100	900 5M HP	900.00	180			
520 5M HP•	520.00	104	925 5M HP	925.00	185			
525 5M HP	525.00	105	935 5M HP•	935.00	187			
535 5M HP	535.00	107	940 5M HP•	940.00	188			
540 5M HP•	540.00	108	950 5M HP	950.00	190			
550 5M HP	550.00	110	965 5M HP•	965.00	193			
560 5M HP•	560.00	112	975 5M HP•	975.00	195			
565 5M HP	565.00	113	980 5M HP•	980.00	196			
575 5M HP•	575.00	115	1000 5M HP	1000.00	200			
580 5M HP•	580.00	116	1025 5M HP•	1025.00	205			
600 5M HP	600.00	120	1035 5M HP•	1035.00	207			

Standard widths: 9 mm, 15 mm, 25 mm
(additional lengths and special widths on request) • Non stock items

Order example:

Timing belt: Optibelt OMEGA HP 1000 5M HP 25

1000 = 1000 mm pitch length
5M HP = section and construction
25 = 25 mm belt width

Product Description

optibelt OMEGA HP Timing Belts

Standard Range



Power Transmission

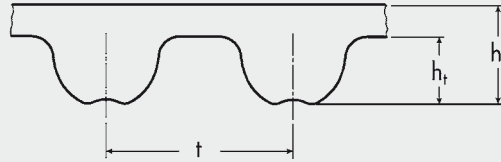

Section	8M HP
t [mm]	8.0
h _s [mm]	5.4
h _t [mm]	3.2

Optibelt OMEGA 8M HP

Belt designation	Pitch length [mm]	Number of teeth	Belt designation	Pitch length [mm]	Number of teeth	Belt designation	Pitch length [mm]	Number of teeth
288 8M HP•	288.00	36	1064 8M HP	1064.00	133	2240 8M HP	2240.00	280
352 8M HP•	352.00	44	1080 8M HP	1080.00	135	2248 8M HP	2248.00	281
376 8M HP•	376.00	47	1096 8M HP•	1096.00	137	2272 8M HP	2272.00	284
416 8M HP•	416.00	52	1120 8M HP	1120.00	140	2400 8M HP	2400.00	300
424 8M HP	424.00	53	1128 8M HP	1128.00	141	2504 8M HP	2504.00	313
480 8M HP	480.00	60	1160 8M HP	1160.00	145	2600 8M HP	2600.00	325
512 8M HP•	512.00	64	1184 8M HP•	1184.00	148	2800 8M HP	2800.00	350
520 8M HP•	520.00	65	1200 8M HP	1200.00	150	3280 8M HP	3280.00	410
560 8M HP	560.00	70	1216 8M HP	1216.00	152			
576 8M HP•	576.00	72	1224 8M HP	1224.00	153			
600 8M HP	600.00	75	1248 8M HP•	1248.00	156			
608 8M HP•	608.00	76	1256 8M HP•	1256.00	157			
632 8M HP•	632.00	79	1264 8M HP•	1264.00	158			
640 8M HP	640.00	80	1280 8M HP	1280.00	160			
656 8M HP	656.00	82	1304 8M HP	1304.00	163			
680 8M HP	680.00	85	1328 8M HP•	1328.00	166			
712 8M HP•	712.00	89	1344 8M HP•	1344.00	168			
720 8M HP	720.00	90	1360 8M HP	1360.00	170			
760 8M HP	760.00	95	1400 8M HP	1400.00	175			
776 8M HP•	776.00	97	1424 8M HP	1424.00	178			
784 8M HP•	784.00	98	1440 8M HP	1440.00	180			
800 8M HP	800.00	100	1520 8M HP	1520.00	190			
824 8M HP•	824.00	103	1552 8M HP	1552.00	194			
840 8M HP	840.00	105	1584 8M HP•	1584.00	198			
848 8M HP•	848.00	106	1600 8M HP	1600.00	200			
856 8M HP•	856.00	107	1680 8M HP•	1680.00	210			
880 8M HP	880.00	110	1696 8M HP	1696.00	212			
896 8M HP•	896.00	112	1728 8M HP•	1728.00	216			
912 8M HP•	912.00	114	1760 8M HP	1760.00	220			
920 8M HP	920.00	115	1800 8M HP	1800.00	225			
960 8M HP	960.00	120	1904 8M HP•	1904.00	238			
976 8M HP•	976.00	122	1936 8M HP	1936.00	242			
1000 8M HP	1000.00	125	2000 8M HP	2000.00	250			
1040 8M HP	1040.00	130	2080 8M HP•	2080.00	260			
1056 8M HP•	1056.00	132	2104 8M HP•	2104.00	263			

Standard widths: 20 mm, 30 mm, 50 mm, 85 mm
 (additional lengths and special widths on request) • Non stock items

Order example:

Timing belt: Optibelt OMEGA HP 1200 8M HP 20

1200 = 1200 mm pitch length
 8M HP = section and construction
 20 = 20 mm belt width

Product Description

optibelt OMEGA HP Timing Belts

Standard Range



Power Transmission

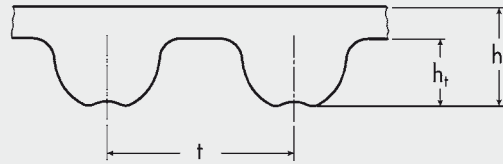

Section	14M HP
t [mm]	14.0
h _s [mm]	9.5
h _t [mm]	5.6

Optibelt OMEGA 14M HP

Belt designation	Pitch length [mm]	Number of teeth	Belt designation	Pitch length [mm]	Number of teeth
966 14M HP	966.00	69	2450 14M HP	2450.00	175
1092 14M HP	1092.00	78	2590 14M HP	2590.00	185
1190 14M HP	1190.00	85	2800 14M HP	2800.00	200
1400 14M HP	1400.00	100	3150 14M HP	3150.00	225
1456 14M HP•	1456.00	104	3360 14M HP	3360.00	240
1610 14M HP	1610.00	115	3500 14M HP	3500.00	250
1778 14M HP	1778.00	127	3850 14M HP	3850.00	275
1890 14M HP	1890.00	135	4326 14M HP	4326.00	309
2100 14M HP	2100.00	150	4578 14M HP	4578.00	327
2310 14M HP	2310.00	165			

Standard widths: 40 mm, 55 mm, 85 mm, 115 mm, 170 mm
(additional lengths and special widths on request) • Non stock items

Order example:

Timing belt: Optibelt OMEGA HP 1400 14M HP 55

1400 = 1400 mm pitch length
14M HP = section and construction
55 = 55 mm belt width

Product Description

optibelt *OMEGA* Timing Belts



Power Transmission

Construction

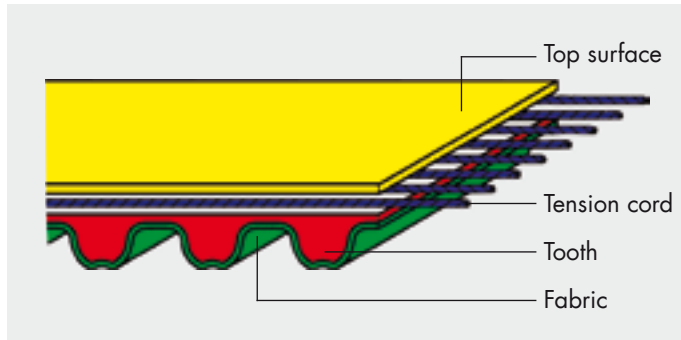

Top surface

The belt top surface consists of a flexible polychloroprene compound which protects the tension cord from external influences. In addition, it is moderately resistant to mineral oils, humidity and protects from frictional wear.

Tension cord

The tension member is composed of glass fibre tension cords counter twisted and laid in pairs. These tension cords have high tensile strength, very high flexibility and very low stretch.

Teeth

Just like the belt top surface, the teeth consist of a polychloroprene compound guaranteeing high shear strength. The indent in the tooth tip promotes quiet running.

Fabric

The polyamide fabric protects the tooth from premature wear and prevents cracking. At the same time, the low coefficient of friction lowers operating temperature and helps to reduce running noise levels.

High performance Optibelt OMEGA timing belts are the result of a continuing development process. Operational experience with Optibelt ZR and Optibelt HTD® has been applied to this belt generation. Endless Optibelt OMEGA timing belts set the standard for synchronous performance and for positioning drives.

The geometry of the Optibelt OMEGA tooth profile has been adjusted to the established, curvilinear timing pulleys. You can use, for example, Optibelt OMEGA timing belts in HTD® timing pulleys in the pulley sections 3M, 5M, 8M and 14M. Optibelt ZRS HTD® timing pulleys are standard items in our range with pilot bores or bored for Optibelt TB taper bushes. In addition, all OMEGA timing belts can also be used in RPP® timing pulleys. Special timing pulleys for Optibelt OMEGA timing belts are not required.

Double timing belts for drives with reversible speed can be delivered with HTD® sections. Double timing belts with Optibelt OMEGA sections on request. Power ratings see page 46-48.



Example of application: lawn mowers

Overview of the advantages and characteristics

- synchronous speed
- highest precision
- perceptibly lower noise level due to the OMEGA tooth profile
- may be used in standard HTD® and RPP® timing pulleys
- maintenance-free
- temperature resistant from -30 °C to +100 °C
- efficiency of up to 98%

Product Description

optibelt *OMEGA* Timing Belts

Standard Range



Power Transmission

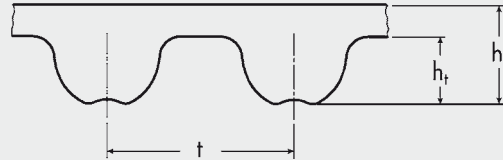

Section	2M
t [mm]	2.0
h _s [mm]	1.3
h _t [mm]	0.7

Optibelt OMEGA 2M

Belt designation	Pitch length [mm]	Number of teeth	Belt designation	Pitch length [mm]	Number of teeth
74 2M•	74.00	37	280 2M•	280.00	140
90 2M•	90.00	45	288 2M•	288.00	144
100 2M•	100.00	50	304 2M•	304.00	152
104 2M•	104.00	52	308 2M•	308.00	154
112 2M•	112.00	56	310 2M•	310.00	155
118 2M•	118.00	59	318 2M•	318.00	159
120 2M•	120.00	60	328 2M•	328.00	164
124 2M•	124.00	62	330 2M•	330.00	165
130 2M•	130.00	65	336 2M•	336.00	168
140 2M•	140.00	70	340 2M•	340.00	170
148 2M•	148.00	74	368 2M•	368.00	184
180 2M•	180.00	90	370 2M•	370.00	185
184 2M•	184.00	92	386 2M•	386.00	193
188 2M•	188.00	94	392 2M•	392.00	196
192 2M•	192.00	96	406 2M•	406.00	203
200 2M•	200.00	100	426 2M•	426.00	213
208 2M•	208.00	104	448 2M•	448.00	224
210 2M•	210.00	105	558 2M•	558.00	279
216 2M•	216.00	108	560 2M•	560.00	280
224 2M•	224.00	112	710 2M•	710.00	355
232 2M•	232.00	116	930 2M•	930.00	465
250 2M•	250.00	125	984 2M•	984.00	492
256 2M•	256.00	128	1066 2M•	1066.00	533
266 2M•	266.00	133	1224 2M•	1224.00	612
274 2M•	274.00	137			

Standard widths: 3 mm, 6 mm, 9 mm
 • Non stock items

Order example:

Timing belt: Optibelt OMEGA 180 2M 6

180 = 180 mm pitch length
 2M = section
 6 = 6 mm belt width

Product Description

optibelt OMEGA Timing Belts

Standard Range



Power Transmission

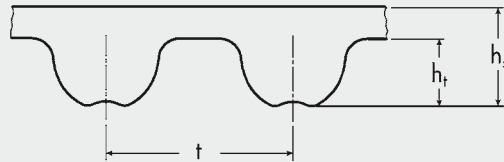

Section	3M
t [mm]	3.0
h _s [mm]	2.3
h _t [mm]	1.1

Optibelt OMEGA 3M

Belt designation	Pitch length [mm]	Number of teeth	Belt designation	Pitch length [mm]	Number of teeth	Belt designation	Pitch length [mm]	Number of teeth
111 3M	111.00	37	291 3M	291.00	97	591 3M (HTD)•	591.00	197
117 3M (HTD)•	117.00	39	294 3M	294.00	98	594 3M (HTD)•	594.00	198
120 3M (HTD)•	120.00	40	300 3M	300.00	100	597 3M	597.00	199
123 3M (HTD)•	123.00	41	306 3M (HTD)•	306.00	102	600 3M	600.00	200
126 3M (HTD)•	126.00	42	312 3M	312.00	104	606 3M	606.00	202
129 3M	129.00	43	315 3M	315.00	105	612 3M (HTD)•	612.00	204
141 3M	141.00	47	318 3M	318.00	106	615 3M	615.00	205
144 3M	144.00	48	330 3M	330.00	110	633 3M	633.00	211
150 3M	150.00	50	333 3M	333.00	111	648 3M (HTD)•	648.00	216
156 3M (HTD)•	156.00	52	336 3M (HTD)	336.00	112	669 3M	669.00	223
159 3M	159.00	53	339 3M	339.00	113	672 3M (HTD)•	672.00	224
165 3M	165.00	55	345 3M	345.00	115	675 3M	675.00	225
168 3M	168.00	56	357 3M	357.00	119	708 3M (HTD)•	708.00	236
171 3M	171.00	57	363 3M	363.00	121	711 3M	711.00	237
174 3M	174.00	58	366 3M	366.00	122	738 3M	738.00	246
177 3M	177.00	59	384 3M	384.00	128	753 3M (HTD)	753.00	251
180 3M	180.00	60	390 3M	390.00	130	804 3M	804.00	268
183 3M	183.00	61	411 3M	411.00	137	816 3M	816.00	272
186 3M	186.00	62	420 3M	420.00	140	843 3M	843.00	281
192 3M	192.00	64	426 3M	426.00	142	882 3M	882.00	294
195 3M	195.00	65	435 3M•	435.00	145	888 3M	888.00	296
201 3M	201.00	67	447 3M	447.00	149	945 3M (HTD)	945.00	315
204 3M	204.00	68	462 3M	462.00	154	960 3M (HTD)•	960.00	320
207 3M	207.00	69	474 3M	474.00	158	1041 3M (HTD)•	1041.00	347
210 3M	210.00	70	477 3M (HTD)•	477.00	159	1062 3M	1062.00	354
213 3M	213.00	71	480 3M	480.00	160	1068 3M (HTD)•	1068.00	356
216 3M (HTD)	216.00	72	486 3M	486.00	162	1071 3M (HTD)	1071.00	357
225 3M	225.00	75	489 3M (HTD)•	489.00	163	1125 3M (HTD)•	1125.00	375
237 3M (HTD)•	237.00	79	495 3M	495.00	165	1176 3M (HTD)•	1176.00	392
240 3M	240.00	80	501 3M	501.00	167	1245 3M (HTD)•	1245.00	415
243 3M (HTD)•	243.00	81	513 3M	513.00	171	1263 3M (HTD)	1263.00	421
246 3M (HTD)	246.00	82	519 3M	519.00	173	1500 3M (HTD)•	1500.00	500
249 3M	249.00	83	522 3M	522.00	174	1530 3M (HTD)•	1530.00	510
252 3M	252.00	84	525 3M	525.00	175	1569 3M	1569.00	523
255 3M	255.00	85	531 3M	531.00	177	1863 3M (HTD)	1863.00	621
267 3M	267.00	89	537 3M	537.00	179			
276 3M	276.00	92	558 3M	558.00	186			
282 3M•	282.00	94	564 3M	564.00	188			
285 3M	285.00	95	570 3M	570.00	190			
288 3M	288.00	96	582 3M	582.00	194			

Standard widths: 6 mm, 9 mm, 15 mm

• Non stock items

Order example:

Timing belt: Optibelt OMEGA 150 3M 15

150 = 150 mm pitch length

3M = section

15 = 15 mm belt width

Product Description

optibelt OMEGA Timing Belts

Standard Range



Power Transmission

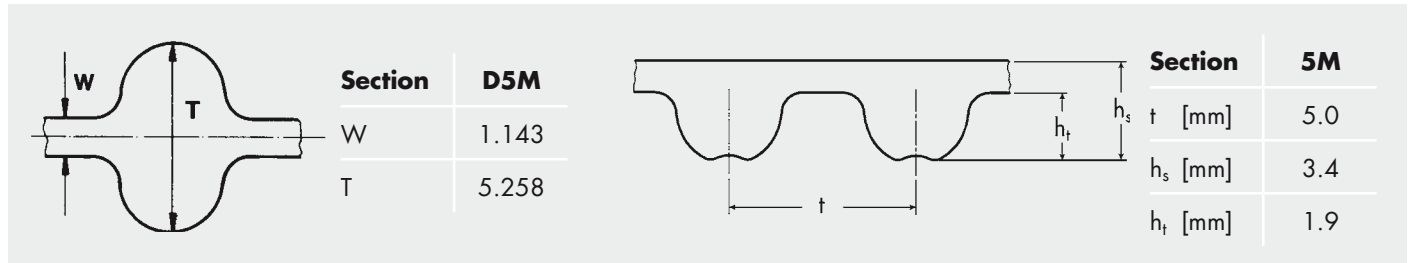

Optibelt OMEGA 5M

Belt designation	Pitch length [mm]	Number of teeth	Belt designation	Pitch length [mm]	Number of teeth	Belt designation	Pitch length [mm]	Number of teeth
120 5M (HTD)	120.00	24	575 5M	575.00	115	980 5M	980.00	196
180 5M	180.00	36	580 5M	580.00	116	1000 5M▲	1000.00	200
225 5M	225.00	45	600 5M▲	600.00	120	1025 5M	1025.00	205
255 5M	255.00	51	610 5M	610.00	122	1035 5M	1035.00	207
265 5M	265.00	53	615 5M▲	615.00	123	1050 5M▲	1050.00	210
270 5M	270.00	54	620 5M (HTD)	620.00	124	1100 5M	1100.00	220
280 5M	280.00	56	630 5M▲	630.00	126	1125 5M▲	1125.00	225
295 5M	295.00	59	635 5M▲	635.00	127	1135 5M	1135.00	227
300 5M	300.00	60	640 5M	640.00	128	1200 5M▲	1200.00	240
305 5M	305.00	61	645 5M	645.00	129	1270 5M	1270.00	254
325 5M	325.00	65	650 5M	650.00	130	1380 5M●	1380.00	276
330 5M	330.00	66	665 5M▲	665.00	133	1400 5M	1400.00	280
340 5M	340.00	68	670 5M	670.00	134	1420 5M	1420.00	284
345 5M (HTD)	345.00	69	700 5M▲	700.00	140	1425 5M	1425.00	285
350 5M	350.00	70	710 5M▲	710.00	142	1500 5M	1500.00	300
360 5M	360.00	72	720 5M	720.00	144	1595 5M	1595.00	319
365 5M	365.00	73	740 5M▲	740.00	148	1690 5M	1690.00	338
370 5M	370.00	74	750 5M	750.00	150	1790 5M	1790.00	358
375 5M	375.00	75	755 5M▲	755.00	151	1800 5M (HTD)●	1800.00	360
385 5M	385.00	77	775 5M	775.00	155	1870 5M	1870.00	374
400 5M	400.00	80	790 5M●	790.00	158	1895 5M	1895.00	379
415 5M	415.00	83	800 5M▲	800.00	160	2000 5M	2000.00	400
425 5M	425.00	85	825 5M	825.00	165	2110 5M	2110.00	422
450 5M	450.00	90	830 5M	830.00	166	2350 5M	2350.00	470
460 5M (HTD)	460.00	92	835 5M▲	835.00	167	2525 5M	2525.00	505
475 5M	475.00	95	850 5M	850.00	170			
490 5M	490.00	98	860 5M	860.00	172			
500 5M	500.00	100	890 5M▲	890.00	178			
520 5M	520.00	104	900 5M▲	900.00	180			
525 5M	525.00	105	925 5M▲	925.00	185			
535 5M	535.00	107	935 5M	935.00	187			
540 5M	540.00	108	940 5M	940.00	188			
550 5M	550.00	110	950 5M	950.00	190			
560 5M	560.00	112	965 5M	965.00	193			
565 5M▲	565.00	113	975 5M	975.00	195			

Standard widths: 9 mm, 15 mm, 25 mm
 ● Non stock items ▲ available as double toothed

Order example:

Timing belt: Optibelt OMEGA 1200 5M 15

1200 = 1200 mm pitch length
 5M = section
 15 = 15 mm belt width

Product Description

optibelt OMEGA Timing Belts

Standard Range



Power Transmission

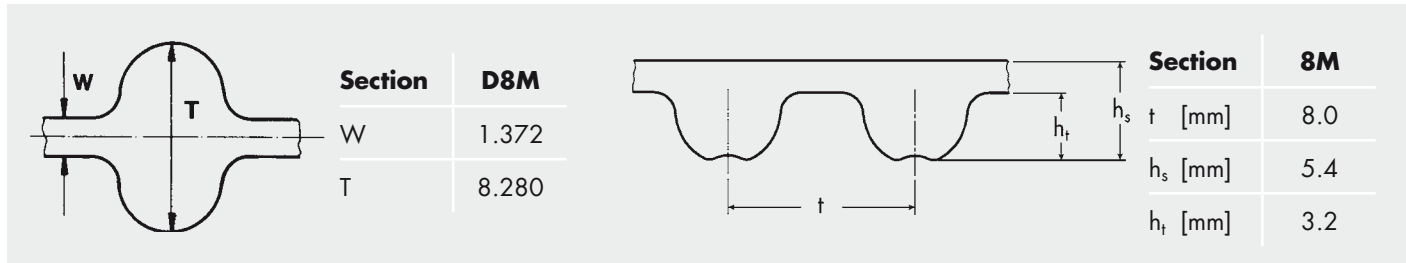

Optibelt OMEGA 8M

Belt designation	Pitch length [mm]	Number of teeth	Belt designation	Pitch length [mm]	Number of teeth	Belt designation	Pitch length [mm]	Number of teeth
288 8M●	288.00	36	1040 8M▲	1040.00	130	2000 8M▲	2000.00	250
320 8M (HTD)	320.00	40	1056 8M	1056.00	132	2080 8M	2080.00	260
352 8M●	352.00	44	1064 8M	1064.00	133	2104 8M	2104.00	263
376 8M	376.00	47	1080 8M	1080.00	135	2240 8M	2240.00	280
416 8M●	416.00	52	1096 8M	1096.00	137	2248 8M	2248.00	281
424 8M	424.00	53	1120 8M▲	1120.00	140	2272 8M	2272.00	284
480 8M	480.00	60	1128 8M	1128.00	141	2400 8M▲	2400.00	300
512 8M	512.00	64	1160 8M	1160.00	145	2504 8M	2504.00	313
520 8M	520.00	65	1184 8M	1184.00	148	2600 8M▲	2600.00	325
560 8M	560.00	70	1200 8M	1200.00	150	2800 8M▲	2800.00	350
576 8M	576.00	72	1216 8M	1216.00	152	3048 8M	3048.00	381
600 8M▲	600.00	75	1224 8M	1224.00	153	3280 8M	3280.00	410
608 8M	608.00	76	1248 8M	1248.00	156	3600 8M	3600.00	450
624 8M (HTD)	624.00	78	1256 8M	1256.00	157	4400 8M	4400.00	550
632 8M	632.00	79	1264 8M●	1264.00	158			
640 8M▲	640.00	80	1280 8M▲	1280.00	160			
656 8M▲	656.00	82	1304 8M▲	1304.00	163			
680 8M	680.00	85	1328 8M▲	1328.00	166			
712 8M	712.00	89	1344 8M	1344.00	168			
720 8M▲	720.00	90	1360 8M▲	1360.00	170			
760 8M	760.00	95	1400 8M	1400.00	175			
776 8M▲	776.00	97	1424 8M▲	1424.00	178			
784 8M▲	784.00	98	1432 8M (HTD)	1432.00	179			
800 8M▲	800.00	100	1440 8M▲	1440.00	180			
824 8M	824.00	103	1520 8M	1520.00	190			
840 8M	840.00	105	1552 8M	1552.00	194			
848 8M	848.00	106	1584 8M●	1584.00	198			
856 8M	856.00	107	1600 8M▲	1600.00	200			
880 8M▲	880.00	110	1680 8M	1680.00	210			
896 8M	896.00	112	1696 8M	1696.00	212			
912 8M	912.00	114	1728 8M	1728.00	216			
920 8M▲	920.00	115	1760 8M▲	1760.00	220			
960 8M▲	960.00	120	1800 8M▲	1800.00	225			
976 8M	976.00	122	1904 8M	1904.00	238			
1000 8M	1000.00	125	1936 8M	1936.00	242			

Standard widths: 20 mm, 30 mm, 50 mm, 85 mm

● Non stock items ▲ available as double toothed

Order example:

Timing belt: Optibelt OMEGA 1200 8M 50

1200 = 1200 mm pitch length

8M = section

50 = 50 mm belt width

Product Description

optibelt OMEGA Timing Belts

Standard Range



Power Transmission

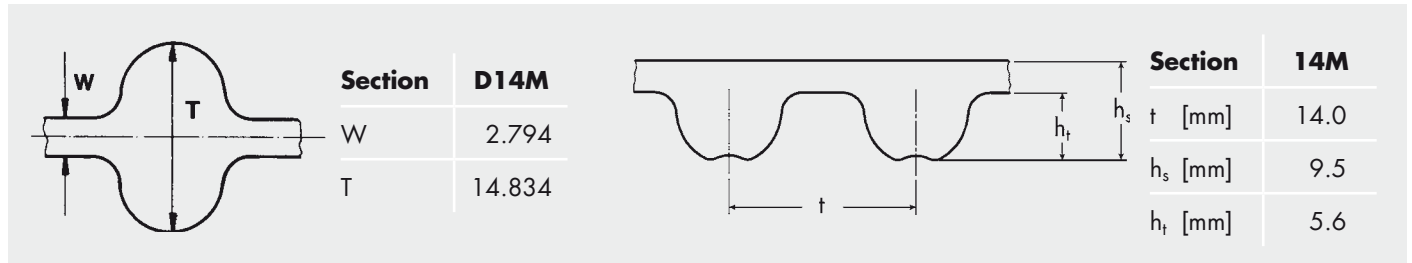

Optibelt OMEGA 14M

Belt designation	Pitch length [mm]	Number of teeth	Belt designation	Pitch length [mm]	Number of teeth
966 14M▲	966.00	69	2450 14M	2450.00	175
1092 14M	1092.00	78	2590 14M	2590.00	185
1190 14M▲	1190.00	85	2800 14M	2800.00	200
1400 14M▲	1400.00	100	3150 14M	3150.00	225
1456 14M●	1456.00	104	3360 14M	3360.00	240
1610 14M▲	1610.00	115	3500 14M	3500.00	250
1778 14M▲	1778.00	127	3850 14M	3850.00	275
1890 14M▲	1890.00	135	4004 14M (HTD)	4004.00	286
2100 14M▲	2100.00	150	4326 14M	4326.00	309
2310 14M▲	2310.00	165	4578 14M	4578.00	327

Standard widths: 40 mm, 55 mm, 85 mm, 115 mm, 170 mm
 ● Non stock items ▲ available as double toothed

Order example:

Timing belt: Optibelt OMEGA 1400 14M 55

1400 = 1400 mm pitch length
 14M = section
 55 = 55 mm belt width

Calculation

Timing Belts with **optibelt OMEGA** Sections

Explanation of the Symbols

Power Transmission

a	= centre distance	[mm]	P	= power to be transmitted by timing belt drive	[kW]
a_{nom}	= centre distance, calculated using a standard belt length	[mm]	P_B	= design power	[kW]
c_0	= basic service factor		P_N	= rated power	[kW]
c_1	= tooth in mesh factor		$P_{\dot{U}}$	= actual transmitted power for standard belt width [$P_N \cdot c_1 \cdot c_7$]	[kW]
c_2	= total service factor		S_a	= minimum static shaft force when stationary	[N]
c_3	= speed ratio correction factor		$S_{n\,zul}$	= maximum permissible circumferential force	[N]
c_6	= fatigue correction factor		S_{n3}	= circumferential force to be effectively transmitted	[N]
c_7	= belt length correction factor		S_n	= effective circumferential force to be transmitted incl. actual centrifugal force	[N]
d_a	= outside diameter of the timing belt pulley	[mm]	t	= tooth pitch	[mm]
d_w	= pitch diameter of the timing belt pulley	[mm]	v	= belt speed	[m/s]
d_{wg}	= pitch diameter of the large timing belt pulley	[mm]	x	= minimum adjustment of the drive centre distance a_{nom} for tensioning the timing belt	[mm]
d_{wk}	= pitch diameter of the small timing belt pulley	[mm]	y	= minimum adjustment of the drive centre distance a_{nom} for installation of the timing belt	[mm]
d_{w1}	= pitch diameter of the driving timing pulley	[mm]	z_e	= number of teeth in mesh on the small pulley	
d_{w2}	= pitch diameter of the driven timing belt pulley	[mm]	z_g	= number of teeth on the large pulley	
E_a	= belt deflection for given span length	[mm]	z_k	= number of teeth on the small pulley	
F	= force to create deflection	[N]	z_r	= number of teeth on the timing belt	
f	= frequency	[Hz]	z_1	= number of teeth on the driving pulley	
i	= speed ratio		z_2	= number of teeth on the driven pulley	
L	= drive span length	[mm]			
L_{wSt}	= standard pitch length of the timing belt	[mm]			
L_{wth}	= calculated pitch length of the timing belt	[mm]			
n_1	= speed frequency of the driving pulley	[min ⁻¹]			
n_2	= speed frequency of the driven pulley	[min ⁻¹]			

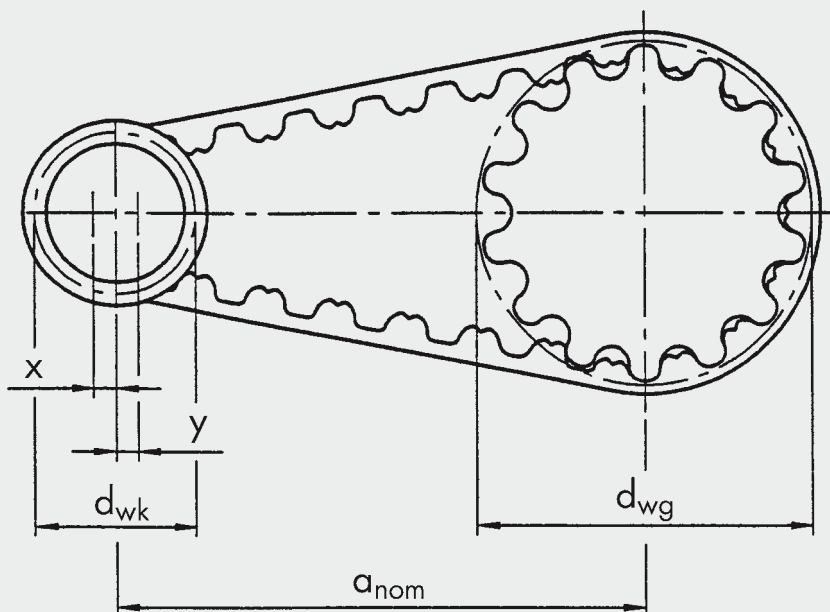

Calculation

optibelt OMEGA HL Timing Belts

Guidelines for the Selection



Diagram 1

see also
Optibelt CAP drive calculation
software at www.optibelt.com

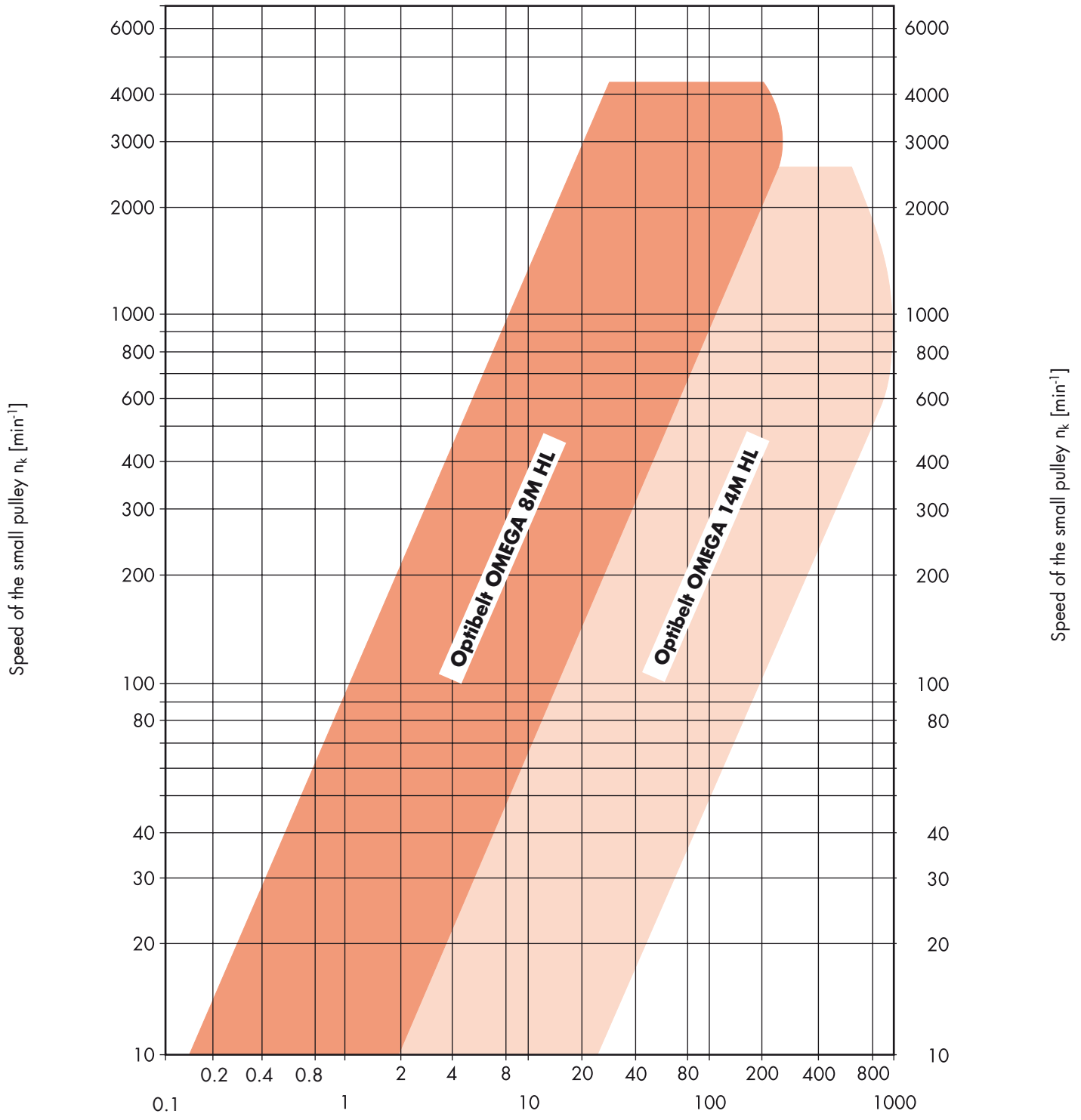

Design power $P_B = P \cdot c_2$ [kW]

Calculation

optibelt OMEGA HP, optibelt OMEGA FanPower Timing Belts

Guidelines for the Selection



Power Transmission

Diagram 2

see also
Optibelt CAP drive calculation
software at www.optibelt.com

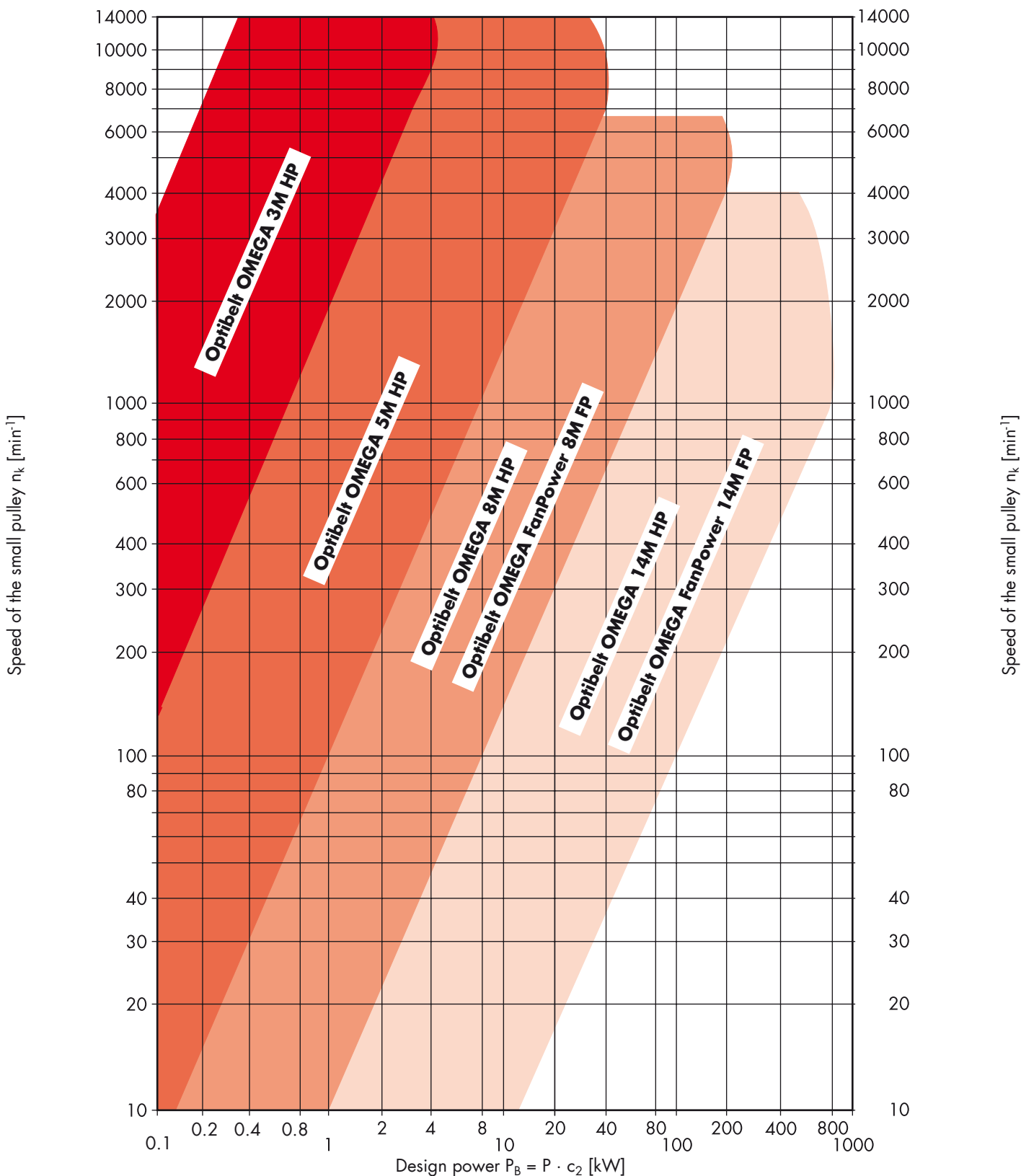

Calculation

optibelt OMEGA Timing Belts

Guidelines for the Selection



Diagram 3

see also
Optibelt CAP drive calculation
software at www.optibelt.com

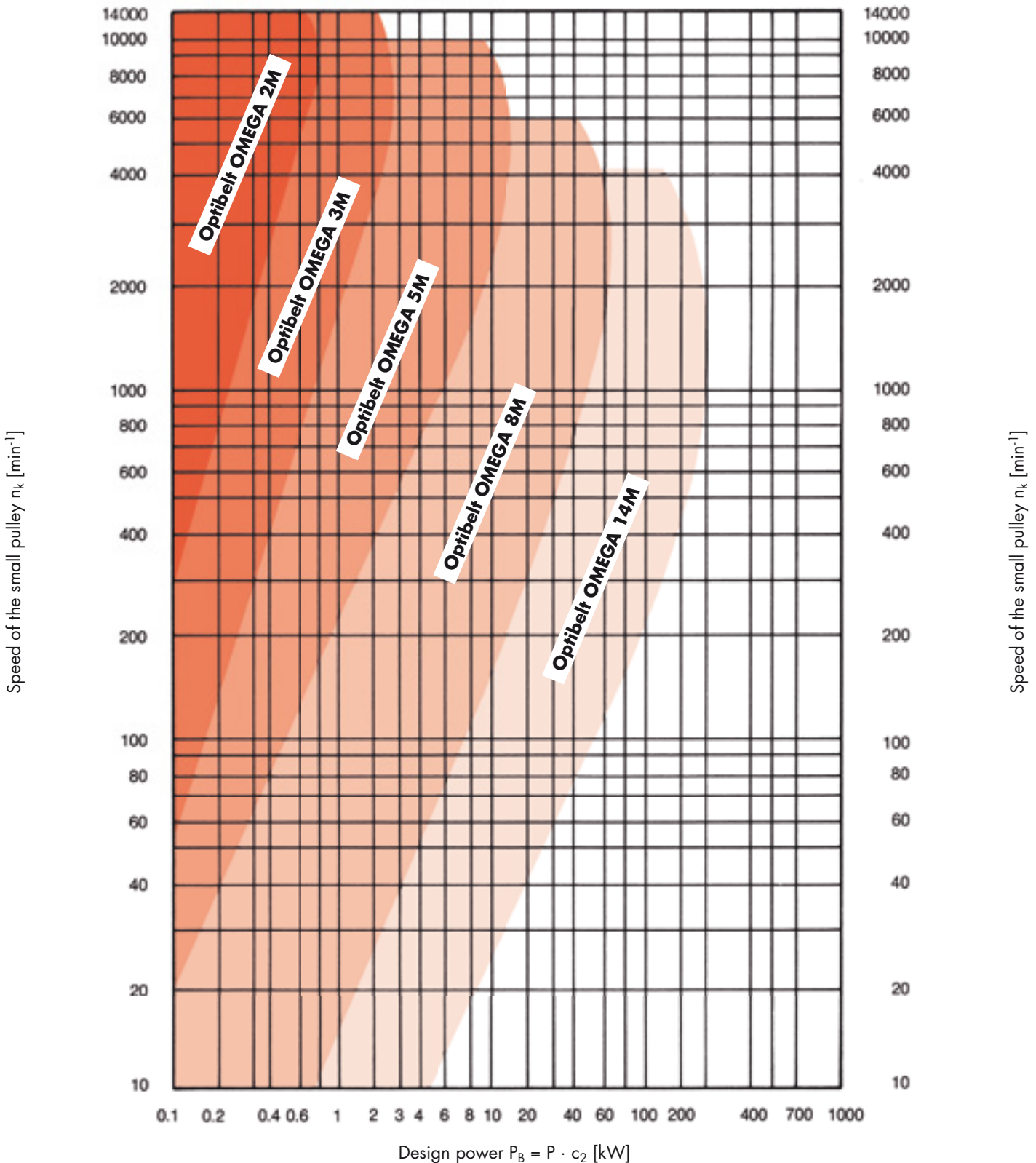

Calculation

Timing Belts with **optibelt OMEGA** Section

Service Factors



Power Transmission

Total service factor c_2

The total service factor c_2 consists of the basic service factor c_0 and two additional factors c_3 and c_6 .

$$c_2 = c_0 + c_3 + c_6$$

$$c_2 \geq M_A/M_N \quad \text{Recommendation for drives with frequent starts and stops}$$

Basic service factor c_0

The basic service factor c_0 takes account of the daily operating time and the type of prime mover and driven machine. Since it is not possible to combine every type of prime mover, driven machine and operating conditions into a single table, the basic service factors should be considered as guide values. The assessment of the driven machine depends on the type of loading on that machine.

Table 1

Basic service factor c_0

Type of loading and examples of driven machines	Type of basic load and examples of prime mover			
	Steady operation Electric motor High speed turbine Piston engine with a large number of cylinders		Intermittent operation Hydraulic motor Low speed turbine Piston engine with a small number of cylinders	
	Basic service factor c_0 during daily operating period			
	until 16 h	more than 16 h	until 16 h	more than 16 h
Light drives, shock free and steady running Measuring devices Film cameras Office machines Belt conveyors (light-weight materials)	1.3	1.4	1.4	1.5
Medium duty drives, intermittent operation with low to medium shock loading Mixers Kitchen appliances Printing machines Textile machines Packaging machines Belt conveyors (heavy materials)	1.6	1.7	1.8	1.9
Heavy duty drives, intermittent operation with medium to high shock loading Machine tools Woodworking machines Eccentric drives Conveyor systems (heavy materials)	1.8	1.9	2.0	2.1
Very heavy duty drives, continuous operation with severe shock loading Mills Calenders Extruders Piston pumps and piston compressors Lifting devices	2.0	2.1	2.2	2.3

Calculation

Timing Belts with **optibelt OMEGA** Section

Supplementary Factors



Power Transmission

Speed correction factor c_3

For speed increasing drives, a factor corresponding to the speed ratio is added to the basic service factor c_0 .

Table 2

Speed ratio i	Speed ratio correction factor c_3
1.00 – 0.80	0.0
0.79 – 0.57	0.1
0.56 – 0.40	0.2
0.39 – 0.28	0.3
0.27 and less	0.4

Table 3

Fatigue correction factor c_6

Operating conditions	Fatigue correction factor c_6
Use of tension or guide idlers	0.2
Operating time 16 to 24 hours	0.2
Only rare/occasional operation	- 0.2

With frequent starts and stops or continual reversing operation, the total service factor c_2 chosen should be higher than the ratio between starting torque and nominal torque. If there is a brake on the prime mover the same procedure should apply for the braking torque, if the brake is used frequently. For further questions, please contact the Optibelt Application Engineering Department.

Minimum adjustment of centre distance x for tensioning of timing belts

$$x = 0.004 \cdot a_{\text{nom}}$$

Table 4

Minimum adjustment of centre distance 'y' for installation on timing pulleys without flanges

Centre distances [mm]	Adjustment for fitting of the timing belt [mm]
until 1000	1.8
from 1000 to 1780	2.8
from 1780 to 2540	3.3
from 2540 to 3300	4.1
from 3300 to 4600	5.3

Table 5

Minimum adjustment of centre distance y for installation on timing pulleys with flanges

Pitch [mm]	Flange on one timing pulley [mm]	Flange on both timing pulleys [mm]
2	6	12
3	8	14
5	14	19
8	22	33
14	36	58

Table 6

Belt length factor c_7

Section 2M		Section 8M	
Pitch length [mm]	c_7	Pitch length [mm]	c_7
≤ 190	0.8	≤ 600	0.8
$> 190 \leq 260$	0.9	$> 600 \leq 880$	0.9
$> 260 \leq 400$	1.0	$> 880 \leq 1200$	1.0
$> 400 \leq 600$	1.1	$> 1200 \leq 1760$	1.1
> 600	1.2	> 1760	1.2
Section 3M		Section 14M	
Pitch length [mm]	c_7	Pitch length [mm]	c_7
≤ 190	0.8	≤ 1190	0.80
$> 190 \leq 260$	0.9	$> 1190 \leq 1610$	0.90
$> 260 \leq 400$	1.0	$> 1610 \leq 1890$	0.95
$> 400 \leq 600$	1.1	$> 1890 \leq 2450$	1.00
> 600	1.2	$> 2450 \leq 3150$	1.05
Section 5M		> 3150	1.10
Pitch length [mm]	c_7		
≤ 440	0.8		
$> 440 \leq 555$	0.9		
$> 555 \leq 800$	1.0		
$> 800 \leq 1100$	1.1		
> 1100	1.2		

Table 7

Teeth in mesh factor c_1

Number of teeth in mesh	Teeth in mesh factor c_1
≥ 6	1.0
5	0.8
4	0.6
3	0.4
2	0.2

Calculation

Timing Belts with **optibelt OMEGA** Section

Formulae and Calculation Example



Power Transmission

Prime mover

Electric motor 50 Hz
 Star/delta start
 $P = 18.5 \text{ kW}$
 $n_1 = 2850 \text{ min}^{-1}$

Operating conditions

Daily operating time: 12 hours
 Number of starts/stops: 2 per day
 Environmental influences:
 ambient room temperature,
 no influence from oil, water or dust
 Centre distance: 400 mm to 450 mm
 Max. pulley diameter: 200 mm

Driven machine

Textile machine
 $P = 15 \text{ kW}$
 $n_2 = 1830 \text{ min}^{-1} \pm 1\%$
 Type of load: constant

see also Optibelt CAP drive
 calculation programme
 software at www.optibelt.com

Formulae

Total service factor

$c_2 = c_0 + c_3 + c_6$
 c_0 from table 1, page 30
 c_3 from table 2, page 31
 c_6 from table 3, page 31

Design power

$P_B = P \cdot c_2$

Selection of timing belt section and construction

from diagrams 1-3, pages 27-29

Speed ratio

$i = \frac{n_1}{n_2} = \frac{z_2}{z_1} = \frac{d_{w2}}{d_{w1}}$

Number of teeth of the pulleys

z_1, d_{w1} selected from standard range of timing belt pulleys
 page 52
 $z_2 = z_1 \cdot i$

Observe the minimum diameter requirement!

Check the driven speed

$i = \frac{z_2}{z_1}$
 $n_2 = \frac{n_1}{i}$

Recommended centre distance

Recommendation:
 $a > 0.5 (d_{w1} + d_{w2}) + 15 \text{ mm}$
 $a < 2.0 (d_{w1} + d_{w2})$

Calculation example

$c_2 = 1.6 + 0 + 0 = \mathbf{1.6}$
 $c_0 = 1.6$
 $c_3 = 0$
 $c_6 = 0$

$P_B = 18.5 \cdot 1.6 = \mathbf{29.6 \text{ kW}}$

Optibelt OMEGA HP timing belt 8M HP

$i = \frac{2850}{1830} = \mathbf{1.557}$

$z_1 = \mathbf{36}$

$d_{w1} = 91.67 \text{ mm}$

$z_2 = 36 \cdot 1.56 = 56.16$

$z_2 = \mathbf{56}$

$d_{w2} = 142.60 \text{ mm}$

z_2 selected from standard range pulleys page 52

Requirement $z_1 \geq 22$ (minimum number of teeth for section 8M)
 complies

$i = \frac{56}{36} = 1.556$

$n_2 = \frac{2850}{1.556} = \mathbf{1832 \text{ min}^{-1}}$

Requirement:
 $\mathbf{1830 \text{ min}^{-1} \pm 1\%}$ fulfilled

$a > 0.5 (91.67 + 142.60) + 15 \text{ mm} = 132.14 \text{ mm}$

$a < 2.0 (91.67 + 142.60) = 468.54 \text{ mm}$

$a = \mathbf{425 \text{ mm}}$ provisionally selected

Calculation

Timing Belts with **optibelt OMEGA** Section

Formulae and Calculation Example



Power Transmission

Formulae

Pitch length of the timing belt

$$L_{wth} \approx 2a + \frac{\pi}{2} (d_{wg} + d_{wk}) + \frac{(d_{wg} - d_{wk})^2}{4a}$$

 L_{wSt} standard lengths, see pages 7-8, 12-15 and 17-21

Centre distance from L_{wSt}

$$a_{nom} = K + \sqrt{K^2 - \frac{(d_{wg} - d_{wk})^2}{8}}$$

$$K = \frac{(L_{wSt})}{4} - \frac{\pi}{8} (d_{wg} + d_{wk})$$

Minimum adjustment of centre distance for tensioning

$$x = 0.004 \cdot a_{nom}$$

Minimum adjustment for fitting belts

 $y =$ from table 5, page 31

Number of teeth in mesh on the small pulley

$$z_e = \frac{z_k}{6} \left(3 - \frac{d_{wg} - d_{wk}}{a_{nom}} \right)$$

Belt length factor

 c_7 from table 6, page 31

Teeth in mesh factor

 c_1 from table 7, page 31

Belt width above nominal power rating

 Requirement: $P_{\ddot{U}} \geq P_B$
 $P_{\ddot{U}}$ = transmissible nominal power of a standard belt width

$$P_{\ddot{U}} = P_N \cdot c_1 \cdot c_7$$

 P_N value and, if required, width correction factor (which is to be multiplied by the P_N value) see pages 36 to 48

Calculation example

$$L_{wth} \approx 2 \cdot 425 + \frac{\pi}{2} (142.60 + 91.67) + \frac{(142.60 - 91.67)^2}{4 \cdot 425}$$

$$L_{wth} \approx \mathbf{1219.33 \text{ mm}}$$

next standard belt length selected from page 18

$$L_{wSt} = \mathbf{1200 \text{ mm}}$$

$$a_{nom} = 208 + \sqrt{208^2 - \frac{(142.60 - 91.67)^2}{8}}$$

$$a_{nom} = \mathbf{415.22 \text{ mm}}$$

$$K = \frac{1200}{4} - \frac{\pi}{8} (142.60 + 91.67) = 208 \text{ mm}$$

$$x \geq \mathbf{1.66 \text{ mm}}$$

$$y = \mathbf{22 \text{ mm}}$$
 (with flanged pulley)

$$z_e = \frac{36}{6} \left(3 - \frac{142.60 - 91.67}{415} \right) = 17.26$$

$$z_e = \mathbf{17}$$

$$c_7 = \mathbf{1.0}$$

$$c_1 = \mathbf{1.0}$$

31.09 kW > 29.60 kW Requirement met!

$$P_{\ddot{U}} = 31.09 \cdot 1.0 \cdot 1.0 = \mathbf{31.09 \text{ kW}}$$

$$P_N \text{ for width of } 30 \text{ mm} = 19.68 \cdot 1.58 = \mathbf{31.09 \text{ kW}}$$

Drive to be fitted with:

1 Optibelt OMEGA HP timing belt	1200 8M HP 30
1 Optibelt ZRS timing belt pulley	36 8M 30
1 Optibelt ZRS timing belt pulley	56 8M 30

Calculation

Timing Belts with **optibelt OMEGA** Section

Belt Tension



Power Transmission

Belt tension for **Optibelt OMEGA HP/Optibelt OMEGA HL** and **Optibelt OMEGA** timing belts

For faultless power transmission and for the achievement of acceptable belt service life, the correct belt tension is of the utmost importance. Too low or too high a belt tension will lead to the premature failure of the timing belts. Over tensioning often leads to bearing failure on the prime mover or the driven machine.

Experience showed that unscientific belt tensioning methods, such as the "thumb pressure method", are not suitable for applying the optimum tension to the drive for maximum efficiency and drive/bearing life. It is therefore recommended that the correct static belt tension should be calculated for each drive.

By virtue of their extremely low-stretch characteristics Optibelt timing belts do not require any further tensioning after correct installation if properly used.

Symbol

F	= test force	[N]
S _α	= static shaft loading	[N]
S _{n3}	= circumferential force to be effectively transmitted	[N]
E _α	= belt deflection for given span length	[mm]
L	= span length	[mm]

Apply test force F in the centre of the span perpendicular to the belt top surface as shown in the illustration below; measure the deflection E_α, correct the tension if necessary.

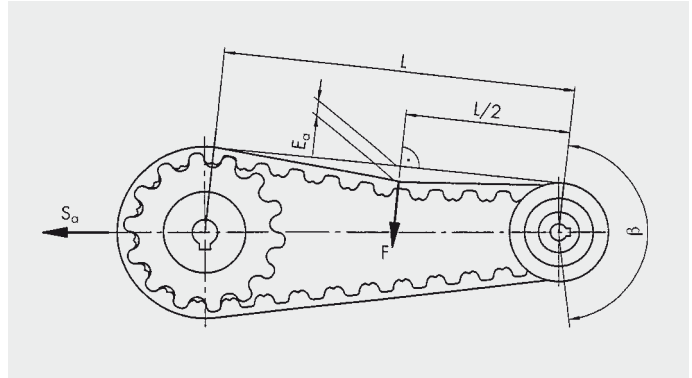

1. Calculation of the test force F

$$F = \frac{S_{n3}}{20}$$

$$S_{n3} = \frac{P \cdot 1000}{v} \quad v = \frac{d_{wk} \cdot n_k}{19100}$$

$$F = \frac{1352}{20} = \mathbf{67.60 \text{ N}}$$

$$S_{n3} = \frac{18.5 \cdot 1000}{13.68} \quad v = \frac{91.67 \cdot 2850}{19100}$$

$$S_{n3} = 1352 \text{ N} \quad v = 13.68 \text{ m/s}$$

2. Calculation of the belt deflection E_α for the existing span length L

$$E_{\alpha} = \frac{L}{50}$$

$$L = \sqrt{a_{nom}^2 - \left(\frac{d_{wg} - d_{wk}}{2}\right)^2}$$

$$E_{\alpha} = \frac{414.44}{50} = \mathbf{8.3 \text{ mm}}$$

$$L = \sqrt{415.22^2 - \left(\frac{142.60 - 91.67}{2}\right)^2} = 414.44 \text{ mm}$$

3. Calculation of the minimum static shaft loading

$$S_{\alpha} = S_{n3} \cdot 1.1$$

$$S_{\alpha} = 1352 \text{ N} \cdot 1.1 = \mathbf{1487.2 \text{ N}}$$

4. Calculation of the frequency for measuring the belt tension using the Optibelt frequency tension tester

$$f = \sqrt{\frac{T}{4 \cdot k \cdot L^2}}$$

$$T = 0.5 \cdot S_{\alpha}$$

k belt weight per metre from table 8, page 49

L span length per metre

$$f = \sqrt{\frac{743.6}{4 \cdot 0.174 \cdot 0.414^2}} = \mathbf{78.9 \text{ Hz}}$$

$$T = 0.5 \cdot 1487.2 \text{ N} = 743.6 \text{ N}$$

$$k = 0.174 \text{ kg/m}$$

$$L = 0.414 \text{ m}$$

Calculation

Timing Belts with **optibelt OMEGA** Section

optibelt CAP Drive Calculation Programme



Power Transmission

The drive is to be equipped with:

- Optibelt OMEGA HP timing belt 1200 8M HP 30
- Optibelt ZRS pulley 36-8M-30 (cylindrical bore)
- Optibelt ZRS pulley 56-8M-30 (cylindrical bore)

see also
Optibelt CAP drive calculation
software at www.optibelt.com

Prime mover	Electric motor P = 18.5 kW	
Driven machine	Textile machine	
<u>Timing belt data</u>		Variations/Information
Pitch	t: 8.000 mm	
Width	b: 30.00 mm	
Calculated pitch length	L _{wth} : 1200.00 mm	
Standard pitch length	L _w : 1200.00 mm	
Number of teeth	Z _r : 150	
Belt speed	v: 13.68 m/s	
<u>Timing pulley data</u>	Pulley 1 (driving)	Pulley 2 (driven)
Number of teeth	z: 36	56
Pitch diameter	d _w : 91.67 mm	142.60 mm
Pulley face width	b ₁ : 38.00 mm	38.00 mm
Speed	n: 2850.0 1/min	1832.1 1/min
Number of teeth in mesh	Z _e : 17	29
Torque	M: 104 Nm	162 Nm
Standard construction	6F	6WF
Number of flanged pulleys	2	2
Material	St	GG
<u>Nominal drive data</u>		Variations/Information
Design power	P_B: 29.60 kW	
Nominal power rating	P _Ü : 31.09 kW	
Effective service factor	c₂: 1.68	
Actual drive ratio	i: 1.56	0.0 %
Actual centre distance	a: 415.22 mm	-9.78 mm
Minimum adjustment of centre distance for belt installation	y: ≥ 22.00 mm	
Minimum adjustment of centre distance for belt tensioning	x: ≥ 1.66 mm	
Actual circumferential load	S _{n3} : 1353 N	
Static shaft load	S _a : 1488 N	
Static span tension	T: 744 N	
Span length	L: 414.50 mm	

Methods for setting belt tension

Belt deflection per span length E_a: 8.29 mm with a load F 67.60 N
 Optibelt TT 3 frequency tension tester f: 78.88 1/s

Power Ratings

optibelt OMEGA HL Timing Belts

Section and Construction 8M HL



Power Transmission

Nominal power P_N [kW] for section and construction 8M HL and timing belt width of 20 mm

Speed of the small pulley n_k [min ⁻¹]	Number of teeth on the small pulley z_k																
	22	24	26	28	30	32	34	36	38	40	44	48	52	56	64	72	80
	Pitch diameter of the small pulley d_{wk} [mm]																
	56.02	61.12	66.21	71.30	76.39	81.49	86.58	91.67	96.77	101.86	112.05	122.23	132.42	142.60	162.97	183.35	203.72
10	0.07	0.08	0.09	0.09	0.11	0.12	0.13	0.14	0.15	0.15	0.18	0.20	0.22	0.24	0.27	0.31	0.34
20	0.13	0.15	0.18	0.19	0.21	0.22	0.25	0.27	0.28	0.31	0.34	0.38	0.41	0.45	0.53	0.60	0.67
50	0.32	0.35	0.40	0.45	0.49	0.54	0.59	0.64	0.67	0.72	0.81	0.90	0.98	1.07	1.25	1.43	1.59
100	0.59	0.68	0.77	0.86	0.94	1.04	1.12	1.20	1.30	1.38	1.56	1.72	1.89	2.06	2.39	2.73	3.06
200	1.12	1.30	1.46	1.63	1.80	1.97	2.13	2.30	2.47	2.64	2.97	3.30	3.62	3.95	4.59	5.24	5.89
300	1.63	1.87	2.12	2.37	2.62	2.86	3.11	3.36	3.61	3.84	4.34	4.82	5.30	5.77	6.73	7.67	8.61
400	2.11	2.44	2.76	3.09	3.42	3.73	4.06	4.38	4.70	5.02	5.67	6.29	6.92	7.55	8.80	10.05	11.28
500	2.58	2.98	3.39	3.79	4.19	4.59	5.00	5.40	5.78	6.19	6.96	7.75	8.53	9.31	10.85	12.37	13.89
600	3.04	3.52	4.01	4.49	4.96	5.43	5.91	6.39	6.86	7.32	8.26	9.19	10.11	11.03	12.85	14.67	16.47
700	3.58	4.16	4.72	5.30	5.87	6.43	6.99	7.55	8.11	8.67	9.78	10.87	11.97	13.07	15.23	17.39	19.52
800	3.95	4.57	5.21	5.83	6.46	7.08	7.71	8.32	8.94	9.55	10.78	11.99	13.20	14.41	16.80	19.17	21.53
1000	4.82	5.60	6.37	7.15	7.93	8.69	9.46	10.23	10.98	11.75	13.25	14.75	16.24	17.72	20.67	23.58	26.46
1200	5.68	6.60	7.53	8.45	9.37	10.27	11.18	12.09	13.00	13.89	15.68	17.45	19.21	20.97	24.45	27.90	31.30
1450	6.76	7.88	8.99	10.10	11.19	12.29	13.38	14.47	15.55	16.62	18.77	20.90	23.01	25.12	29.28	33.39	37.44
1600	7.34	8.55	9.77	10.97	12.17	13.36	14.55	15.73	16.91	18.08	20.42	22.73	25.02	27.31	31.83	36.29	40.69
1800	8.15	9.51	10.86	12.21	13.54	14.87	16.20	17.52	18.83	20.14	22.74	25.32	27.86	30.41	35.43	40.38	45.24
2000	8.94	10.45	11.93	13.42	14.89	16.36	17.83	19.27	20.72	22.16	25.02	27.86	30.66	33.46	38.97	44.38	49.70
2200	9.73	11.37	13.00	14.62	16.22	17.83	19.42	21.01	22.59	24.15	27.27	30.36	33.40	36.44	42.42	48.27	54.00
2400	10.51	12.29	14.06	15.81	17.55	19.29	21.02	22.74	24.45	26.14	29.51	32.85	36.13	39.42	45.87	52.16	58.31
2800	12.04	14.09	16.13	18.14	20.16	22.15	24.14	26.11	28.08	30.02	33.88	37.70	41.45	45.19	52.50	59.60	66.50
3000	12.49	14.62	16.73	18.84	20.92	23.00	25.06	27.11	29.15	31.16	35.18	39.13	43.01	46.89	54.44	61.77	68.86
3500	14.63	17.14	19.64	22.11	24.56	27.00	29.43	31.83	34.21	36.58	41.26	45.87	50.35	54.83	63.48		
4000	16.42	19.25	22.07	24.86	27.63	30.36	33.08	35.78	38.44	41.09	46.30	51.43	56.38	61.34			
4500	18.17	21.31	24.44	27.53	30.60	33.63	36.63	39.60	42.53	45.44	51.16	56.74	62.37				
5000	19.86	23.32	26.74	30.13	33.48	36.79	40.06	43.30	46.49	49.64	55.81	61.81	67.90				
5500	21.51	25.27	28.98	32.66	36.28	39.86	43.38	46.86	50.28	53.67	60.25						

Power ratings for other belt widths can be calculated by multiplying by the width correction factors.

Width correction factor

Section and construction 8M HL

Standard belt width [mm]	20	30	50	85
Factor	1.00	1.58	2.73	4.76

Power Ratings

optibelt OMEGA HL Timing Belts

Section and Construction 14M HL



Power Transmission

Nominal power P_N [kW] for section and construction 14M HL and timing belt width of 40 mm

Speed of the small pulley n_k [min ⁻¹]	Number of teeth on the small pulley z_k																
	28	29	30	32	34	36	38	40	42	44	46	48	52	56	64	72	80
	Pitch diameter of the small pulley d_{wk} [mm]																
	124.78	129.23	133.69	142.6	151.52	160.43	169.34	178.25	187.17	196.08	204.99	213.9	231.73	249.55	285.21	320.86	356.51
10	0.53	0.56	0.59	0.62	0.67	0.72	0.77	0.80	0.85	0.90	0.94	0.99	1.07	1.15	1.32	1.50	1.66
20	1.01	1.05	1.08	1.18	1.27	1.34	1.44	1.52	1.60	1.68	1.77	1.85	2.01	2.18	2.50	2.83	3.13
40	1.87	1.94	2.02	2.19	2.34	2.50	2.66	2.82	2.97	3.13	3.28	3.43	3.74	4.05	4.65	5.25	5.84
60	2.72	2.84	2.96	3.19	3.42	3.65	3.89	4.11	4.34	4.57	4.80	5.02	5.47	5.91	6.81	7.67	8.54
100	4.29	4.48	4.67	5.04	5.42	5.78	6.14	6.52	6.88	7.25	7.60	7.95	8.67	9.38	10.78	12.17	13.55
200	7.94	8.29	8.65	9.34	10.05	10.73	11.42	12.10	12.78	13.47	14.13	14.80	16.14	17.47	20.09	22.67	25.22
300	11.35	11.85	12.35	13.36	14.37	15.36	16.35	17.34	18.32	19.30	20.26	21.23	23.14	25.05	28.81	32.52	36.18
400	14.59	15.25	15.91	17.20	18.50	19.79	21.08	22.34	23.60	24.87	26.12	27.37	29.84	32.31	37.16	41.94	46.64
500	17.71	18.51	19.31	20.90	22.49	24.06	25.63	27.18	28.71	30.24	31.77	33.30	36.30	39.30	45.21	51.01	56.73
600	20.72	21.67	22.62	24.49	26.34	28.21	30.04	31.86	33.67	35.49	37.27	39.04	42.57	46.10	53.01	59.79	66.47
700	24.25	25.35	26.46	28.66	30.86	33.04	35.19	37.32	39.45	41.58	43.67	45.76	49.88	54.01	62.09	70.00	77.77
800	26.54	27.76	28.98	31.39	33.79	36.17	38.54	40.89	43.22	45.54	47.83	50.13	54.64	59.14	67.98	76.62	85.09
950	32.11	33.59	35.07	38.00	40.92	43.80	46.68	49.52	52.34	55.16	57.93	60.70	66.14	71.59	82.20	92.53	102.61
1000	37.45	39.19	40.93	44.36	47.77	51.16	54.51	57.82	61.11	64.40	67.63	70.86	77.17	83.49	95.74	107.59	119.09
1200	44.15	46.20	48.25	52.32	56.34	60.33	64.27	68.18	72.04	75.90	79.67	83.45	90.80	98.15	112.33	125.91	138.93
1450	47.63	49.85	52.06	56.46	60.79	65.09	69.35	73.57	77.71	81.86	85.91	89.97	97.84	105.72	120.79	135.16	148.83
1600	52.48	54.93	57.38	62.21	67.00	71.72	76.40	81.01	85.55	90.10	94.52	98.95	107.51	116.06	132.29	147.61	
1800	57.19	59.86	62.54	67.79	73.00	78.14	83.20	88.21	93.12	98.02	102.80	107.57	116.72	125.86	143.08		
2000	61.70	64.57	67.45	73.12	78.72	84.23	89.66	95.01	100.24	105.47	110.54	115.60	125.24	134.87			
2200	66.20	69.28	72.36	78.44	84.44	90.32	96.12	101.82	107.37	112.92	118.28	123.64	133.76	143.88			
2400	70.44	73.72	76.99	83.43	89.77	95.98	102.09	108.09	113.90	119.71	125.30	130.88					
2600	74.68	78.15	81.62	88.42	95.10	101.64	108.07	114.35	120.43	126.51	132.31	138.12					
2850	77.12	80.70	84.27	91.28	98.15	104.88	111.47	117.90	124.11	130.33	136.23	142.14					
3000	88.30	92.35	96.39	104.27	111.94	119.38	126.62	133.63	66.81								
3500	97.06	101.43	105.80	114.27	122.45												

Power ratings for other belt widths can be calculated by multiplying by the width correction factors.

Width correction factor

Section and construction 14M HL

Standard belt width [mm]	40	55	85	115	170
Factor	1.00	1.44	2.50	3.50	5.32

Power Ratings

optibelt OMEGA FanPower Timing Belts

Section and Construction 8M FP



Power Transmission

Nominal power P_N [kW] for section and construction 8M FP and timing belt width of 20 mm

Speed of the small pulley n_k [min ⁻¹]	Number of teeth on the small pulley z_k																
	22	24	26	28	30	32	34	36	38	40	44	48	52	56	64	72	80
	Pitch diameter of the small pulley d_{wk} [mm]																
	56.02	61.12	66.21	71.30	76.39	81.49	86.58	91.67	96.77	101.86	112.05	122.23	132.42	142.60	162.97	183.35	203.72
10	0.06	0.07	0.08	0.08	0.09	0.10	0.11	0.12	0.13	0.13	0.15	0.17	0.19	0.20	0.24	0.27	0.30
20	0.11	0.13	0.15	0.16	0.18	0.19	0.22	0.24	0.25	0.27	0.30	0.33	0.36	0.39	0.46	0.52	0.58
50	0.28	0.31	0.35	0.39	0.43	0.47	0.51	0.55	0.58	0.62	0.71	0.78	0.86	0.93	1.09	1.24	1.38
100	0.51	0.59	0.67	0.75	0.82	0.90	0.97	1.04	1.13	1.20	1.35	1.50	1.64	1.79	2.08	2.38	2.66
200	0.97	1.13	1.27	1.41	1.57	1.71	1.85	2.00	2.15	2.29	2.58	2.87	3.15	3.43	4.00	4.56	5.12
300	1.41	1.63	1.84	2.06	2.27	2.49	2.70	2.92	3.13	3.34	3.77	4.19	4.61	5.02	5.85	6.67	7.49
400	1.83	2.12	2.40	2.68	2.97	3.25	3.53	3.81	4.09	4.36	4.93	5.47	6.02	6.57	7.65	8.74	9.80
500	2.24	2.59	2.95	3.30	3.65	4.00	4.34	4.69	5.03	5.38	6.05	6.74	7.42	8.09	9.44	10.76	12.08
600	2.64	3.06	3.48	3.90	4.31	4.72	5.14	5.55	5.96	6.36	7.18	7.99	8.79	9.59	11.18	12.76	14.32
700	3.11	3.62	4.11	4.61	5.10	5.59	6.08	6.57	7.05	7.54	8.50	9.46	10.41	11.36	13.25	15.12	16.98
800	3.43	3.98	4.53	5.07	5.61	6.16	6.70	7.23	7.78	8.31	9.37	10.43	11.48	12.53	14.61	16.67	18.72
1000	4.19	4.87	5.54	6.22	6.89	7.56	8.23	8.89	9.55	10.21	11.53	12.83	14.12	15.41	17.97	20.50	23.01
1200	4.94	5.74	6.55	7.35	8.14	8.93	9.72	10.51	11.30	12.08	13.64	15.17	16.70	18.24	21.26	24.26	27.22
1450	5.88	6.85	7.82	8.78	9.73	10.69	11.64	12.58	13.52	14.46	16.32	18.17	20.01	21.84	25.46	29.03	32.56
1600	6.38	7.44	8.49	9.54	10.58	11.62	12.65	13.68	14.70	15.73	17.75	19.76	21.76	23.75	27.68	31.55	35.39
1800	7.09	8.27	9.45	10.61	11.77	12.93	14.09	15.23	16.37	17.51	19.77	22.02	24.23	26.44	30.81	35.11	39.34
2000	7.78	9.09	10.38	11.67	12.95	14.23	15.50	16.76	18.02	19.27	21.76	24.23	26.66	29.10	33.89	38.59	43.21
2200	8.46	9.89	11.30	12.71	14.11	15.50	16.89	18.27	19.64	21.00	23.71	26.40	29.04	31.69	36.89	41.97	46.96
2400	9.14	10.69	12.22	13.75	15.27	16.77	18.28	19.77	21.26	22.73	25.66	28.56	31.42	34.28	39.88	45.35	50.70
2800	10.47	12.25	14.03	15.78	17.53	19.26	20.99	22.70	24.41	26.10	29.46	32.78	36.04	39.30	45.65	51.83	57.82
3000	10.86	12.71	14.55	16.38	18.20	20.00	21.79	23.57	25.35	27.10	30.59	34.02	37.40	40.78	47.34	53.71	59.88
3500	12.72	14.91	17.08	19.23	21.36	23.48	25.59	27.68	29.75	31.81	35.88	39.88	43.78	47.68	55.20		
4000	14.28	16.74	19.19	21.62	24.02	26.40	28.77	31.11	33.43	35.73	40.26	44.72	49.03	53.34			
4500	15.80	18.53	21.25	23.94	26.61	29.24	31.85	34.43	36.98	39.51	44.48	49.34	54.67				
5000	17.27	20.27	23.26	26.20	29.12	32.00	34.83	37.65	40.43	43.16	48.53	53.75	59.87				
5500	18.71	21.98	25.20	28.40	31.54	34.66	37.72	40.74	43.73	46.67	52.39						

Power ratings for other belt widths can be calculated by multiplying by the width correction factors.

Width correction factor

Section and construction 8M FP

Standard belt width [mm]	20	30	50	85
Factor	1.00	1.58	2.73	4.76

Power Ratings

optibelt OMEGA FanPower Timing Belts

Section and Construction 14M FP



Power Transmission

Nominal power P_N [kW] for section and construction 14M FP and timing belt width of 40 mm

Speed of the small pulley n_k [min ⁻¹]	Number of teeth on the small pulley z_k																
	28	29	30	32	34	36	38	40	42	44	46	48	52	56	64	72	80
	Pitch diameter of the small pulley d_{wk} (mm)																
	124.78	129.23	133.69	142.6	151.52	160.43	169.34	178.25	187.17	196.08	204.99	213.9	231.73	249.55	285.21	320.86	356.51
10	0.46	0.49	0.51	0.54	0.58	0.62	0.67	0.70	0.74	0.78	0.82	0.86	0.93	1.00	1.15	1.30	1.44
20	0.88	0.91	0.94	1.02	1.11	1.17	1.25	1.32	1.39	1.47	1.54	1.61	1.75	1.90	2.17	2.46	2.73
40	1.62	1.69	1.76	1.90	2.04	2.17	2.32	2.45	2.58	2.72	2.85	2.99	3.25	3.52	4.05	4.56	5.08
60	2.37	2.47	2.57	2.78	2.97	3.18	3.38	3.58	3.78	3.98	4.17	4.36	4.75	5.14	5.92	6.67	7.43
100	3.73	3.89	4.06	4.38	4.71	5.03	5.34	5.67	5.98	6.30	6.61	6.92	7.54	8.16	9.37	10.58	11.78
200	6.91	7.21	7.52	8.12	8.74	9.33	9.93	10.52	11.12	11.71	12.29	12.87	14.03	15.19	17.47	19.71	21.93
300	9.87	10.30	10.74	11.62	12.50	13.36	14.22	15.08	15.93	16.78	17.62	18.46	20.12	21.78	25.05	28.28	31.46
400	12.68	13.26	13.83	14.96	16.08	17.21	18.33	19.42	20.53	21.63	22.71	23.80	25.95	28.09	32.31	36.47	40.56
500	15.40	16.09	16.79	18.17	19.56	20.92	22.28	23.64	24.97	26.30	27.63	28.95	31.56	34.18	39.31	44.36	49.33
600	18.02	18.85	19.67	21.30	22.91	24.53	26.12	27.70	29.28	30.86	32.40	33.95	37.02	40.09	46.09	51.99	57.80
700	21.08	22.05	23.01	24.93	26.83	28.73	30.60	32.46	34.31	36.15	37.97	39.79	43.38	46.96	53.99	60.87	67.63
800	23.08	24.14	25.20	27.29	29.38	31.45	33.51	35.56	37.58	39.60	41.59	43.59	47.51	51.43	59.11	66.62	73.99
1000	27.92	29.21	30.50	33.04	35.58	38.09	40.59	43.06	45.51	47.97	50.37	52.78	57.52	62.25	71.48	80.46	89.22
1200	32.57	34.08	35.59	38.57	41.54	44.48	47.40	50.28	53.14	56.00	58.81	61.61	67.10	72.60	83.25	93.56	103.56
1450	38.39	40.17	41.95	45.50	48.99	52.46	55.89	59.29	62.64	66.00	69.28	72.57	78.96	85.35	97.68	109.49	120.81
1600	41.42	43.35	45.27	49.09	52.86	56.60	60.30	63.97	67.58	71.18	74.71	78.23	85.08	91.93	105.03	117.53	129.41
1800	45.63	47.76	49.89	54.09	58.26	62.36	66.44	70.44	74.39	78.34	82.20	86.05	93.49	100.92	115.03	128.36	
2000	49.73	52.05	54.38	58.95	63.48	67.94	72.35	76.70	80.97	85.24	89.39	93.54	101.49	109.45	124.42		
2200	53.65	56.15	58.65	63.58	68.45	73.24	77.96	82.62	87.17	91.71	96.12	100.52	108.90	117.28			
2400	57.57	60.25	62.92	68.21	73.43	78.54	83.58	88.54	93.36	98.19	102.85	107.51	116.31	125.11			
2600	61.25	64.10	66.95	72.55	78.06	83.46	88.78	93.99	99.04	104.10	108.95	113.81					
2850	64.94	67.96	70.98	76.89	82.70	88.38	93.98	99.44	104.72	110.01	115.06	120.10					
3000	67.06	70.17	73.28	79.38	85.35	91.20	96.93	102.52	107.93	113.33	118.46	123.60					
3500	76.79	80.30	83.81	90.67	97.34	103.81	110.10	116.20	58.10								
4000	84.40	88.20	92.00	99.37	106.48												
4500	91.28	95.30	99.33														

Power ratings for other belt widths can be calculated by multiplying by the width correction factors.

Width correction factor

Section and construction 14M FP

Standard belt width [mm]	40	55	85	115	170
Factor	1.00	1.44	2.50	3.50	5.32

Power Ratings

optibelt OMEGA HP Timing Belts

Section and Construction 3M HP



Power Transmission

Nominal power P_N [W] for section and construction 3M HP and timing belt width of 9 mm

Speed of the small pulley n_k [min ⁻¹]	Number of teeth on the small pulley z_k														
	10	12	14	16	18	20	24	28	32	40	48	56	64	72	80
	Pitch diameter of the small pulley d_{wk} (mm)														
	9.55	11.46	13.37	15.28	17.19	19.10	22.92	26.74	30.56	38.20	45.84	53.48	61.12	68.75	76.39
20	2.7	3.4	4.1	4.8	5.6	6.4	8.0	9.8	11.5	14.9	18.4	21.6	24.5	27.3	30.0
40	5.2	6.5	7.8	9.2	10.7	12.1	15.2	18.6	21.8	28.5	35.0	41.2	46.7	52.0	57.3
60	7.6	9.5	11.4	13.4	15.5	17.7	22.2	27.0	31.8	41.4	51.0	60.1	68.0	75.8	83.5
100	12.3	15.3	18.4	21.7	25.1	28.7	36.0	43.5	50.9	66.1	81.6	96.3	109.3	122.2	134.7
200	23.3	28.9	34.8	40.9	47.4	54.1	67.7	81.9	95.5	125.0	154.7	183.0	207.1	231.6	255.9
300	31.6	39.4	47.7	56.3	65.6	74.7	93.8	113.6	133.0	173.9	215.1	253.9	287.6	321.9	354.5
400	39.6	49.4	59.7	70.6	82.0	93.3	116.7	141.0	165.6	216.0	268.0	315.6	358.2	400.2	441.5
500	46.3	58.1	70.6	83.6	97.3	111.3	138.6	167.6	197.0	255.8	317.1	372.8	423.0	473.3	521.3
600	52.3	65.6	80.1	95.3	112.1	128.1	160.0	192.4	226.5	294.0	363.6	426.9	485.0	541.8	597.5
700	58.6	73.9	90.0	106.9	125.6	143.7	180.5	217.4	254.7	330.1	407.7	478.8	544.0	607.6	669.7
800	66.1	82.8	100.2	118.6	138.5	158.5	199.2	240.6	281.3	365.0	451.0	529.0	601.0	671.0	739.0
900	71.5	89.0	109.3	129.7	152.0	173.5	217.4	262.8	307.9	399.0	491.0	577.0	655.0	731.0	807.0
950	74.0	92.7	113.3	135.0	157.8	180.8	226.5	273.4	320.6	415.0	512.0	600.0	682.0	761.0	839.0
1000	76.5	96.3	117.4	140.3	164.5	188.1	235.7	284.1	333.2	432.0	531.0	624.0	708.0	791.0	871.0
1200	86.3	109.3	133.7	160.0	187.7	214.8	270.7	326.5	382.2	496.0	609.0	713.0	809.0	902.0	994.0
1400	96.0	122.0	149.7	179.1	211.0	241.7	303.4	366.0	428.2	554.0	680.0	797.0	903.0	1009.0	1110.0
1450	98.5	124.8	153.7	183.6	216.8	247.8	311.9	375.0	439.1	569.0	698.0	818.0	927.0	1034.0	1139.0
1600	106.4	135.2	164.9	197.4	232.5	266.6	335.1	404.3	473.1	611.0	749.0	877.0	995.0	1110.0	1221.0
1800	117.0	148.0	180.0	215.0	253.0	290.0	365.0	440.0	515.0	667.0	816.0	955.0	1082.0	1207.0	1326.0
2000	125.0	158.0	193.0	231.0	272.0	312.0	395.0	475.0	557.0	718.0	879.0	1029.0	1165.0	1298.0	1427.0
2400	141.0	178.0	219.0	263.0	309.0	356.0	450.0	543.0	635.0	819.0	1000.0	1168.0	1322.0	1471.0	1613.0
2850	155.0	198.0	245.0	296.0	350.0	403.0	509.0	614.0	718.0	923.0	1125.0	1313.0	1484.0	1648.0	1792.0
3200	170.0	216.0	266.0	320.0	379.0	436.0	552.0	665.0	779.0	1001.0	1218.0	1419.0	1601.0	1775.0	1940.0
3600	182.0	233.0	287.0	347.0	411.0	473.0	599.0	722.0	845.0	1084.0	1317.0	1531.0	1724.0	1907.0	2079.0
4000	194.0	248.0	308.0	372.0	441.0	508.0	644.0	776.0	907.0	1163.0	1409.0	1635.0	1837.0	2028.0	2203.0
5000	221.0	284.0	352.0	427.0	507.0	587.0	743.0	896.0	1047.0	1335.0	1608.0	1853.0	2065.0	2257.0	2425.0
6000	246.0	317.0	395.0	479.0	571.0	661.0	838.0	1011.0	1178.0	1495.0	1788.0	2045.0	2257.0	2440.0	2587.0
7000	265.0	344.0	429.0	523.0	625.0	724.0	919.0	1105.0	1286.0	1621.0	1919.0	2169.0	2359.0	2506.0	2598.0
8000	284.0	368.0	462.0	564.0	676.0	784.0	994.0	1194.0	1385.0	1733.0	2030.0	2264.0	2420.0	2517.0	2537.0
10000	320.0	418.0	515.0	632.0	759.0	880.0	1114.0	1334.0	1534.0	1877.0	2128.0	2277.0	2393.0		
12000	349.0	452.0	566.0	690.0	822.0	954.0	1204.0	1428.0	1624.0	1920.0	2064.0				
14000	347.0	458.0	583.0	721.0	869.0	1006.0	1260.0	1476.0	1651.0	1856.0					

Power ratings for other belt widths can be calculated by multiplying by the width correction factors.

Width correction factor

Section and construction 3M HP

Belt width [mm]	3	Standard 6	Standard 9	12	Standard 15	20	25
Factor	0.28	0.61	1.00	1.44	1.87	2.63	3.40

Power Ratings

optibelt OMEGA HP Timing Belts

Section and Construction 5M HP



Power Transmission

Nominal power P_N [kW] for section and construction 5M HP and timing belt width of 9 mm															
Speed of the small pulley n_k [min ⁻¹]	Number of teeth on the small pulley z_k														
	14	16	18	20	24	28	32	36	40	44	48	56	64	72	80
	Pitch diameter of the small pulley d_{wk} [mm]														
	22.28	25.46	28.65	31.83	38.20	44.56	50.93	57.30	63.66	70.03	76.39	89.13	101.86	114.59	127.32
700	0.36	0.44	0.53	0.61	0.77	0.93	1.09	1.25	1.43	1.59	1.76	2.09	2.43	2.76	3.09
950	0.45	0.56	0.68	0.78	0.99	1.20	1.40	1.62	1.83	2.05	2.25	2.68	3.09	3.52	3.92
1450	0.62	0.79	0.94	1.09	1.39	1.68	1.98	2.27	2.56	2.85	3.14	3.70	4.26	4.80	5.32
2850	1.04	1.32	1.58	1.83	2.32	2.79	3.27	3.71	4.15	4.59	5.00	5.77	6.49	7.12	7.68
20	0.01	0.02	0.02	0.02	0.03	0.03	0.05	0.06	0.06	0.07	0.07	0.09	0.10	0.12	0.14
40	0.03	0.03	0.05	0.05	0.06	0.08	0.09	0.10	0.12	0.13	0.14	0.17	0.20	0.22	0.25
60	0.05	0.06	0.06	0.07	0.09	0.10	0.13	0.15	0.16	0.18	0.21	0.24	0.28	0.32	0.37
100	0.07	0.08	0.10	0.12	0.14	0.17	0.20	0.23	0.26	0.29	0.32	0.38	0.45	0.51	0.58
200	0.13	0.15	0.18	0.21	0.26	0.31	0.37	0.43	0.48	0.54	0.60	0.71	0.83	0.94	1.07
300	0.17	0.22	0.25	0.30	0.37	0.45	0.53	0.61	0.69	0.77	0.85	1.01	1.18	1.36	1.52
400	0.22	0.28	0.32	0.38	0.47	0.58	0.68	0.78	0.89	0.99	1.09	1.30	1.52	1.74	1.94
500	0.26	0.33	0.39	0.46	0.58	0.70	0.82	0.94	1.07	1.20	1.32	1.58	1.83	2.09	2.35
600	0.31	0.39	0.46	0.53	0.68	0.82	0.95	1.10	1.25	1.39	1.54	1.84	2.14	2.44	2.73
800	0.39	0.49	0.59	0.68	0.86	1.04	1.22	1.40	1.59	1.77	1.96	2.33	2.70	3.07	3.44
900	0.44	0.54	0.64	0.75	0.94	1.15	1.35	1.55	1.75	1.96	2.16	2.56	2.97	3.37	3.77
1000	0.47	0.59	0.70	0.82	1.04	1.25	1.47	1.69	1.91	2.13	2.35	2.78	3.22	3.66	4.08
1200	0.54	0.68	0.82	0.94	1.20	1.45	1.70	1.96	2.21	2.46	2.71	3.21	3.70	4.20	4.67
1400	0.61	0.77	0.92	1.07	1.36	1.63	1.92	2.21	2.50	2.77	3.06	3.61	4.15	4.68	5.20
1600	0.68	0.85	1.02	1.18	1.51	1.82	2.14	2.45	2.76	3.07	3.38	3.98	4.57	5.13	5.68
1800	0.74	0.93	1.12	1.30	1.64	1.99	2.33	2.68	3.01	3.35	3.68	4.32	4.95	5.54	6.12
2000	0.79	1.01	1.22	1.40	1.78	2.16	2.53	2.90	3.25	3.61	3.97	4.65	5.30	5.92	6.51
2400	0.91	1.16	1.39	1.61	2.05	2.47	2.89	3.30	3.70	4.11	4.49	5.22	5.92	6.57	7.15
3200	1.12	1.44	1.71	1.99	2.52	3.02	3.53	4.00	4.47	4.92	5.35	6.14	6.84	7.44	7.95
3600	1.21	1.55	1.86	2.16	2.73	3.28	3.81	4.31	4.80	5.26	5.69	6.47	7.15	7.69	8.12
4000	1.30	1.67	2.00	2.32	2.92	3.51	4.06	4.59	5.08	5.55	5.98	6.75	7.37	7.83	8.14
5000	1.50	1.93	2.31	2.68	3.36	4.00	4.60	5.15	5.65	6.10	6.50	7.13	7.53	7.68	7.58
6000	1.67	2.16	2.59	2.99	3.73	4.39	5.00	5.54	6.01	6.41	6.73	7.12	7.16	6.85	6.19
7000	1.82	2.36	2.82	3.24	4.03	4.70	5.30	5.80	6.20	6.49	6.68	6.73	6.30		
8000	1.94	2.52	3.01	3.46	4.26	4.93	5.47	5.90	6.20	6.36	6.38	5.98			
10000	2.15	2.79	3.32	3.78	4.57	5.14	5.54	5.73	5.72	5.50	5.05				
12000	2.30	2.98	3.52	3.97	4.66	5.08	5.22	5.07	4.62	3.88					
14000	2.39	3.09	3.62	4.04	4.58	4.75	4.55	3.96							

Power ratings for other belt widths can be calculated by multiplying by the width correction factors.

Width correction factor							
Section and construction 5M HP							
Belt width [mm]	6	Standard 9	12	Standard 15	20	Standard 25	30
Factor	0.61	1.00	1.44	1.87	2.63	3.40	4.15

Power Ratings

optibelt **OMEGA HP** Timing Belts

Section and Construction **8M HP**



Power Transmission

Nominal power P_N [kW] for section and construction 8M HP and timing belt width of 20 mm

Speed of the small pulley n_k [min ⁻¹]	Number of teeth on the small pulley z_k																
	22	24	26	28	30	32	34	36	38	40	44	48	52	56	64	72	80
	Pitch diameter of the small pulley d_{wk} [mm]																
	56.02	61.12	66.21	71.30	76.39	81.49	86.58	91.67	96.77	101.86	112.05	122.23	132.42	142.60	162.97	183.35	203.72
10	0.06	0.07	0.08	0.08	0.09	0.10	0.11	0.12	0.13	0.13	0.15	0.17	0.19	0.20	0.24	0.27	0.30
20	0.11	0.13	0.15	0.16	0.18	0.19	0.22	0.24	0.25	0.27	0.30	0.33	0.36	0.39	0.46	0.52	0.58
50	0.28	0.31	0.35	0.39	0.43	0.47	0.51	0.55	0.58	0.62	0.71	0.78	0.86	0.93	1.09	1.24	1.38
100	0.51	0.59	0.67	0.75	0.82	0.90	0.97	1.04	1.13	1.20	1.35	1.50	1.64	1.79	2.08	2.38	2.66
200	0.97	1.13	1.27	1.41	1.57	1.71	1.85	2.00	2.15	2.29	2.58	2.87	3.15	3.43	4.00	4.56	5.12
300	1.41	1.63	1.84	2.06	2.27	2.49	2.70	2.92	3.13	3.34	3.77	4.19	4.61	5.02	5.85	6.67	7.49
400	1.83	2.12	2.40	2.68	2.97	3.25	3.53	3.81	4.09	4.36	4.93	5.47	6.02	6.57	7.65	8.74	9.80
500	2.24	2.59	2.95	3.30	3.65	4.00	4.34	4.69	5.03	5.38	6.05	6.74	7.42	8.09	9.44	10.76	12.08
600	2.64	3.06	3.48	3.90	4.31	4.72	5.14	5.55	5.96	6.36	7.18	7.99	8.79	9.59	11.18	12.76	14.32
700	3.11	3.62	4.11	4.61	5.10	5.59	6.08	6.57	7.05	7.54	8.50	9.46	10.41	11.36	13.25	15.12	16.98
800	3.43	3.98	4.53	5.07	5.61	6.16	6.70	7.23	7.78	8.31	9.37	10.43	11.48	12.53	14.61	16.67	18.72
1000	4.19	4.87	5.54	6.22	6.89	7.56	8.23	8.89	9.55	10.21	11.53	12.83	14.12	15.41	17.97	20.50	23.01
1200	4.94	5.74	6.55	7.35	8.14	8.93	9.72	10.51	11.30	12.08	13.64	15.17	16.70	18.24	21.26	24.26	27.22
1450	5.88	6.85	7.82	8.78	9.73	10.69	11.64	12.58	13.52	14.46	16.32	18.17	20.01	21.84	25.46	29.03	32.56
1600	6.38	7.44	8.49	9.54	10.58	11.62	12.65	13.68	14.70	15.73	17.75	19.76	21.76	23.75	27.68	31.55	35.39
1800	7.09	8.27	9.45	10.61	11.77	12.93	14.09	15.23	16.37	17.51	19.77	22.02	24.23	26.44	30.81	35.11	39.34
2000	7.78	9.09	10.38	11.67	12.95	14.23	15.50	16.76	18.02	19.27	21.76	24.23	26.66	29.10	33.89	38.59	43.21
2200	8.46	9.89	11.30	12.71	14.11	15.50	16.89	18.27	19.64	21.00	23.71	26.40	29.04	31.69	36.89	41.97	46.96
2400	9.14	10.69	12.22	13.75	15.27	16.77	18.28	19.77	21.26	22.73	25.66	28.56	31.42	34.28	39.88	45.35	50.70
2800	10.47	12.25	14.03	15.78	17.53	19.26	20.99	22.70	24.41	26.10	29.46	32.78	36.04	39.30	45.65	51.83	57.82
3000	10.86	12.71	14.55	16.38	18.20	20.00	21.79	23.57	25.35	27.10	30.59	34.02	37.40	40.78	47.34	53.71	59.88
3500	12.72	14.91	17.08	19.23	21.36	23.48	25.59	27.68	29.75	31.81	35.88	39.88	43.78	47.68	55.20		
4000	14.28	16.74	19.19	21.62	24.02	26.40	28.77	31.11	33.43	35.73	40.26	44.72	49.03	53.34			
4500	15.80	18.53	21.25	23.94	26.61	29.24	31.85	34.43	36.98	39.51	44.48	49.34	54.67				
5000	17.27	20.27	23.26	26.20	29.12	32.00	34.83	37.65	40.43	43.16	48.53	53.75	59.87				
5500	18.71	21.98	25.20	28.40	31.54	34.66	37.72	40.74	43.73	46.67	52.39						

New power ratings

Power ratings for other belt widths can be calculated by multiplying by the width correction factors.

Width correction factor

Section and construction **8M HP**

Standard belt width [mm]	20	30	50	85
Factor	1.00	1.58	2.73	4.76

Power Ratings

optibelt OMEGA HP Timing Belts

Section and Construction 14M HP



Nominal power P_N [kW] for section and construction 14M HP and timing belt width of 40 mm

Speed of the small pulley n_k [min ⁻¹]	Number of teeth on the small pulley z_k																
	28	29	30	32	34	36	38	40	42	44	46	48	52	56	64	72	80
	Pitch diameter of the small pulley d_{wk} [mm]																
	124.78	129.23	133.69	142.6	151.52	160.43	169.34	178.25	187.17	196.08	204.99	213.9	231.73	249.55	285.21	320.86	356.51
10	0.46	0.49	0.51	0.54	0.58	0.62	0.67	0.70	0.74	0.78	0.82	0.86	0.93	1.00	1.15	1.30	1.44
20	0.88	0.91	0.94	1.02	1.11	1.17	1.25	1.32	1.39	1.47	1.54	1.61	1.75	1.90	2.17	2.46	2.73
40	1.62	1.69	1.76	1.90	2.04	2.17	2.32	2.45	2.58	2.72	2.85	2.99	3.25	3.52	4.05	4.56	5.08
60	2.37	2.47	2.57	2.78	2.97	3.18	3.38	3.58	3.78	3.98	4.17	4.36	4.75	5.14	5.92	6.67	7.43
100	3.73	3.89	4.06	4.38	4.71	5.03	5.34	5.67	5.98	6.30	6.61	6.92	7.54	8.16	9.37	10.58	11.78
200	6.91	7.21	7.52	8.12	8.74	9.33	9.93	10.52	11.12	11.71	12.29	12.87	14.03	15.19	17.47	19.71	21.93
300	9.87	10.30	10.74	11.62	12.50	13.36	14.22	15.08	15.93	16.78	17.62	18.46	20.12	21.78	25.05	28.28	31.46
400	12.68	13.26	13.83	14.96	16.08	17.21	18.33	19.42	20.53	21.63	22.71	23.80	25.95	28.09	32.31	36.47	40.56
500	15.40	16.09	16.79	18.17	19.56	20.92	22.28	23.64	24.97	26.30	27.63	28.95	31.56	34.18	39.31	44.36	49.33
600	18.02	18.85	19.67	21.30	22.91	24.53	26.12	27.70	29.28	30.86	32.40	33.95	37.02	40.09	46.09	51.99	57.80
700	21.08	22.05	23.01	24.93	26.83	28.73	30.60	32.46	34.31	36.15	37.97	39.79	43.38	46.96	53.99	60.87	67.63
800	23.08	24.14	25.20	27.29	29.38	31.45	33.51	35.56	37.58	39.60	41.59	43.59	47.51	51.43	59.11	66.62	73.99
1000	27.92	29.21	30.50	33.04	35.58	38.09	40.59	43.06	45.51	47.97	50.37	52.78	57.52	62.25	71.48	80.46	89.22
1200	32.57	34.08	35.59	38.57	41.54	44.48	47.40	50.28	53.14	56.00	58.81	61.61	67.10	72.60	83.25	93.56	103.56
1450	38.39	40.17	41.95	45.50	48.99	52.46	55.89	59.29	62.64	66.00	69.28	72.57	78.96	85.35	97.68	109.49	120.81
1600	41.42	43.35	45.27	49.09	52.86	56.60	60.30	63.97	67.58	71.18	74.71	78.23	85.08	91.93	105.03	117.53	129.41
1800	45.63	47.76	49.89	54.09	58.26	62.36	66.44	70.44	74.39	78.34	82.20	86.05	93.49	100.92	115.03	128.36	
2000	49.73	52.05	54.38	58.95	63.48	67.94	72.35	76.70	80.97	85.24	89.39	93.54	101.49	109.45	124.42		
2200	53.65	56.15	58.65	63.58	68.45	73.24	77.96	82.62	87.17	91.71	96.12	100.52	108.90	117.28			
2400	57.57	60.25	62.92	68.21	73.43	78.54	83.58	88.54	93.36	98.19	102.85	107.51	116.31	125.11			
2600	61.25	64.10	66.95	72.55	78.06	83.46	88.78	93.99	99.04	104.10	108.95	113.81					
2850	64.94	67.96	70.98	76.89	82.70	88.38	93.98	99.44	104.72	110.01	115.06	120.10					
3000	67.06	70.17	73.28	79.38	85.35	91.20	96.93	102.52	107.93	113.33	118.46	123.60					
3500	76.79	80.30	83.81	90.67	97.34	103.81	110.10	116.20	58.10								
4000	84.40	88.20	92.00	99.37	106.48												
4500	91.28	95.30	99.33														

New power ratings

Power ratings for other belt widths can be calculated by multiplying by the width correction factors.

Width correction factor

Section and construction 14M HP

Standard belt width [mm]	40	55	85	115	170
Factor	1.00	1.44	2.50	3.50	5.32

Power Ratings

optibelt OMEGA Timing Belts

Section and Construction 2M



Power Transmission

Nominal power P_N [W] for section and construction 2M and timing belt width of 9 mm

Speed of the small pulley n_k [min ⁻¹]	Number of teeth on the small pulley z_k															
	10	12	14	16	18	20	24	28	32	36	40	48	56	64	72	80
	Pitch diameter of the small pulley d_{wk} [mm]															
	6.37	7.64	8.91	10.19	11.46	12.73	15.28	17.83	20.37	22.92	25.46	30.56	35.65	40.74	45.84	50.93
20	0.39	0.48	0.57	0.66	0.75	0.85	1.03	1.23	1.42	1.62	1.82	2.21	2.62	3.02	3.43	3.84
40	0.79	0.96	1.14	1.33	1.52	1.71	2.08	2.46	2.85	3.24	3.63	4.42	5.22	6.02	6.82	7.64
60	1.18	1.44	1.72	1.99	2.27	2.55	3.10	3.67	4.25	4.82	5.41	6.58	7.76	8.96	10.16	11.37
100	1.97	2.41	2.85	3.30	3.75	4.21	5.13	6.07	7.02	7.97	8.93	10.88	12.86	14.80	16.77	18.72
200	3.90	4.75	5.63	6.52	7.41	8.31	10.11	11.96	13.83	15.70	17.57	21.36	25.22	29.07	32.94	36.94
300	5.78	7.07	8.37	9.68	11.02	12.38	15.09	17.79	20.55	23.35	26.13	31.75	37.47	43.23	48.99	54.83
400	7.67	9.36	11.12	12.79	14.56	16.34	19.93	23.57	27.20	30.83	34.51	42.03	49.60	57.17	64.82	72.61
500	9.53	11.64	13.72	15.91	18.10	20.29	24.71	29.24	33.80	38.37	42.96	52.26	61.62	71.10	80.63	90.16
600	11.42	13.93	16.43	19.04	21.64	24.24	29.55	34.95	40.35	45.79	51.30	62.42	73.63	84.92	96.34	107.70
700	13.24	16.16	19.08	22.10	25.12	28.16	34.32	40.58	46.86	53.45	59.93	72.50	85.53	98.65	111.87	125.12
800	15.10	18.40	21.70	25.20	28.60	32.10	39.10	46.20	53.40	61.10	68.60	82.60	97.40	112.40	127.40	142.50
900	16.90	20.60	24.40	28.20	32.10	36.00	43.80	51.80	59.80	68.20	76.40	92.60	109.20	126.00	142.90	159.80
950	17.80	21.70	25.70	29.70	33.80	37.90	46.20	54.60	63.00	71.70	80.30	97.60	115.10	132.80	150.60	168.50
1000	18.70	22.90	27.00	31.20	35.60	39.90	48.50	57.40	66.30	75.20	84.30	102.60	121.00	139.60	158.30	177.10
1200	22.30	27.20	32.20	37.30	42.40	47.50	57.90	68.40	79.00	89.80	100.60	122.40	144.40	166.60	189.00	211.50
1400	25.90	31.60	37.40	43.30	49.20	55.20	67.30	79.50	91.80	104.30	116.80	142.20	167.80	193.60	219.50	245.60
1450	26.80	32.70	38.70	44.80	50.90	57.10	69.60	82.20	95.00	107.90	120.80	147.10	173.60	200.30	227.10	254.10
1600	29.40	36.00	42.50	49.20	55.90	62.80	76.60	90.50	104.50	118.70	133.00	161.90	190.90	220.40	249.90	279.60
1800	32.90	40.30	47.70	55.20	62.80	70.40	85.70	101.40	117.10	133.00	149.10	181.40	214.00	247.00	280.10	313.50
2000	36.50	44.60	52.80	61.00	69.40	77.90	95.00	112.30	129.70	147.30	165.10	200.90	237.00	273.50	310.20	347.20
2400	43.50	53.20	62.90	72.80	82.80	92.90	113.20	133.80	154.60	175.70	196.80	239.60	282.70	326.30	370.10	414.20
2850	51.30	62.70	74.20	85.90	98.00	109.80	133.60	158.00	182.50	207.40	232.40	282.90	333.80	385.20	436.90	489.00
3200	57.40	70.10	82.90	96.10	112.10	124.00	149.40	176.60	204.10	231.90	259.80	316.30	373.30	430.80	488.70	546.90
3600	64.20	78.50	92.90	107.50	122.20	137.20	167.30	197.80	228.60	259.60	291.00	354.30	418.10	482.60	547.40	612.60
4000	71.00	86.80	102.80	118.90	135.20	151.80	185.10	218.80	252.90	287.30	322.00	392.10	462.70	534.00	605.80	678.10
5000	87.90	107.40	127.20	147.10	167.50	187.90	229.10	270.70	313.00	355.80	398.80	485.70	573.10	661.70	750.50	840.20
6000	104.50	127.70	151.30	175.00	199.20	223.50	272.60	322.40	372.70	423.40	474.60	578.10	682.30	787.70	893.60	1000.40
7000	120.80	147.60	174.90	202.40	230.30	258.50	315.40	373.00	431.20	489.90	549.20	669.00	789.60	911.70	1034.40	1158.10
8000	137.10	167.50	198.50	229.80	261.40	293.50	358.10	423.50	489.70	556.40	623.80	759.90	897.00	1035.70	1175.20	1315.70
10000	169.00	206.00	245.00	283.00	322.00	362.00	442.00	522.00	604.00	687.00	770.00	938.00	1107.00	1279.00	1451.00	1625.00
12000	200.00	245.00	290.00	336.00	382.00	429.00	524.00	619.00	716.00	814.00	913.00	1113.00	1314.00	1517.00	1722.00	1928.00
14000	230.00	282.00	334.00	387.00	440.00	494.00	604.00	714.00	826.00	939.00	1053.00	1284.00	1516.00	1692.00	1751.00	1988.00

Power ratings for other belt widths can be calculated by multiplying by the width correction factors.

Width correction factor

Section and construction 2M

Belt width [mm]	Standard 3	Standard 6	Standard 9	12
Factor	0.28	0.61	1.00	1.44

Power Ratings

optibelt OMEGA Timing Belts

Section and Construction 3M



Power Transmission

Nominal power P_N [W] for section and construction 3M and timing belt width of 9 mm

Speed of the small pulley n_k [min ⁻¹]	Number of teeth on the small pulley z_k														
	10	12	14	16	18	20	24	28	32	40	48	56	64	72	80
	Pitch diameter of the small pulley d_{wk} [mm]														
	9.55	11.46	13.37	15.28	17.19	19.10	22.92	26.74	30.56	38.20	45.84	53.48	61.12	68.75	76.39
20	1.6	1.6	1.6	1.6	3.2	3.2	3.2	4.8	4.8	6.4	9.6	11.2	12.8	12.8	14.4
40	3.2	3.2	3.2	4.8	4.8	4.8	6.4	8.0	9.6	14.4	17.6	20.9	24.1	27.3	31.0
60	3.2	4.8	4.8	6.4	8.0	8.0	11.2	12.8	16.0	20.9	27.3	32.6	37.4	40.6	45.5
100	6.4	8.0	9.6	11.2	12.8	14.4	17.6	20.9	25.7	34.2	45.5	53.5	62.0	68.4	76.5
200	12.8	16.0	17.6	20.9	24.1	27.3	35.8	43.9	51.9	70.1	89.8	107.5	122.5	136.9	153.5
300	17.6	20.9	25.7	29.4	34.2	39.0	48.7	58.8	70.1	94.7	120.9	142.2	163.1	182.9	204.3
400	20.9	25.7	31.0	37.4	42.2	48.7	60.4	73.3	86.6	116.0	147.1	174.9	199.5	225.7	249.7
500	25.7	31.0	37.4	43.9	50.3	57.2	71.7	86.6	101.1	135.3	173.3	204.3	233.7	263.1	292.5
600	29.4	35.8	43.9	50.3	57.2	65.2	81.3	97.9	116.0	155.1	196.3	232.1	266.3	298.9	331.6
700	32.6	40.6	48.7	57.2	65.2	73.3	91.4	110.7	130.5	173.3	218.7	259.9	295.7	333.2	371.1
800	37.4	45.5	53.5	63.6	71.7	81.3	101.1	122.5	143.9	190.9	241.7	284.5	325.1	366.3	407.0
900	40.6	48.7	58.8	68.4	78.1	89.8	110.7	133.7	156.7	207.5	261.5	309.1	352.9	397.3	441.2
950	42.2	51.9	62.0	71.7	81.3	93.0	116.0	138.5	163.1	215.5	272.7	321.9	367.9	413.4	459.4
1000	43.9	53.5	63.6	74.9	85.0	96.3	119.3	143.9	170.1	223.5	282.9	333.2	380.7	428.3	475.4
1200	50.3	62.0	73.3	85.0	97.9	110.7	136.9	164.7	194.1	255.1	321.9	379.1	433.2	487.2	539.6
1400	57.2	70.1	82.9	96.3	110.7	124.1	153.5	184.5	217.1	286.1	357.8	421.9	482.4	541.2	601.6
1450	58.8	71.7	85.0	99.5	112.8	127.3	158.3	189.3	223.5	292.5	367.9	431.6	493.6	554.0	616.0
1600	63.6	76.5	91.4	105.9	122.5	136.9	170.1	204.3	240.1	313.9	394.1	462.6	527.8	593.6	658.8
1800	68.4	85.0	101.1	117.6	133.7	150.3	186.1	221.9	261.5	341.7	426.7	501.6	573.8	643.9	714.4
2000	74.9	91.4	109.1	125.7	145.5	163.1	201.1	241.7	282.9	369.5	459.4	541.2	616.0	691.4	766.8
2400	86.0	106.0	126.0	145.0	167.0	188.0	231.0	277.0	323.0	421.0	523.0	614.0	700.0	785.0	869.0
2850	98.0	119.0	141.0	163.0	186.0	211.0	259.0	309.0	362.0	470.0	582.0	682.0	777.0	869.0	961.0
3200	108.0	132.0	157.0	182.0	206.0	232.0	286.0	342.0	398.0	516.0	637.0	746.0	847.0	947.0	1046.0
3600	119.0	144.0	172.0	198.0	226.0	254.0	313.0	372.0	434.0	560.0	690.0	806.0	915.0	1020.0	1123.0
4000	129.0	157.0	185.0	214.0	245.0	275.0	337.0	401.0	467.0	603.0	739.0	862.0	977.0	1087.0	1192.0
5000	154.0	186.0	219.0	254.0	290.0	324.0	398.0	472.0	547.0	700.0	854.0	988.0	1111.0	1228.0	1334.0
6000	177.0	214.0	252.0	291.0	331.0	372.0	454.0	536.0	619.0	788.0	952.0	1093.0	1218.0	1331.0	1428.0
7000	198.0	241.0	283.0	327.0	372.0	416.0	506.0	596.0	687.0	865.0	1034.0	1177.0	1295.0	1393.0	1469.0
8000	219.0	267.0	313.0	362.0	409.0	457.0	555.0	652.0	747.0	933.0	1103.0	1236.0	1338.0	1411.0	1451.0
10000	260.0	314.0	370.0	424.0	480.0	534.0	644.0	749.0	851.0	1034.0	1187.0	1280.0	1318.0	1298.0	1211.0
12000	298.0	360.0	421.0	483.0	544.0	603.0	718.0	828.0	928.0	1092.0	1195.0	1211.0	1133.0		
14000	334.0	401.0	469.0	536.0	600.0	662.0	780.0	887.0	977.0	1098.0	1120.0	1010.0			

Power ratings for other belt widths can be calculated by multiplying by the width correction factors.

Width correction factor

Section and construction 3M

Belt width [mm]	3	Standard 6	Standard 9	12	Standard 15	20	25
Factor	0.28	0.61	1.00	1.44	1.87	2.63	3.40

Power Ratings

optibelt OMEGA Timing Belts

Section and Construction 5M



Power Transmission

Nominal power P_N [W] for section and construction 5M and timing belt width of 9 mm

Speed of the small pulley n_k [min ⁻¹]	Number of teeth on the small pulley z_k														
	14	16	18	20	24	28	32	36	40	44	48	56	64	72	80
	Pitch diameter of the small pulley d_{wk} [mm]														
	22.28	25.46	28.65	31.83	38.20	44.56	50.93	57.30	63.66	70.03	76.39	89.13	101.86	114.59	127.32
20	3.7	4.9	5.8	6.9	8.9	11.0	13.0	15.0	17.0	19.9	22.8	26.8	30.8	34.0	38.0
40	8.9	11.0	11.8	13.8	17.9	21.0	25.9	30.0	34.9	40.1	45.0	53.9	61.1	68.9	76.9
60	13.0	15.9	17.9	21.0	25.9	32.0	38.0	45.0	51.9	59.9	68.0	80.1	91.9	103.2	115.0
100	21.9	25.9	30.0	34.9	44.1	53.9	64.0	74.9	87.0	100.0	113.0	134.3	153.3	172.3	192.2
200	45.0	53.0	61.1	68.9	88.2	107.2	128.2	150.1	174.4	199.4	226.2	268.6	306.6	345.5	383.9
300	61.0	72.0	83.0	94.0	119.0	145.0	172.0	202.0	233.0	266.0	300.0	356.0	407.0	458.0	509.0
400	76.0	90.0	103.0	117.0	147.0	179.0	213.0	249.0	286.0	326.0	368.0	436.0	498.0	561.0	623.0
500	91.0	106.0	122.0	139.0	174.0	211.0	251.0	292.0	336.0	382.0	430.0	510.0	583.0	656.0	728.0
600	104.0	122.0	140.0	159.0	199.0	241.0	286.0	334.0	383.0	435.0	489.0	580.0	662.0	745.0	827.0
700	117.0	137.0	158.0	179.0	223.0	271.0	321.0	373.0	428.0	485.0	545.0	646.0	738.0	829.0	921.0
800	130.0	152.0	174.0	198.0	247.0	299.0	353.0	411.0	471.0	533.0	598.0	709.0	809.0	910.0	1010.0
900	142.0	166.0	191.0	216.0	269.0	326.0	385.0	447.0	512.0	580.0	650.0	769.0	879.0	987.0	1096.0
950	148.0	173.0	199.0	225.0	280.0	339.0	401.0	465.0	532.0	603.0	675.0	799.0	912.0	1025.0	1137.0
1000	154.0	180.0	206.0	234.0	291.0	352.0	416.0	483.0	552.0	625.0	699.0	828.0	945.0	1062.0	1178.0
1200	177.0	207.0	237.0	268.0	334.0	403.0	475.0	551.0	629.0	710.0	794.0	939.0	1072.0	1204.0	1334.0
1400	199.0	232.0	266.0	301.0	375.0	451.0	532.0	615.0	702.0	791.0	884.0	1044.0	1191.0	1336.0	1480.0
1450	205.0	239.0	274.0	309.0	384.0	463.0	545.0	631.0	720.0	811.0	905.0	1070.0	1220.0	1368.0	1515.0
1600	221.0	257.0	295.0	333.0	414.0	498.0	586.0	677.0	771.0	869.0	969.0	1144.0	1303.0	1461.0	1617.0
1800	242.0	281.0	322.0	364.0	451.0	543.0	638.0	736.0	838.0	943.0	1050.0	1239.0	1410.0	1578.0	1745.0
2000	262.0	305.0	349.0	394.0	488.0	586.0	688.0	794.0	902.0	1014.0	1128.0	1329.0	1511.0	1689.0	1864.0
2400	301.0	350.0	400.0	451.0	558.0	669.0	784.0	902.0	1024.0	1148.0	1274.0	1497.0	1697.0	1891.0	2079.0
2850	338.0	393.0	449.0	506.0	625.0	748.0	874.0	1004.0	1137.0	1272.0	1408.0	1649.0	1863.0	2067.0	2262.0
3200	374.0	434.0	496.0	559.0	688.0	822.0	960.0	1100.0	1242.0	1386.0	1531.0	1786.0	2008.0	2217.0	2411.0
3600	409.0	474.0	541.0	609.0	749.0	893.0	1040.0	1190.0	1340.0	1492.0	1644.0	1908.0	2134.0	2340.0	2526.0
4000	443.0	513.0	585.0	658.0	808.0	961.0	1116.0	1274.0	1431.0	1589.0	1745.0	2015.0	2238.0	2436.0	2604.0
5000	523.0	605.0	688.0	772.0	943.0	1115.0	1288.0	1459.0	1628.0	1792.0	1951.0	2212.0	2402.0	2541.0	2623.0
6000	598.0	690.0	783.0	877.0	1064.0	1250.0	1433.0	1610.0	1778.0	1937.0	2084.0	2301.0	2411.0	2434.0	2358.0
7000	669.0	769.0	870.0	971.0	1171.0	1365.0	1550.0	1722.0	1880.0	2019.0	2137.0	2268.0	2245.0		
8000	735.0	843.0	950.0	1057.0	1264.0	1459.0	1637.0	1794.0	1927.0	2031.0	2101.0	2100.0			
10000	854.0	972.0	1088.0	1199.0	1403.0	1577.0	1714.0	1804.0	1842.0	1819.0	1729.0				
12000	956.0	1078.0	1193.0	1299.0	1476.0	1594.0	1643.0	1609.0							
14000	1039.0	1158.0	1264.0	1354.0	1473.0	1495.0	1403.0								

Power ratings for other belt widths can be calculated by multiplying by the width correction factors.

Width correction factor

Section and construction 5M

Belt width [mm]	6	Standard 9	12	Standard 15	20	Standard 25	30
Factor	0.61	1.00	1.44	1.87	2.63	3.40	4.15

Power Ratings

optibelt OMEGA Timing Belts

Section and Construction 8M



Power Transmission

Nominal power P_N [kW] for section and construction 8M and timing belt width of 20 mm

Speed of the small pulley n_k [min ⁻¹]	Number of teeth on the small pulley z_k																
	22	24	26	28	30	32	34	36	38	40	44	48	52	56	64	72	80
	Pitch diameter of the small pulley d_{wk} [mm]																
	56.02	61.12	66.21	71.30	76.39	81.49	86.58	91.67	96.77	101.86	112.05	122.23	132.42	142.60	162.97	183.35	203.72
10	0.015	0.018	0.022	0.026	0.029	0.036	0.042	0.046	0.053	0.057	0.061	0.068	0.072	0.078	0.087	0.097	0.106
20	0.033	0.037	0.044	0.051	0.062	0.072	0.082	0.093	0.106	0.114	0.125	0.135	0.144	0.154	0.173	0.194	0.213
50	0.081	0.092	0.110	0.132	0.154	0.179	0.207	0.234	0.262	0.283	0.310	0.336	0.361	0.386	0.435	0.483	0.532
100	0.165	0.183	0.223	0.264	0.311	0.359	0.412	0.466	0.526	0.566	0.621	0.671	0.722	0.770	0.870	0.967	1.064
200	0.326	0.370	0.447	0.531	0.623	0.720	0.823	0.933	1.051	1.131	1.239	1.340	1.442	1.541	1.739	1.933	2.125
300	0.491	0.535	0.645	0.766	0.897	1.040	1.190	1.340	1.510	1.640	1.780	1.930	2.070	2.220	2.500	2.770	3.050
400	0.652	0.711	0.839	0.993	1.165	1.340	1.540	1.740	1.960	2.120	2.310	2.500	2.680	2.870	3.230	3.590	3.940
500	0.810	0.890	1.020	1.220	1.420	1.640	1.880	2.130	2.390	2.590	2.820	3.050	3.270	3.500	3.940	4.370	4.800
600	0.980	1.070	1.210	1.430	1.670	1.930	2.210	2.510	2.820	3.050	3.320	3.590	3.850	4.110	4.630	5.130	5.630
700	1.140	1.240	1.380	1.640	1.920	2.220	2.540	2.880	3.230	3.500	3.810	4.110	4.410	4.710	5.300	5.870	6.440
800	1.300	1.420	1.560	1.850	2.170	2.500	2.860	3.240	3.640	3.940	4.280	4.630	4.970	5.300	5.960	6.600	7.230
950	1.550	1.690	1.830	2.160	2.520	2.910	3.330	3.770	4.240	4.580	4.990	5.380	5.770	6.160	6.910	7.650	8.370
1000	1.630	1.770	1.930	2.260	2.640	3.050	3.480	3.950	4.440	4.800	5.220	5.630	6.040	6.440	7.230	7.990	8.740
1200	1.950	2.130	2.310	2.650	3.100	3.580	4.090	4.630	5.210	5.630	6.120	6.600	7.070	7.540	8.440	9.320	10.170
1450	2.350	2.570	2.790	3.130	3.660	4.230	4.830	5.470	6.140	6.640	7.210	7.770	8.310	8.850	9.890	10.900	11.850
1600	2.590	2.830	3.070	3.420	3.990	4.610	5.260	5.960	6.690	7.230	7.840	8.440	9.030	9.610	10.730	11.790	12.800
1800	2.920	3.180	3.450	3.780	4.420	5.100	5.820	6.590	7.400	7.990	8.670	9.320	9.960	10.590	11.790	12.920	13.990
2000	3.230	3.520	3.820	4.180	4.840	5.580	6.370	7.210	8.090	8.740	9.470	10.170	10.860	11.530	12.800	13.990	15.090
2200	3.550	3.870	4.190	4.590	5.250	6.050	6.910	7.820	8.770	9.470	10.240	11.000	11.730	12.430	13.760	14.980	16.090
2500	4.020	4.380	4.750	5.190	5.840	6.740	7.690	8.690	9.750	10.520	11.360	12.180	12.950	13.700	15.090	16.320	17.400
2850	4.570	4.970	5.380	5.880	6.510	7.510	8.560	9.670	10.850	11.690	12.600	13.470	14.290	15.060	16.460	17.650	18.620
3000	4.800	5.220	5.650	6.170	6.790	7.820	8.920	10.080	11.300	12.180	13.110	13.990	14.820	15.600	16.990	18.140	19.040
3500					7.720	8.840	10.070	11.370	12.730	13.700	14.680	15.600	16.440	17.200	18.470	19.380	19.890
4000						9.780	11.130	12.550	14.040	15.090	16.090	16.990	17.790	18.470			
4500							12.090	13.620	15.230	16.320	17.300	18.140	18.840				
5000								14.580	16.270	17.400	18.310	19.040	19.570				
5500									17.170	18.310	19.100						
6000										17.910	19.040	19.650					

Power ratings for other belt widths can be calculated by multiplying by the width correction factors.

Width correction factor

Section and construction 8M

Standard belt width [mm]	20	30	50	85
Factor	1.00	1.58	2.73	4.74

Power Ratings

optibelt OMEGA Timing Belts

Section and Construction 14M



Power Transmission

Nominal power P_N [kW] for section and construction 14M and timing belt width of 40 mm

Speed of the small pulley n_k [min ⁻¹]	Number of teeth on the small pulley z_k																
	28	29	30	32	34	36	38	40	42	44	46	48	52	56	64	72	80
	Pitch diameter of the small pulley d_{wk} [mm]																
	124.78	129.23	133.69	142.60	151.52	160.43	169.34	178.25	187.17	196.08	204.99	213.90	231.73	249.55	285.21	320.86	356.51
10	0.17	0.20	0.20	0.23	0.29	0.30	0.34	0.36	0.38	0.40	0.42	0.44	0.49	0.53	0.61	0.68	0.74
20	0.35	0.37	0.43	0.49	0.55	0.63	0.68	0.72	0.76	0.80	0.83	0.89	0.97	1.04	1.19	1.34	1.50
40	0.72	0.78	0.84	0.98	1.10	1.25	1.34	1.42	1.52	1.59	1.69	1.76	1.93	2.10	2.39	2.69	2.99
60	1.07	1.15	1.27	1.44	1.64	1.88	2.03	2.14	2.27	2.39	2.52	2.65	2.90	3.14	3.58	4.03	4.49
100	1.79	1.93	2.10	2.42	2.77	3.11	3.37	3.58	3.79	4.00	4.20	4.41	4.85	5.23	5.98	6.72	7.48
200	3.60	3.90	4.20	4.80	5.50	6.20	6.80	7.20	7.60	8.00	8.40	8.90	9.70	10.50	12.00	13.50	15.00
300	4.90	5.30	5.70	6.60	7.50	8.50	9.20	9.70	10.30	10.80	11.40	12.00	13.10	14.20	16.50	18.90	21.30
400	6.10	6.60	7.10	8.20	9.30	10.50	11.40	12.00	12.70	13.30	14.00	14.70	16.10	17.40	20.10	22.90	25.80
500	7.20	7.80	8.40	9.60	11.00	12.30	13.30	14.10	14.80	15.60	16.40	17.20	18.70	20.20	23.30	26.40	29.60
600	8.20	8.90	9.50	11.00	12.50	14.00	15.10	15.90	16.80	17.70	18.50	19.40	21.10	22.70	26.10	29.50	32.90
700	9.10	9.90	10.60	12.20	13.90	15.60	16.80	17.70	18.60	19.50	20.50	21.40	23.20	25.00	28.60	32.20	35.80
800	10.00	10.80	11.60	13.40	15.10	17.00	18.30	19.30	20.30	21.30	22.20	23.20	25.20	27.00	30.80	34.50	38.20
950	11.30	12.10	13.10	14.90	16.90	19.00	20.40	21.40	22.50	23.60	24.60	25.70	27.70	29.70	33.60	37.40	41.10
1000	11.60	12.60	13.50	15.40	17.50	19.60	21.00	22.10	23.20	24.30	25.40	26.50	28.50	30.50	34.40	38.20	41.90
1200	13.10	14.10	15.10	17.30	19.50	21.80	23.40	24.50	25.70	26.80	28.00	29.10	31.20	33.20	37.10	40.70	44.10
1450	14.60	15.70	16.90	19.20	21.70	24.20	25.90	27.10	28.30	29.40	30.60	31.70	33.80	35.70	39.20	42.30	44.80
1600	15.40	16.60	17.80	20.30	22.80	25.50	27.10	28.30	29.50	30.70	31.80	32.90	34.90	36.60	39.80	42.30	44.10
1800	16.40	17.70	18.90	21.50	24.10	26.80	28.50	29.70	30.90	32.00	33.00	34.00	35.80	37.30	39.80	41.30	43.00
2000	17.30	18.60	19.80	22.50	25.20	28.00	29.70	30.80	31.90	32.90	33.80	34.70	36.20	37.40	38.90		
2200	18.60	19.30	20.60	23.30	26.10	28.90	30.50	31.50	32.50	33.40	34.20	35.00	36.10	36.70			
2400	20.10	20.70	21.30	24.00	26.70	29.50	31.10	32.00	32.80	33.50	34.20	34.70	35.30	35.40			
2600	21.50	22.10	22.70	24.40	27.20	29.90	31.40	32.10	32.70	33.20	33.70	33.90	34.00				
2850	23.10	23.80	24.40	25.60	27.40	30.00	31.30	31.80	32.10	32.30	32.40	32.30	31.70				
3000	24.10	24.70	25.30	26.50	27.50	30.10	31.00	31.60	31.50	31.50	31.40	31.60					
3500			28.00	29.10	30.00	30.70	31.20	31.50	31.70								
4000				30.80	31.40												

Power ratings for other belt widths can be calculated by multiplying by the width correction factors.

Width correction factor

Section and construction 14M

Standard belt width [mm]	40	55	85	115	170
Factor	1.00	1.50	2.50	3.47	5.28

Dimensions and Tolerances

Timing Belt with **optibelt OMEGA** Sections



Timing belts with Optibelt OMEGA sections are produced in a wide range of lengths and widths. Many special lengths, widths and constructions are available. Please consult with our Applications Engineering Department.

Timing belts with Optibelt OMEGA sections are produced to ground category G2 with a thickness tolerance of ± 0.25 mm as standard. If required, the belts can be ground to category G1 with a thickness tolerance of ± 0.13 mm.

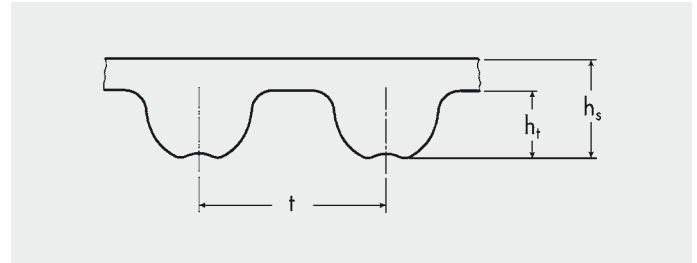

Table 8

Nominal dimensions and weights

Section	2M	3M	5M	8M	14M
Tooth height h_t [mm]	0.70	1.10	1.90	3.20	5.60
Total belt thickness h_s [mm]	1.30	2.30	3.40	5.40	9.50
Tooth pitch t [mm]	2.00	3.00	5.00	8.00	14.00
Weight [kg/m] for 10 mm belt width	0.013	0.024	0.035	0.058	0.100

Length tolerances

Pitch length [mm]	≤ 250	> 250 ≤ 500	> 500 ≤ 750	> 750 ≤ 1000	> 1000 ≤ 1250	> 1250 ≤ 1500	> 1500 ≤ 1750	> 1750 ≤ 2000	> 2000 ≤ 2250	> 2250 ≤ 2500	> 2500 ≤ 2750	> 2750 ≤ 3000	> 3000
Length tolerances given as centre distance deviation	± 0.20	± 0.23	± 0.27	± 0.30	± 0.33	± 0.36	± 0.39	± 0.42	± 0.46	± 0.49	± 0.52	± 0.55	± 0.55 $\pm 0.03^*$

Width tolerance

Standard belt width	Permissible tolerance [mm] of the timing belt			
	Nominal width [mm]	Pitch length up to 838.2 mm	Pitch length 838.3 up to 1676.4 mm	Pitch length over 1676.4 mm
3.0 to 11.0		+ 0.4 - 0.8	+ 0.4 - 0.8	—
11.1 to 38.1		+ 0.8 - 0.8	+ 0.8 - 0.8	+ 0.8 - 1.2
38.2 to 50.8		+ 0.8 - 1.2	+ 1.2 - 1.2	+ 1.2 - 1.6
50.9 to 63.5		+ 1.2 - 1.2	+ 1.2 - 1.6	+ 1.6 - 1.6
63.6 to 76.2		+ 1.2 - 1.6	+ 1.6 - 1.6	+ 1.6 - 2.0
76.3 to 101.6		+ 1.6 - 1.6	+ 1.6 - 2.0	+ 2.0 - 2.0
101.7 to 177.8		+ 2.4 - 2.4	+ 1.6 - 2.0	+ 2.0 - 2.0
177.9 to max.		—	—	+ 4.8 - 6.4

* For longer lengths an additional 0.03 mm should be added in length steps of 250 mm.

Timing Belt Pulleys

for Timing Belts with **optibelt OMEGA** Sections

Section 3M



Power Transmission

Number of teeth	Pitch diameter [mm]	Outside diameter [mm]	Number of teeth	Pitch diameter [mm]	Outside diameter [mm]	Number of teeth	Pitch diameter [mm]	Outside diameter [mm]	Number of teeth	Pitch diameter [mm]	Outside diameter [mm]
10	9.55	8.79	50	47.75	46.99	90	85.94	85.18	130	124.14	123.38
11	10.50	9.74	51	48.70	47.94	91	86.90	86.14	131	125.10	124.33
12	11.46	10.70	52	49.66	48.90	92	87.85	87.09	132	126.05	125.29
13	12.41	11.65	53	50.61	49.85	93	88.81	88.05	133	127.01	126.24
14	13.37	12.61	54	51.57	50.81	94	89.76	89.00	134	127.96	127.20
15	14.32	13.56	55	52.52	51.76	95	90.72	89.96	135	128.92	128.15
16	15.28	14.52	56	53.48	52.72	96	91.67	90.91	136	129.87	129.11
17	16.23	15.47	57	54.43	53.67	97	92.63	91.87	137	130.83	130.06
18	17.19	16.43	58	55.39	54.63	98	93.58	92.82	138	131.78	131.02
19	18.14	17.38	59	56.34	55.58	99	94.54	93.78	139	132.74	131.97
20	19.10	18.34	60	57.30	56.54	100	95.49	94.73	140	133.69	132.93
21	20.05	19.29	61	58.25	57.49	101	96.45	95.69	141	134.65	133.88
22	21.01	20.25	62	59.21	58.45	102	97.40	96.64	142	135.60	134.84
23	21.96	21.20	63	60.16	59.40	103	98.36	97.60	143	136.55	135.79
24	22.92	22.16	64	61.12	60.36	104	99.31	98.55	144	137.51	136.75
25	23.87	23.11	65	62.07	61.31	105	100.27	99.51	145	138.46	137.70
26	24.83	24.07	66	63.03	62.27	106	101.22	100.46	146	139.42	138.66
27	25.78	25.02	67	63.98	63.22	107	102.18	101.42	147	140.37	139.61
28	26.74	25.98	68	64.94	64.18	108	103.13	102.37	148	141.33	140.57
29	27.69	26.93	69	65.89	65.13	109	104.09	103.33	149	142.28	141.52
30	28.65	27.89	70	66.85	66.09	110	105.04	104.28	150	143.24	142.48
31	29.60	28.84	71	67.80	67.04	111	106.00	105.24			
32	30.56	29.80	72	68.75	67.99	112	106.95	106.19			
33	31.51	30.75	73	69.71	68.95	113	107.91	107.15			
34	32.47	31.71	74	70.66	69.90	114	108.86	108.10			
35	33.42	32.66	75	71.62	70.86	115	109.82	109.06			
36	34.38	33.62	76	72.57	71.81	116	110.77	110.01			
37	35.33	34.57	77	73.53	72.77	117	111.73	110.97			
38	36.29	35.53	78	74.48	73.72	118	112.68	111.92			
39	37.24	36.48	79	75.44	74.68	119	113.64	112.88			
40	38.20	37.44	80	76.39	75.63	120	114.59	113.83			
41	39.15	38.39	81	77.35	76.59	121	115.55	114.79			
42	40.11	39.35	82	78.30	77.54	122	116.50	115.74			
43	41.06	40.30	83	79.26	78.50	123	117.46	116.70			
44	42.02	41.26	84	80.21	79.45	124	118.41	117.65			
45	42.97	42.21	85	81.17	80.41	125	119.37	118.61			
46	43.93	43.17	86	82.12	81.36	126	120.32	119.56			
47	44.88	44.12	87	83.08	82.32	127	121.28	120.52			
48	45.84	45.08	88	84.03	83.27	128	122.23	121.47			
49	46.79	46.03	89	84.99	84.23	129	123.19	122.43			

Timing Belt Pulleys

for Timing Belts with **optibelt OMEGA** Sections

Section 5M



Number of teeth	Pitch diameter [mm]	Outside diameter [mm]	Number of teeth	Pitch diameter [mm]	Outside diameter [mm]	Number of teeth	Pitch diameter [mm]	Outside diameter [mm]	Number of teeth	Pitch diameter [mm]	Outside diameter [mm]
12	19.10	17.96	52	82.76	81.62	92	146.42	145.28	132	210.08	208.94
13	20.69	19.55	53	84.35	83.21	93	148.01	146.87	133	211.68	210.54
14	22.28	21.14	54	85.94	84.80	94	149.61	148.47	134	213.27	212.13
15	23.87	22.73	55	87.54	86.40	95	151.20	150.06	135	214.86	213.72
16	25.46	24.32	56	89.13	87.98	96	152.79	151.65	136	216.45	215.31
17	27.06	25.92	57	90.72	89.58	97	154.38	153.24	137	218.04	216.90
18	28.65	27.51	58	92.31	91.17	98	155.97	154.83	138	219.63	218.49
19	30.24	29.10	59	93.90	92.76	99	157.56	156.42	139	221.23	220.09
20	31.83	30.69	60	95.49	94.35	100	159.15	158.01	140	222.82	221.68
21	33.42	32.28	61	97.08	95.94	101	160.75	159.61	141	224.41	223.27
22	35.01	33.87	62	98.68	97.54	102	162.34	161.20	142	226.00	224.86
23	36.61	35.47	63	100.27	99.13	103	163.93	162.79	143	227.59	226.45
24	38.20	37.05	64	101.86	100.72	104	165.52	164.38	144	229.18	228.04
25	39.79	38.65	65	103.45	102.31	105	167.11	165.97	145	230.77	229.63
26	41.38	40.24	66	105.04	103.90	106	168.70	167.56	146	232.37	231.23
27	42.97	41.83	67	106.63	105.49	107	170.30	169.16	147	233.96	232.82
28	44.56	43.42	68	108.23	107.09	108	171.89	170.75	148	235.55	234.41
29	46.15	45.01	69	109.82	108.68	109	173.48	172.34	149	237.14	236.00
30	47.75	46.60	70	111.41	110.27	110	175.07	173.93	150	238.73	237.59
31	49.34	48.20	71	113.00	111.86	111	176.66	175.52			
32	50.93	49.79	72	114.59	113.45	112	178.25	177.11			
33	52.52	51.38	73	116.18	115.04	113	179.85	178.71			
34	54.11	52.97	74	117.77	116.63	114	181.44	180.30			
35	55.70	54.56	75	119.37	118.23	115	183.03	181.89			
36	57.30	56.16	76	120.96	119.82	116	184.62	183.48			
37	58.89	57.75	77	122.55	121.41	117	186.21	185.07			
38	60.48	59.34	78	124.14	123.00	118	187.80	186.66			
39	62.07	60.93	79	125.73	124.59	119	189.39	188.25			
40	63.66	62.52	80	127.32	126.18	120	190.99	189.85			
41	65.25	64.11	81	128.92	127.78	121	192.58	191.44			
42	66.85	65.71	82	130.51	129.37	122	194.17	193.03			
43	68.44	67.30	83	132.10	130.96	123	195.76	194.62			
44	70.03	68.89	84	133.69	132.55	124	197.35	196.21			
45	71.62	70.48	85	135.28	134.14	125	198.94	197.80			
46	73.21	72.07	86	136.87	135.73	126	200.54	199.40			
47	74.80	73.66	87	138.46	137.32	127	202.13	200.99			
48	76.39	75.25	88	140.06	138.92	128	203.72	202.58			
49	77.99	76.85	89	141.65	140.51	129	205.31	204.17			
50	79.58	78.43	90	143.24	142.10	130	206.90	205.76			
51	81.17	80.03	91	144.83	143.69	131	208.49	207.35			

Timing Belt Pulleys

for Timing Belts with **optibelt OMEGA** Sections

Section 8M



Power Transmission

Number of teeth	Pitch diameter [mm]	Outside diameter [mm]	Number of teeth	Pitch diameter [mm]	Outside diameter [mm]	Number of teeth	Pitch diameter [mm]	Outside diameter [mm]	Number of teeth	Pitch diameter [mm]	Outside diameter [mm]
22	56.02	54.65	67	170.61	169.24	112	285.21	283.83	157	399.80	398.43
23	58.57	57.20	68	173.16	171.79	113	287.75	286.38	158	402.34	400.97
24	61.12	59.75	69	175.71	174.34	114	290.30	288.93	159	404.89	403.52
25	63.66	62.29	70	178.25	176.88	115	292.85	291.47	160	407.44	406.07
26	66.21	64.84	71	180.80	179.43	116	295.39	294.02	161	409.98	408.61
27	68.75	67.38	72	183.35	181.97	117	297.94	296.57	162	412.53	411.16
28	71.30	69.93	73	185.89	184.52	118	300.48	299.11	163	415.08	413.70
29	73.85	72.48	74	188.44	187.07	119	303.03	301.66	164	417.62	416.25
30	76.39	75.13	75	190.99	189.61	120	305.58	304.21	165	420.17	418.80
31	78.94	77.65	76	193.53	192.16	121	308.12	306.75	166	422.72	421.34
32	81.49	80.16	77	196.08	194.71	122	310.67	309.30	167	425.26	423.89
33	84.03	82.68	78	198.62	197.25	123	313.22	311.85	168	427.81	426.44
34	86.58	85.22	79	201.17	199.81	124	315.76	314.39	169	430.35	428.98
35	89.13	87.76	80	203.72	202.35	125	318.31	316.94	170	432.90	431.53
36	91.67	90.30	81	206.26	204.89	126	320.86	319.48	171	435.45	434.08
37	94.22	92.85	82	208.81	207.44	127	323.41	322.03	172	437.99	436.62
38	96.77	95.39	83	211.36	209.99	128	325.95	324.58	173	440.54	439.17
39	99.31	97.94	84	213.90	212.53	129	328.50	327.12	174	443.09	441.72
40	101.86	100.49	85	216.45	215.08	130	331.04	329.67	175	445.63	444.26
41	104.41	103.03	86	219.00	217.63	131	333.59	332.22	176	448.18	446.81
42	106.95	105.58	87	221.54	220.17	132	336.14	334.76	177	450.73	449.36
43	109.50	108.13	88	224.09	222.72	133	338.68	337.31	178	453.27	451.90
44	112.05	110.67	89	226.54	225.27	134	341.23	339.86	179	455.82	454.45
45	114.59	113.22	90	229.18	227.81	135	343.77	342.40	180	458.37	456.99
46	117.14	115.77	91	231.73	230.36	136	346.32	344.95	181	460.91	459.54
47	119.68	118.31	92	234.28	232.90	137	348.87	347.50	182	463.46	462.09
48	122.23	120.86	93	236.82	235.45	138	351.41	350.04	183	466.01	464.63
49	124.78	123.41	94	239.37	238.00	139	353.96	352.59	184	468.55	467.18
50	127.32	125.95	95	241.92	240.54	140	356.51	355.14	185	471.10	469.73
51	129.87	128.50	96	244.46	243.09	141	359.05	357.68	186	473.65	472.27
52	132.42	131.05	97	247.01	245.64	142	361.60	360.23	187	476.19	474.82
53	134.96	133.59	98	249.55	248.18	143	364.15	362.77	188	478.74	477.37
54	137.51	136.14	99	252.10	250.73	144	366.69	365.32	189	481.28	479.91
55	140.06	138.68	100	254.65	253.28	145	369.24	367.87	190	483.83	482.46
56	142.60	141.23	101	257.19	255.82	146	371.79	370.41	191	486.38	485.01
57	145.15	143.78	102	259.74	258.37	147	374.33	372.96	192	488.92	487.55
58	147.70	146.32	103	262.29	260.92	148	376.88	375.51			
59	150.24	148.87	104	264.83	263.46	149	379.43	378.05			
60	152.79	151.42	105	267.38	266.01	150	381.97	380.60			
61	155.34	153.96	106	269.93	268.56	151	384.52	383.15			
62	157.88	156.51	107	272.47	271.10	152	387.06	385.70			
63	160.43	159.06	108	275.02	273.65	153	389.61	388.24			
64	162.97	161.60	109	277.57	276.19	154	392.16	390.79			
65	165.52	164.15	110	280.11	278.74	155	394.70	393.33			
66	168.07	166.70	111	282.66	281.29	156	397.25	395.88			

Timing Belt Pulleys

for Timing Belts with **optibelt OMEGA** Sections

Section 14M



Power Transmission

Number of teeth	Pitch diameter [mm]	Outside diameter [mm]	Number of teeth	Pitch diameter [mm]	Outside diameter [mm]	Number of teeth	Pitch diameter [mm]	Outside diameter [mm]	Number of teeth	Pitch diameter [mm]	Outside diameter [mm]
28	124.78	122.12	73	325.31	322.52	118	525.85	523.05	163	726.38	723.59
29	129.23	126.57	74	329.77	326.97	119	530.30	527.51	164	730.84	728.05
30	133.69	130.99	75	334.22	331.43	120	534.76	531.97	165	735.30	732.50
31	138.15	135.46	76	338.68	335.89	121	539.22	536.42	166	739.75	736.96
32	142.60	139.88	77	343.14	340.34	122	543.67	540.88	167	744.21	741.41
33	147.06	144.35	78	347.59	344.80	123	548.13	545.34	168	748.66	745.87
34	151.51	148.79	79	352.05	349.26	124	552.59	549.79	169	753.12	750.33
35	155.97	153.24	80	356.51	353.71	125	557.04	554.25	170	757.58	754.78
36	160.43	157.68	81	360.96	358.17	126	561.50	558.70	171	762.03	759.24
37	164.88	162.13	82	365.42	362.63	127	565.95	563.16	172	766.49	763.70
38	169.34	166.60	83	369.88	367.08	128	570.41	567.62	173	770.95	768.15
39	173.80	171.02	84	374.33	371.54	129	574.87	572.07	174	775.40	772.61
40	178.25	175.49	85	378.79	375.99	130	579.32	576.53	175	779.86	777.06
41	182.71	179.92	86	383.24	380.45	131	583.78	580.99	176	784.32	781.52
42	187.17	184.37	87	387.70	384.91	132	588.24	585.44	177	788.77	785.98
43	191.62	188.83	88	392.16	389.36	133	592.69	589.90	178	793.23	790.43
44	196.08	193.28	89	396.61	393.82	134	597.15	594.35	179	797.68	794.89
45	200.53	197.74	90	401.07	398.28	135	601.61	598.81	180	802.14	799.35
46	204.99	202.30	91	405.53	402.73	136	606.06	603.27	181	806.60	803.80
47	209.45	206.65	92	409.98	407.19	137	610.52	607.72	182	811.05	808.26
48	213.90	211.11	93	414.44	411.64	138	614.97	612.18	183	815.51	812.72
49	218.36	215.57	94	418.90	416.10	139	619.43	616.64	184	819.97	817.17
50	222.82	220.02	95	423.35	420.56	140	623.89	621.09	185	824.42	821.63
51	227.27	224.48	96	427.81	425.01	141	628.34	625.55	186	828.88	826.08
52	231.73	228.94	97	432.26	429.47	142	632.80	630.01	187	833.33	830.54
53	236.19	233.39	98	436.72	433.93	143	637.26	634.46	188	837.79	835.00
54	240.64	237.85	99	441.18	438.38	144	641.71	638.92	189	842.25	839.45
55	245.10	242.30	100	445.63	442.84	145	646.17	643.37	190	846.70	843.91
56	249.55	246.76	101	450.09	447.30	146	650.63	647.83	191	851.16	848.37
57	254.01	251.22	102	454.55	451.75	147	655.08	652.29	192	855.62	852.82
58	258.47	255.67	103	459.00	456.21	148	659.54	656.74	216	962.57	959.77
59	262.92	260.13	104	463.46	460.66	149	663.99	661.20			
60	267.38	264.59	105	467.92	465.12	150	668.45	665.66			
61	271.84	269.04	106	472.37	469.58	151	672.91	670.11			
62	276.29	273.50	107	476.83	474.03	152	677.36	674.57			
63	280.75	277.95	108	481.28	478.49	153	681.82	679.03			
64	285.21	282.41	109	485.74	482.95	154	686.28	683.48			
65	289.66	286.87	110	490.20	487.40	155	690.73	687.94			
66	294.12	291.32	111	494.65	491.86	156	695.19	692.39			
67	298.57	295.78	112	499.11	496.32	157	699.64	696.85			
68	303.03	300.24	113	503.57	500.77	158	704.10	701.31			
69	307.49	304.69	114	508.02	505.23	159	708.56	705.76			
70	311.94	309.15	115	512.48	509.68	160	713.01	710.22			
71	316.40	313.61	116	516.93	514.14	161	717.47	714.68			
72	320.86	318.06	117	521.39	518.60	162	721.93	719.13			

Timing Belt Pulleys

optibelt *ZRS HTD*[®] Timing Belt Pulleys for Cylindrical Bore

Section 3M



Power Transmission

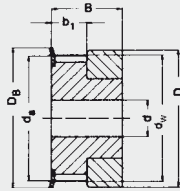

Type 1F

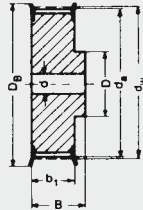

Type 6F

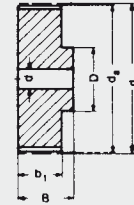

Type 6

Section 3M – pitch 3 mm for belt width of 6 mm

(Non stock items)

Designation	Number of teeth	Type	Material	d_w [mm]	d_a [mm]	D_B [mm]	b_1 [mm]	B [mm]	D [mm]	Pilot bore d [mm]	Finish bore d_{max} [mm]	Weight \approx [kg]
10-3M-6	10	1F	Al	9.55	8.79	13.0	7.2	14.5	13.0	—	3	
12-3M-6	12	1F	Al	11.46	10.70	15.0	7.2	14.5	15.0	—	5	
14-3M-6	14	1F	Al	13.37	12.61	16.0	7.2	14.5	16.0	—	6	
15-3M-6	15	1F	Al	14.32	13.56	17.5	7.2	14.5	17.5	—	6	
16-3M-6	16	6F	Al	15.28	14.52	18.0	9.8	17.5	10.0	4	7	
18-3M-6	18	6F	Al	17.19	16.43	19.5	9.8	17.5	11.0	6	8	
20-3M-6	20	6F	Al	19.10	18.34	23.0	9.8	17.5	13.0	6	9	
21-3M-6	21	6F	Al	20.05	19.29	25.0	9.8	17.5	14.0	6	9	
22-3M-6	22	6F	Al	21.01	20.25	25.0	9.8	17.5	14.0	6	9	
24-3M-6	24	6F	Al	22.92	22.16	25.0	9.8	17.5	14.0	6	9	
26-3M-6	26	6F	Al	24.83	24.07	28.0	9.8	17.5	16.0	6	11	
28-3M-6	28	6F	Al	26.74	25.98	32.0	9.8	17.5	18.0	6	12	
30-3M-6	30	6F	Al	28.65	27.89	32.0	9.8	17.5	20.0	6	14	
32-3M-6	32	6F	Al	30.56	29.80	36.0	9.8	17.5	22.0	6	15	
36-3M-6	36	6F	Al	34.38	33.62	38.0	10.3	18.0	26.0	6	16	
40-3M-6	40	6F	Al	38.20	37.44	42.0	10.3	18.0	28.0	6	18	
44-3M-6	44	6F	Al	42.02	41.26	48.0	10.3	18.0	33.0	6	20	
48-3M-6	48	6	Al	45.84	45.08	—	10.3	18.6	33.0	8	20	
60-3M-6	60	6	Al	57.30	56.54	—	10.3	18.6	33.0	8	20	
72-3M-6	72	6	Al	68.75	67.99	—	10.3	18.6	33.0	8	20	

Section 3M – pitch 3 mm for belt width of 9 mm

10-3M-9	10	1F	Al	9.55	8.79	13.0	10.2	17.5	13.0	—	3	0.004
12-3M-9	12	1F	Al	11.46	10.70	15.0	10.2	17.5	15.0	—	5	0.006
14-3M-9	14	1F	Al	13.37	12.61	16.0	10.2	17.5	16.0	—	6	0.007
15-3M-9	15	1F	Al	14.32	13.56	17.5	10.2	17.5	17.5	—	6	0.008
16-3M-9	16	6F	Al	15.28	14.52	18.0	12.8	20.6	10.0	4	7	0.007
18-3M-9	18	6F	Al	17.19	16.43	19.5	12.8	20.6	11.0	6	8	0.008
20-3M-9	20	6F	Al	19.10	18.34	23.0	12.8	20.6	13.0	6	9	0.010
21-3M-9	21	6F	Al	20.05	19.29	25.0	12.8	20.6	14.0	6	9	0.013
22-3M-9	22	6F	Al	21.01	20.25	25.0	12.8	20.6	14.0	6	9	0.014
24-3M-9	24	6F	Al	22.92	22.16	25.0	12.8	20.6	14.0	6	9	0.016
26-3M-9	26	6F	Al	24.83	24.07	28.0	12.8	20.6	16.0	6	11	0.018
28-3M-9	28	6F	Al	26.74	25.98	32.0	12.8	20.6	18.0	6	12	0.024
30-3M-9	30	6F	Al	28.65	27.89	32.0	12.8	20.6	20.0	6	14	0.028
32-3M-9	32	6F	Al	30.56	29.80	36.0	12.8	20.6	22.0	6	15	0.032
36-3M-9	36	6F	Al	34.38	33.62	38.0	13.4	22.2	26.0	6	16	0.045
40-3M-9	40	6F	Al	38.20	37.44	42.0	13.4	22.2	28.0	6	18	0.055
44-3M-9	44	6F	Al	42.02	41.26	48.0	13.4	22.2	33.0	6	20	0.074
48-3M-9	48	6	Al	45.84	45.08	—	13.4	22.2	33.0	8	20	0.074
60-3M-9	60	6	Al	57.30	56.54	—	13.4	22.2	33.0	8	20	0.106
72-3M-9	72	6	Al	68.75	67.99	—	13.4	22.2	33.0	8	20	0.145

Timing Belt Pulleys

optibelt ZRS HTD® Timing Belt Pulleys for Cylindrical Bore

Section 3M and 5M



Power Transmission

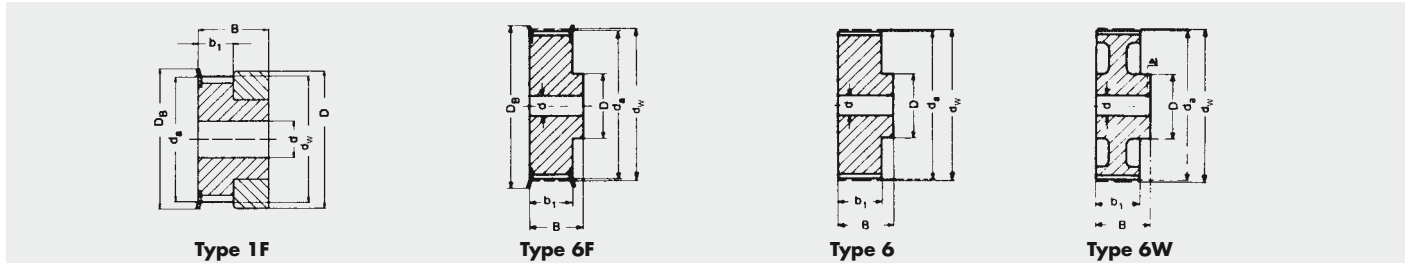

Section 3M – pitch 3 mm for belt width of 15 mm

Designation	Number of teeth	Type	Material	d _w [mm]	d _a [mm]	D _B [mm]	b ₁ [mm]	B [mm]	D [mm]	Pilot bore d [mm]	Finish bore d _{max} [mm]	Weight ≈ [kg]
10-3M-15	10	1F	Al	9.55	8.79	13.0	17.0	26	13.0	—	3	0.006
12-3M-15	12	1F	Al	11.46	10.70	15.0	17.0	26	15.0	—	5	0.008
14-3M-15	14	1F	Al	13.37	12.61	16.0	17.0	26	16.0	—	6	0.010
15-3M-15	15	1F	Al	14.32	13.56	17.5	17.0	26	17.5	—	6	0.012
16-3M-15	16	6F	Al	15.28	14.52	18.0	19.5	26	10.0	4	7	0.010
18-3M-15	18	6F	Al	17.19	16.43	19.5	19.5	26	11.0	6	8	0.012
20-3M-15	20	6F	Al	19.10	18.34	23.0	19.5	26	13.0	6	9	0.014
21-3M-15	21	6F	Al	20.05	19.29	25.0	19.5	26	14.0	6	9	0.016
22-3M-15	22	6F	Al	21.01	20.25	25.0	19.5	26	14.0	6	9	0.018
24-3M-15	24	6F	Al	22.92	22.16	25.0	19.5	26	14.0	6	9	0.020
26-3M-15	26	6F	Al	24.83	24.07	28.0	19.5	26	16.0	6	11	0.027
28-3M-15	28	6F	Al	26.74	25.98	32.0	19.5	26	18.0	6	12	0.030
30-3M-15	30	6F	Al	28.65	27.89	32.0	19.5	26	20.0	6	14	0.035
32-3M-15	32	6F	Al	30.56	29.80	36.0	19.5	26	22.0	6	15	0.042
36-3M-15	36	6F	Al	34.38	33.62	38.0	20.0	30	26.0	6	16	0.060
40-3M-15	40	6F	Al	38.20	37.44	42.0	20.0	30	28.0	6	18	0.075
44-3M-15	44	6F	Al	42.02	41.26	48.0	20.0	30	33.0	6	20	0.100
48-3M-15	48	6	Al	45.84	45.08	—	20.0	30	33.0	8	20	0.103
60-3M-15	60	6	Al	57.30	56.54	—	20.0	30	33.0	8	20	0.150
72-3M-15	72	6	Al	68.75	67.99	—	20.0	30	33.0	8	20	0.212

Section 5M – pitch 5 mm for belt width of 9 mm

12-5M-9	12	6F	St	19.10	17.96	23	14.5	20.0	13.0	4	7	0.028
14-5M-9	14	6F	St	22.28	21.14	25	14.5	20.0	14.0	6	8	0.034
15-5M-9	15	6F	St	23.87	22.73	28	14.5	20.0	16.0	6	10	0.042
16-5M-9	16	6F	St	25.46	24.32	28	14.5	20.0	16.5	6	10	0.050
18-5M-9	18	6F	St	28.65	27.51	32	14.5	20.0	20.0	6	12	0.070
20-5M-9	20	6F	St	31.83	30.69	36	14.5	22.5	23.0	6	14	0.094
21-5M-9	21	6F	St	33.42	32.28	38	14.5	22.5	24.0	6	14	0.110
22-5M-9	22	6F	St	35.01	33.87	38	14.5	22.5	25.5	6	14	0.118
24-5M-9	24	6F	St	38.20	37.06	42	14.5	22.5	27.0	6	16	0.145
26-5M-9	26	6F	St	41.38	40.24	44	14.5	22.5	30.0	6	18	0.170
28-5M-9	28	6F	St	44.56	43.42	48	14.5	22.5	30.5	6	18	0.200
30-5M-9	30	6F	St	47.75	46.61	51	14.5	22.5	35.0	6	20	0.236
32-5M-9	32	6F	St	50.93	49.79	54	14.5	22.5	38.0	8	22	0.270
36-5M-9	36	6F	St	57.30	56.16	60	14.5	22.5	38.0	8	22	0.324
40-5M-9	40	6F	St	63.66	62.52	71	14.5	22.5	38.0	8	22	0.400
44-5M-9	44	6W	Al	70.03	68.89	—	14.5	25.5	38.0	8	22	0.170
48-5M-9	48	6W	Al	76.39	75.25	—	14.5	25.5	45.0	8	25	0.182
60-5M-9	60	6W	Al	95.49	94.35	—	14.5	25.5	45.0	8	25	0.230
72-5M-9	72	6W	Al	114.59	113.45	—	14.5	25.5	45.0	8	25	0.270

Timing Belt Pulleys

optibelt *ZRS HTD*[®] Timing Belt Pulleys for Cylindrical Bore

Section 5M



Power Transmission

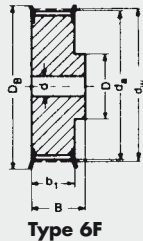

Type 6F

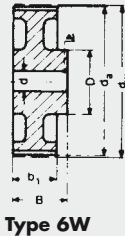

Type 6W

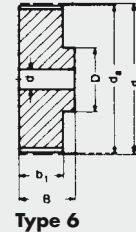

Type 6

Section 5M – pitch 5 mm for belt width of 15 mm

Designation	Number of teeth	Type	Material	d_w [mm]	d_o [mm]	D_B [mm]	b_1 [mm]	B [mm]	D [mm]	Pilot bore d [mm]	Finish bore d_{max} [mm]	Weight \approx [kg]
12-5M-15	12	6F	St	19.10	17.96	25	20.5	26	13.0	4	7	0.034
14-5M-15	14	6F	St	22.28	21.14	25	20.5	26	14.0	6	8	0.046
15-5M-15	15	6F	St	23.87	22.73	28	20.5	26	16.0	6	10	0.056
16-5M-15	16	6F	St	25.46	24.32	28	20.5	26	16.5	6	10	0.064
18-5M-15	18	6F	St	28.65	27.51	32	20.5	26	20.0	6	12	0.086
20-5M-15	20	6F	St	31.83	30.69	36	20.5	26	23.0	6	14	0.112
21-5M-15	21	6F	St	33.42	32.28	38	20.5	26	24.0	6	14	0.130
22-5M-15	22	6F	St	35.01	33.87	38	20.5	26	25.5	6	14	0.140
24-5M-15	24	6F	St	38.20	37.06	42	20.5	28	27.0	6	16	0.180
26-5M-15	26	6F	St	41.38	40.24	44	20.5	28	30.0	6	18	0.220
28-5M-15	28	6F	St	44.56	43.42	48	20.5	28	30.5	6	18	0.250
30-5M-15	30	6F	St	47.75	46.61	51	20.5	28	35.0	6	20	0.300
32-5M-15	32	6F	St	50.93	49.79	54	20.5	28	38.0	8	22	0.350
36-5M-15	36	6F	St	57.30	56.16	60	20.5	28	38.0	8	22	0.426
40-5M-15	40	6F	St	63.66	62.52	71	20.5	28	38.0	8	22	0.520
44-5M-15	44	6W	Al	70.03	68.89	—	20.5	30	38.0	8	22	0.225
48-5M-15	48	6W	Al	76.39	75.25	—	20.5	30	38.0	8	25	0.187
60-5M-15	60	6W	Al	95.49	94.35	—	20.5	30	50.0	8	25	0.305
72-5M-15	72	6W	Al	114.59	113.45	—	20.5	30	50.0	8	25	0.375

Section 5M – pitch 5 mm for belt width of 25 mm

12-5M-25	12	6F	St	19.10	17.96	25	30	36	13.0	4	7	0.050
14-5M-25	14	6F	St	22.28	21.14	25	30	36	14.0	6	8	0.070
15-5M-25	15	6F	St	23.87	22.73	28	30	36	16.0	6	10	0.080
16-5M-25	16	6F	St	25.46	24.32	28	30	36	16.5	6	10	0.100
18-5M-25	18	6F	St	28.65	27.51	32	30	36	20.0	6	12	0.120
20-5M-25	20	6F	St	31.83	30.69	36	30	36	23.0	6	14	0.160
21-5M-25	21	6F	St	33.42	32.28	38	30	38	24.0	6	14	0.190
22-5M-25	22	6F	St	35.01	33.87	38	30	38	25.5	6	14	0.210
24-5M-25	24	6F	St	38.20	37.06	42	30	38	27.0	6	16	0.250
26-5M-25	26	6F	St	41.38	40.24	44	30	38	30.0	6	18	0.300
28-5M-25	28	6F	St	44.56	43.42	48	30	38	30.5	6	18	0.350
30-5M-25	30	6F	St	47.75	46.61	51	30	38	35.0	6	20	0.420
32-5M-25	32	6F	St	50.93	49.79	54	30	38	38.0	8	22	0.480
36-5M-25	36	6F	St	57.30	56.16	60	30	38	38.0	8	22	0.590
40-5M-25	40	6F	St	63.66	62.52	71	30	38	38.0	8	22	0.740
44-5M-25	44	6W	Al	70.03	68.89	—	30	40	38.0	8	22	0.320
48-5M-25	48	6W	Al	76.39	75.25	—	30	40	38.0	8	25	0.275
60-5M-25	60	6W	Al	95.49	94.35	—	30	40	50.0	8	25	0.435
72-5M-25	72	6W	Al	114.59	113.45	—	30	40	50.0	8	25	0.525

Timing Belt Pulleys

optibelt ZRS HTD® Timing Belt Pulleys for Cylindrical Bore

Section 8M



Power Transmission

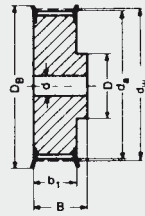

Type 6F

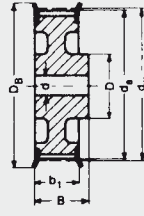

Type 6WF

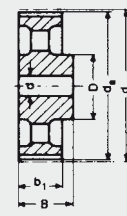

Type 6A

Section 8M – pitch 8 mm for belt width of 20 mm

Designation	Number of teeth	Type	Material	d _w [mm]	d _s [mm]	D _B [mm]	b ₁ [mm]	B [mm]	D [mm]	D ₁ [mm]	Pilot bore d [mm]	Finish bore d _{max} [mm]	Weight ≈ [kg]
22-8M-20	22	6F	St	56.02	54.65	60.0	28	38	43	—	12	30	0.54
24-8M-20	24	6F	St	61.12	59.75	66.0	28	38	45	—	12	30	0.65
26-8M-20	26	6F	St	66.21	64.84	71.0	28	38	50	—	12	35	0.80
28-8M-20	28	6F	St	71.30	69.93	75.0	28	38	50	—	15	35	0.87
30-8M-20	30	6F	St	76.39	75.02	83.0	28	38	55	—	15	35	1.02
32-8M-20	32	6F	St	81.49	80.12	87.0	28	38	60	—	15	40	1.20
34-8M-20	34	6F	St	86.58	85.22	91.0	28	38	70	—	15	45	1.40
36-8M-20	36	6F	St	91.67	90.30	98.5	28	38	70	—	15	45	1.55
38-8M-20	38	6F	St	96.77	95.39	103.0	28	38	75	—	15	45	1.65
40-8M-20	40	6F	GG	101.86	100.49	106.0	28	38	75	—	15	45	1.80
44-8M-20	44	6F	GG	112.05	110.67	119.0	28	38	75	—	15	45	2.10
48-8M-20	48	6F	GG	122.23	120.86	127.0	28	38	75	—	15	45	2.44
56-8M-20	56	6WF	GG	142.60	141.23	148.0	28	38	80	117	15	45	2.60
64-8M-20	64	6WF	GG	162.97	161.60	168.0	28	38	80	137	15	45	2.90
72-8M-20	72	6WF	GG	183.35	181.97	192.0	28	38	80	158	15	45	3.10
80-8M-20	80	6A	GG	203.72	202.35	—	28	38	90	180	15	50	3.80
90-8M-20	90	6A	GG	229.18	227.81	—	28	38	90	204	15	50	4.20
112-8M-20	112	6A	GG	285.21	283.83	—	28	38	90	260	18	50	5.20
144-8M-20	144	6A	GG	366.69	365.32	—	28	38	90	341	20	50	7.50
168-8M-20	168	6A	GG	427.81	426.44	—	28	38	100	402	20	55	10.00
192-8M-20	192	6A	GG	488.92	487.55	—	28	38	100	463	20	55	14.40

Section 8M – pitch 8 mm for belt width of 30 mm

22-8M-30	22	6F	St	56.02	54.65	60.0	38	48	43	—	12	30	0.69
24-8M-30	24	6F	St	61.12	59.75	66.0	38	48	45	—	12	30	0.84
26-8M-30	26	6F	St	66.21	64.84	71.0	38	48	50	—	12	35	1.00
28-8M-30	28	6F	St	71.30	69.93	75.0	38	48	50	—	15	35	1.12
30-8M-30	30	6F	St	76.39	75.02	83.0	38	48	55	—	15	35	1.32
32-8M-30	32	6F	St	81.49	80.12	87.0	38	48	60	—	15	40	1.50
34-8M-30	34	6F	St	86.58	85.22	91.0	38	48	70	—	15	45	1.80
36-8M-30	36	6F	St	91.67	90.30	98.5	38	48	70	—	15	45	1.99
38-8M-30	38	6F	St	96.77	95.39	103.0	38	48	75	—	15	45	2.27
40-8M-30	40	6F	GG	101.86	100.49	106.0	38	48	75	—	15	45	2.40
44-8M-30	44	6F	GG	112.05	110.67	119.0	38	48	75	—	15	45	2.80
48-8M-30	48	6F	GG	122.23	120.86	127.0	38	48	75	—	15	45	3.20
56-8M-30	56	6WF	GG	142.60	141.23	148.0	38	48	90	117	15	50	3.60
64-8M-30	64	6WF	GG	162.97	161.60	168.0	38	48	90	137	15	50	4.30
72-8M-30	72	6WF	GG	183.35	181.97	192.0	38	48	95	158	15	50	4.80
80-8M-30	80	6A	GG	203.72	202.35	—	38	48	100	180	15	55	5.10
90-8M-30	90	6A	GG	229.18	227.81	—	38	48	100	204	15	55	5.70
112-8M-30	112	6A	GG	285.21	283.83	—	38	48	100	260	18	55	6.80
144-8M-30	144	6A	GG	366.69	365.32	—	38	48	100	341	20	55	9.30
168-8M-30	168	6A	GG	427.81	426.44	—	38	48	100	402	20	55	11.40
192-8M-30	192	6A	GG	488.92	487.55	—	38	48	100	463	20	55	16.00

St = Steel GG = Grey cast iron Subject to production changes.

Timing Belt Pulleys

optibelt *ZRS HTD*® Timing Belt Pulleys for Cylindrical Bore

Section 8M



Power Transmission

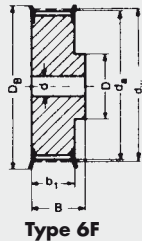

Type 6F

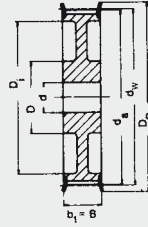

Type 10WF

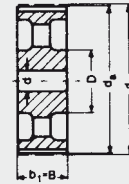

Type 10A

Section 8M – pitch 8 mm for belt width of 50 mm

Designation	Number of teeth	Type	Material	d_w [mm]	d_o [mm]	D_B [mm]	b_1 [mm]	B [mm]	D [mm]	D_i [mm]	Pilot bore d [mm]	Finish bore d_{max} [mm]	Weight ≈ [kg]
22-8M-50	22	6F	St	56.02	54.65	60.0	60	70	43	—	12	30	1.00
24-8M-50	24	6F	St	61.12	59.75	66.0	60	70	45	—	12	30	1.20
26-8M-50	26	6F	St	66.21	64.84	71.0	60	70	50	—	12	35	1.50
28-8M-50	28	6F	St	71.30	70.08	75.0	60	70	50	—	15	35	1.67
30-8M-50	30	6F	St	76.39	75.13	83.0	60	70	55	—	15	35	1.97
32-8M-50	32	6F	St	81.49	80.16	87.0	60	70	60	—	15	40	2.27
34-8M-50	34	6F	St	86.58	85.22	91.0	60	70	70	—	15	45	2.69
36-8M-50	36	6F	St	91.67	90.30	98.5	60	70	70	—	15	45	2.97
38-8M-50	38	6F	St	96.77	95.39	103.0	60	70	75	—	15	45	3.23
40-8M-50	40	6F	GG	101.86	100.49	106.0	60	70	75	—	18	45	3.50
44-8M-50	44	6F	GG	112.05	110.67	119.0	60	70	75	—	18	45	3.90
48-8M-50	48	6F	GG	122.23	120.86	127.0	60	70	80	—	18	45	4.30
56-8M-50	56	10WF	GG	142.60	141.23	148.0	60	60	90	117	18	50	5.00
64-8M-50	64	10WF	GG	162.97	161.60	168.0	60	60	100	137	18	55	5.60
72-8M-50	72	10WF	GG	183.35	181.97	192.0	60	60	100	158	18	55	6.80
80-8M-50	80	10A	GG	203.72	202.35	—	60	60	110	180	18	60	6.90
90-8M-50	90	10A	GG	229.18	227.81	—	60	60	110	204	18	60	8.60
112-8M-50	112	10A	GG	285.21	283.83	—	60	60	110	260	18	60	9.60
144-8M-50	144	10A	GG	366.69	365.32	—	60	60	110	341	20	60	13.80
168-8M-50	168	10A	GG	427.81	426.44	—	60	60	120	402	20	65	16.00
192-8M-50	192	10A	GG	488.92	487.55	—	60	60	130	463	20	70	22.40

Section 8M – pitch 8 mm for belt width of 85 mm

22-8M-85	22	6F	St	56.02	54.65	60.0	95	105	43	—	12	30	1.55
24-8M-85	24	6F	St	61.12	59.75	66.0	95	105	45	—	12	30	1.90
26-8M-85	26	6F	St	66.21	64.84	71.0	95	105	50	—	12	35	2.25
28-8M-85	28	6F	St	71.30	70.08	75.0	95	105	50	—	15	35	2.55
30-8M-85	30	6F	St	76.39	75.13	83.0	95	105	55	—	15	35	3.00
32-8M-85	32	6F	St	81.49	80.16	87.0	95	105	60	—	15	40	3.57
34-8M-85	34	6F	St	86.58	85.22	91.0	95	105	70	—	15	45	4.00
36-8M-85	36	6F	St	91.67	90.30	98.5	95	105	70	—	15	45	4.50
38-8M-85	38	6F	St	96.77	95.39	103.0	95	105	75	—	15	45	4.90
40-8M-85	40	6F	GG	101.86	100.49	106.0	95	105	75	—	18	45	5.20
44-8M-85	44	6F	GG	112.05	110.67	119.0	95	105	75	—	18	45	6.60
48-8M-85	48	6F	GG	122.23	120.86	127.0	95	105	80	—	18	45	7.60
56-8M-85	56	6F	GG	142.60	141.23	148.0	95	105	80	—	20	50	9.80
64-8M-85	64	10WF	GG	162.97	161.60	168.0	95	95	100	137	20	55	10.40
72-8M-85	72	10WF	GG	183.35	181.97	192.0	95	95	110	158	20	60	11.40
80-8M-85	80	10A	GG	203.72	202.35	—	95	95	110	180	20	60	11.10
90-8M-85	90	10A	GG	229.18	227.81	—	95	95	110	204	20	60	13.20
112-8M-85	112	10A	GG	285.21	283.83	—	95	95	110	260	24	60	16.30
144-8M-85*	144	10A	GG	366.69	365.32	—	95	95	120	341	24	65	21.50
168-8M-85*	168	10A	GG	427.81	426.44	—	95	95	120	402	24	65	26.10
192-8M-85*	192	10A	GG	488.92	487.55	—	95	95	130	463	24	70	30.60

Timing Belt Pulleys

optibelt ZRS HTD® Timing Belt Pulleys for Cylindrical Bore

Section 14M



Power Transmission

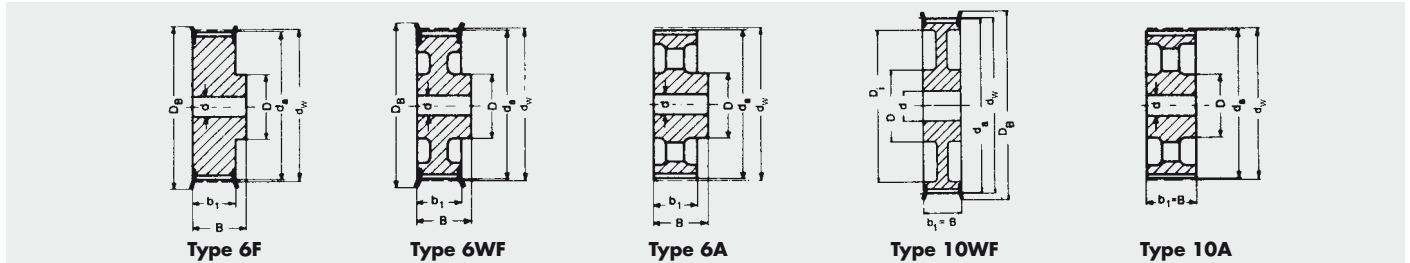

Section 14M – pitch 14 mm for belt width of 40 mm

Designation	Number of teeth	Type	Material	d_w [mm]	d_a [mm]	D_B [mm]	b_1 [mm]	B [mm]	D [mm]	D_i [mm]	Pilot bore d [mm]	Finish bore d_{max} [mm]	Weight \approx [kg]
28-14M-40	28	6F	GG	124.78	122.12	127	54	69	100	—	24	60	4.73
29-14M-40	29	6F	GG	129.23	126.57	138	54	69	100	—	24	60	5.09
30-14M-40	30	6F	GG	133.69	130.99	138	54	69	100	—	24	60	5.45
32-14M-40	32	6F	GG	142.60	139.88	154	54	69	100	—	24	70	6.17
34-14M-40	34	6F	GG	151.52	148.79	160	54	69	100	—	24	70	6.88
36-14M-40	36	6F	GG	160.43	157.68	168	54	69	100	—	24	70	7.60
38-14M-40	38	6F	GG	169.34	166.60	183	54	69	120	—	24	70	8.28
40-14M-40	40	6F	GG	178.25	175.49	188	54	69	120	—	24	70	9.26
44-14M-40	44	6F	GG	196.08	193.28	211	54	69	120	—	24	70	10.32
48-14M-40	48	6WF	GG	213.90	211.11	226	54	69	135	172	24	70	11.50
56-14M-40	56	6WF	GG	249.55	246.76	256	54	69	135	207	28	70	13.05
64-14M-40	64	6WF	GG	285.21	282.41	296	54	69	135	242	28	70	14.40
72-14M-40	72	6A	GG	320.86	318.06	—	54	69	135	278	28	70	16.90
80-14M-40	80	6A	GG	356.51	353.71	—	54	69	135	314	28	70	18.50
90-14M-40	90	6A	GG	401.07	398.28	—	54	69	135	358	28	70	20.00
112-14M-40*	112	6A	GG	499.11	496.32	—	54	69	135	456	28	70	26.70
144-14M-40*	144	6A	GG	641.71	638.92	—	54	69	135	600	28	70	35.00
168-14M-40*	168	6A	GG	748.66	745.87	—	54	69	135	706	28	70	44.20
192-14M-40*	192	6A	GG	855.62	852.82	—	54	69	135	813	28	70	52.20
216-14M-40*	216	6A	GG	962.57	959.77	—	54	69	150	920	28	80	60.00

Section 14M – pitch 14 mm for belt width of 55 mm

28-14M-55	28	6F	GG	124.78	122.12	127	70	85	100	—	24	60	5.60
29-14M-55	29	6F	GG	129.23	126.57	138	70	85	100	—	24	60	6.10
30-14M-55	30	6F	GG	133.69	130.99	138	70	85	100	—	24	60	6.60
32-14M-55	32	6F	GG	142.60	139.88	154	70	85	100	—	24	70	7.60
34-14M-55	34	6F	GG	151.52	148.79	160	70	85	100	—	24	70	8.60
36-14M-55	36	6F	GG	160.43	157.68	168	70	85	100	—	24	70	9.60
38-14M-55	38	6F	GG	169.34	166.60	183	70	85	120	—	24	70	10.80
40-14M-55	40	6F	GG	178.25	175.49	188	70	85	120	—	24	70	11.20
44-14M-55	44	6F	GG	196.08	193.28	211	70	85	120	—	24	70	12.50
48-14M-55	48	10WF	GG	213.90	211.11	226	70	70	135	172	24	70	13.70
56-14M-55	56	10WF	GG	249.55	246.76	256	70	70	135	207	28	70	14.50
64-14M-55	64	10WF	GG	285.21	282.41	296	70	70	135	242	28	70	15.60
72-14M-55	72	10A	GG	320.86	318.06	—	70	70	135	278	28	70	18.50
80-14M-55	80	10A	GG	356.51	353.71	—	70	70	135	314	28	70	20.00
90-14M-55	90	10A	GG	401.07	398.28	—	70	70	135	358	28	70	22.60
112-14M-55*	112	10A	GG	499.11	496.32	—	70	70	135	456	28	70	29.50
144-14M-55*	144	10A	GG	641.71	638.92	—	70	70	135	600	28	70	39.00
168-14M-55*	168	10A	GG	748.66	745.87	—	70	70	135	706	28	70	48.50
192-14M-55*	192	10A	GG	855.62	852.82	—	70	70	135	813	28	70	57.80
216-14M-55*	216	10A	GG	962.57	959.77	—	70	70	150	920	28	80	67.00

GG = Grey cast iron * Non stock items Subject to production changes.

Timing Belt Pulleys

optibelt *ZRS HTD*[®] Timing Belt Pulleys for Cylindrical Bore

Section 14M



Power Transmission

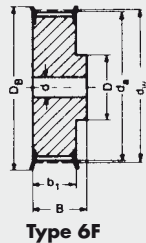

Type 6F

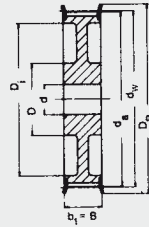

Type 10WF

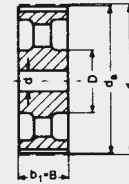

Type 10A

Section 14M – pitch 14 mm for belt width of 85 mm

Designation	Number of teeth	Type	Material	d_w [mm]	d_o [mm]	D_B [mm]	b_1 [mm]	B [mm]	D [mm]	D_i [mm]	Pilot bore d [mm]	Finish bore d_{max} [mm]	Weight ≈ [kg]
28-14M-85	28	6F	GG	124.78	122.12	127	102	117	100	—	24	60	7.70
29-14M-85	29	6F	GG	129.23	126.57	138	102	117	100	—	24	60	8.40
30-14M-85	30	6F	GG	133.69	130.99	138	102	117	100	—	24	60	9.10
32-14M-85	32	6F	GG	142.60	139.88	154	102	117	100	—	24	60	10.50
34-14M-85	34	6F	GG	151.52	148.79	160	102	117	100	—	24	70	11.90
36-14M-85	36	6F	GG	160.43	157.68	168	102	117	100	—	32	70	13.20
38-14M-85	38	6F	GG	169.34	166.60	183	102	117	120	—	32	70	15.15
40-14M-85	40	6F	GG	178.25	175.49	188	102	117	135	—	32	70	17.10
44-14M-85	44	6F	GG	196.08	193.28	211	102	117	135	—	32	70	23.30
48-14M-85	48	6F	GG	213.90	211.11	226	102	117	150	—	32	80	25.00
56-14M-85	56	10WF	GG	249.55	246.76	256	102	102	150	207	32	80	25.00
64-14M-85	64	10WF	GG	285.21	282.41	296	102	102	150	242	32	80	28.20
72-14M-85	72	10A	GG	320.86	318.06	—	102	102	150	278	32	80	28.80
80-14M-85	80	10A	GG	356.51	353.71	—	102	102	150	314	32	80	30.10
90-14M-85	90	10A	GG	401.07	398.28	—	102	102	150	358	32	80	33.00
112-14M-85*	112	10A	GG	499.11	496.32	—	102	102	150	456	32	80	41.80
144-14M-85*	144	10A	GG	641.71	638.92	—	102	102	150	600	32	80	52.40
168-14M-85*	168	10A	GG	748.66	745.87	—	102	102	150	706	32	80	60.30
192-14M-85*	192	10A	GG	855.62	852.82	—	102	102	165	813	32	90	70.20
216-14M-85*	216	10A	GG	962.57	959.77	—	102	102	165	920	32	90	81.00

Section 14M – pitch 14 mm for belt width of 115 mm

28-14M-115	28	6F	GG	124.78	122.12	127	133	148	100	—	32	60	9.20
29-14M-115	29	6F	GG	129.23	126.57	138	133	148	100	—	32	60	10.20
30-14M-115	30	6F	GG	133.69	130.99	138	133	148	100	—	32	60	11.20
32-14M-115	32	6F	GG	142.60	139.88	154	133	148	100	—	32	60	13.20
34-14M-115	34	6F	GG	151.52	148.79	160	133	148	100	—	32	70	14.80
36-14M-115	36	6F	GG	160.43	157.68	168	133	148	120	—	32	70	16.60
38-14M-115	38	6F	GG	169.34	166.60	183	133	148	120	—	32	70	19.20
40-14M-115	40	6F	GG	178.25	175.49	188	133	148	135	—	32	70	22.10
44-14M-115	44	6F	GG	196.08	193.28	211	133	148	140	—	32	80	28.00
48-14M-115	48	6F	GG	213.90	211.11	226	133	148	150	—	32	80	35.00
56-14M-115	56	6F	GG	249.55	246.76	256	133	148	150	—	32	80	44.20
64-14M-115	64	10WF	GG	285.21	282.41	296	133	133	150	242	32	80	36.80
72-14M-115	72	10A	GG	320.86	318.06	—	133	133	150	278	32	80	36.10
80-14M-115	80	10A	GG	356.51	353.71	—	133	133	150	314	32	80	38.60
90-14M-115	90	10A	GG	401.07	398.28	—	133	133	150	358	32	80	41.00
112-14M-115*	112	10A	GG	499.11	496.32	—	133	133	150	456	32	80	54.40
144-14M-115*	144	10A	GG	641.71	638.92	—	133	133	165	600	32	90	67.80
168-14M-115*	168	10A	GG	748.66	745.87	—	133	133	165	706	32	90	75.80
192-14M-115*	192	10A	GG	855.62	852.82	—	133	133	165	813	32	90	88.30
216-14M-115*	216	10A	GG	962.57	959.77	—	133	133	165	920	32	90	98.00

Timing Belt Pulleys

optibelt ZRS HTD® Timing Belt Pulleys for Cylindrical Bore

Section 14M



Power Transmission

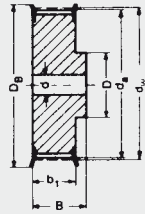

Type 6F

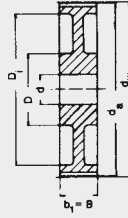

Type 10W

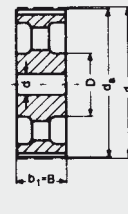

Type 10A

Section 14M – pitch 14 mm for belt width of 170 mm

Designation	Number of teeth	Type	Material	d_w [mm]	d_s [mm]	D_B [mm]	b_1 [mm]	B [mm]	D [mm]	D_1 [mm]	Pilot bore d [mm]	Finish bore d_{max} [mm]	Weight \approx [kg]
28-14M-170*	28	6F	GG	124.78	122.12	127	187	202	100	—	32	60	13.80
29-14M-170*	29	6F	GG	129.23	126.57	138	187	202	100	—	32	60	14.20
30-14M-170*	30	6F	GG	133.69	130.99	138	187	202	100	—	32	60	15.60
32-14M-170*	32	6F	GG	142.60	139.88	154	187	202	100	—	32	60	18.10
34-14M-170*	34	6F	GG	151.52	148.79	160	187	202	100	—	32	60	20.40
36-14M-170*	36	6F	GG	160.43	157.68	168	187	202	120	—	32	70	23.50
38-14M-170*	38	6F	GG	169.34	166.60	183	187	202	135	—	32	70	26.50
40-14M-170*	40	6F	GG	178.25	175.49	188	187	202	140	—	32	85	30.10
44-14M-170*	44	6F	GG	196.08	193.28	211	187	202	160	—	32	85	37.80
48-14M-170*	48	6F	GG	213.90	211.11	226	187	202	160	—	32	85	44.50
56-14M-170*	56	6F	GG	249.55	246.76	256	187	202	160	—	32	85	61.00
64-14M-170*	64	6F	GG	285.21	282.41	296	187	202	180	—	32	100	81.00
72-14M-170*	72	10W	GG	320.86	318.06	—	187	187	180	278	32	100	61.40
80-14M-170*	80	10W	GG	356.51	353.71	—	187	187	180	314	32	100	65.00
90-14M-170*	90	10A	GG	401.07	398.28	—	187	187	180	358	38	100	68.00
112-14M-170*	112	10A	GG	499.11	496.32	—	187	187	200	456	38	110	87.50
144-14M-170*	144	10A	GG	641.71	638.92	—	187	187	220	600	38	120	114.80
168-14M-170*	168	10A	GG	748.66	745.87	—	187	187	220	706	38	120	125.00
192-14M-170*	192	10A	GG	855.62	852.82	—	187	187	220	813	38	120	136.40
216-14M-170*	216	10A	GG	962.57	959.77	—	187	187	220	920	38	120	147.00

Timing Belt Pulleys

optibelt *ZRS HTD*[®] Timing Belt Pulleys for Taper Bushes

Section 5M



Power Transmission

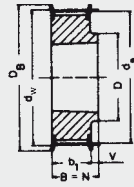

Type 8F

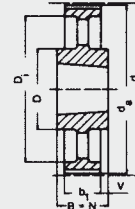

Type 7a

Section 5M – pitch 5 mm for belt width of 15 mm

Designation	Number of teeth	Type	Material	d_w [mm]	d_o [mm]	D_B [mm]	b_1 [mm]	B [mm]	N [mm]	V [mm]	Z [mm]	D [mm]	D_i [mm]	Taper bush	Weight without bush \approx [kg]
TB 34-5M-15	34	8F	St	54.11	52.97	57.0	20.5	22	22	1.5	—	43	—	1008	0.190
TB 36-5M-15	36	8F	St	57.30	56.16	60.0	20.5	22	22	1.5	—	44	—	1108	0.200
TB 38-5M-15	38	8F	St	69.48	59.34	66.0	20.5	22	22	1.5	—	48	—	1108	0.250
TB 40-5M-15	40	8F	St	63.66	62.52	71.0	20.5	22	22	1.5	—	52	—	1108	0.310
TB 44-5M-15	44	8F	St	70.03	68.89	75.0	20.5	22	22	1.5	—	54	—	1108	0.400
TB 48-5M-15	48	8F	St	76.39	75.25	83.0	20.5	25	25	4.5	—	64	—	1210	0.450
TB 56-5M-15	56	8F	GG	89.13	87.99	93.0	20.5	25	25	4.5	—	70	—	1210	0.670
TB 64-5M-15	64	8F	GG	101.86	100.72	106.0	20.5	25	25	4.5	—	78	—	1210	0.960
TB 72-5M-15	72	8F	GG	114.59	113.45	119.0	20.5	25	25	4.5	—	90	—	1610	1.190
TB 80-5M-15	80	8F	GG	127.32	126.18	135.0	20.5	25	25	4.5	—	92	—	1610	1.570
TB 90-5M-15	90	7A	GG	143.24	142.10	—	20.5	25	25	2.3	—	92	—	1610	1.147
TB 112-5M-15	112	7A	GG	178.25	177.11	—	20.5	25	25	2.3	—	92	—	1610	1.940
TB 136-5M-15	136	7A	GG	216.45	215.31	—	20.5	32	32	5.8	—	106	—	2012	3.060
TB 150-5M-15	150	7A	GG	238.73	237.59	—	20.5	32	32	5.8	—	106	—	2012	3.900

Taper bush	1008	1108	1210	1610	2012
Bore d_2 [mm] from ... to ...	10-25	10-28	11-32	14-42	14-50

 GG = Grey cast iron
 St = Steel

Subject to production changes.

 Bore diameter d_2 see page 68.

Timing Belt Pulleys

optibelt ZRS HTD® Timing Belt Pulleys for Taper Bushes

Section 8M



Power Transmission

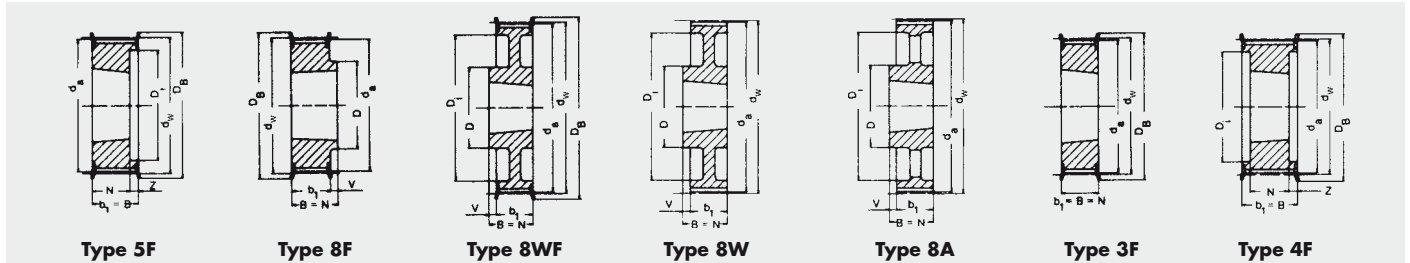

Section 8M – pitch 8 mm for belt width of 20 mm

Designation	Number of teeth	Type	Material	d _w [mm]	d _a [mm]	D _B [mm]	b ₁ [mm]	B [mm]	N [mm]	V [mm]	Z [mm]	D [mm]	D _i [mm]	Taper bush	Weight without bush ≈ [kg]
TB 22-8M-20	22	5F	GG	56.02	54.65	60.0	28	28	22	—	6	—	41	1008	0.24
TB 24-8M-20	24	5F	GG	61.12	59.75	66.0	28	28	22	—	6	—	42	1108	0.30
TB 26-8M-20	26	5F	GG	66.21	64.84	71.0	28	28	22	—	6	—	46	1108	0.36
TB 28-8M-20	28	5F	GG	71.30	69.93	75.0	28	28	22	—	6	—	50	1108	0.44
TB 30-8M-20	30	5F	GG	76.39	75.02	83.0	28	28	22	—	6	—	58	1108	0.53
TB 32-8M-20	32	5F	GG	81.49	80.12	87.0	28	28	25	—	3	—	62	1610	0.42
TB 34-8M-20	34	5F	GG	86.58	85.22	91.0	28	28	25	—	3	—	65	1610	0.55
TB 36-8M-20	36	5F	GG	91.67	90.30	98.5	28	28	25	—	3	—	68	1610	0.68
TB 38-8M-20	38	5F	GG	96.77	95.39	103.0	28	28	25	—	3	—	72	1610	0.80
TB 40-8M-20	40	5F	GG	101.86	100.49	106.0	28	28	25	—	3	—	76	1610	1.00
TB 44-8M-20	44	8F	GG	112.05	110.67	119.0	28	32	32	4	—	93	—	2012	1.20
TB 48-8M-20	48	8F	GG	122.23	120.86	127.0	28	32	32	4	—	96	—	2012	1.60
TB 56-8M-20	56	8F	GG	142.60	141.23	148.0	28	32	32	4	—	110	—	2012	2.40
TB 64-8M-20	64	8WF	GG	162.97	161.60	168.0	28	32	32	4	—	110	137	2012	2.70
TB 72-8M-20	72	8WF	GG	183.35	181.97	192.0	28	32	32	4	—	110	158	2012	3.30
TB 80-8M-20	80	8W	GG	203.72	202.35	—	28	32	32	4	—	110	180	2012	3.50
TB 90-8M-20	90	8A	GG	229.18	227.81	—	28	32	32	4	—	110	204	2012	3.65

Section 8M – pitch 8 mm for belt width of 30 mm

TB 22-8M-30	22	5F	GG	56.02	54.65	60.0	38	38	22	—	16	—	41	1008	0.29
TB 24-8M-30	24	5F	GG	61.12	59.75	66.0	38	38	22	—	16	—	42	1108	0.38
TB 26-8M-30	26	5F	GG	66.21	64.84	71.0	38	38	22	—	16	—	46	1108	0.45
TB 28-8M-30	28	5F	St	71.30	69.93	75.0	38	38	25	—	13	—	50	1210	0.50
TB 30-8M-30	30	3F	St	76.39	75.02	83.0	38	38	38	—	—	—	—	1615	0.45
TB 32-8M-30	32	3F	GG	81.49	80.12	87.0	38	38	38	—	—	—	—	1615	0.59
TB 34-8M-30	34	3F	GG	86.58	85.22	91.0	38	38	38	—	—	—	—	1615	0.77
TB 36-8M-30	36	3F	GG	91.67	90.30	98.5	38	38	38	—	—	—	—	1615	0.96
TB 38-8M-30	38	3F	GG	96.77	95.39	103.0	38	38	38	—	—	—	—	1615	1.15
TB 40-8M-30	40	3F	GG	101.86	100.49	106.0	38	38	38	—	—	—	—	1615	1.34
TB 44-8M-30	44	4F	GG	112.05	110.67	119.0	38	38	32	—	3	—	91	2012	1.33
TB 48-8M-30	48	4F	GG	122.23	120.86	127.0	38	38	32	—	3	—	95	2012	1.78
TB 56-8M-30	56	4F	GG	142.60	141.23	148.0	38	38	32	—	3	—	117	2012	3.76
TB 64-8M-30	64	8F	GG	162.97	161.60	168.0	38	45	45	7	—	125	—	2517	4.20
TB 72-8M-30	72	8WF	GG	183.35	181.97	192.0	38	45	45	7	—	125	158	2517	4.30
TB 80-8M-30	80	8W	GG	203.72	202.35	—	38	45	45	7	—	125	180	2517	4.60
TB 90-8M-30	90	8A	GG	229.18	227.81	—	38	45	45	7	—	125	204	2517	5.00
TB 112-8M-30	112	8A	GG	285.21	283.83	—	38	45	45	7	—	125	260	2517	6.20
TB 144-8M-30	144	8A	GG	366.69	365.32	—	38	45	45	7	—	125	341	2517	9.00

GG = Grey cast iron
Subject to production changes.

Taper bush	1008	1108	1210	1610	1615	2012	2517
Bore d ₂ [mm] from ... to ...	10-25	10-28	11-32	14-42	14-42	14-50	16-60

Bore diameter d₂ see page 68.

Timing Belt Pulleys

optibelt *ZRS HTD*[®] Timing Belt Pulleys for Taper Bushes

Section 8M



Power Transmission

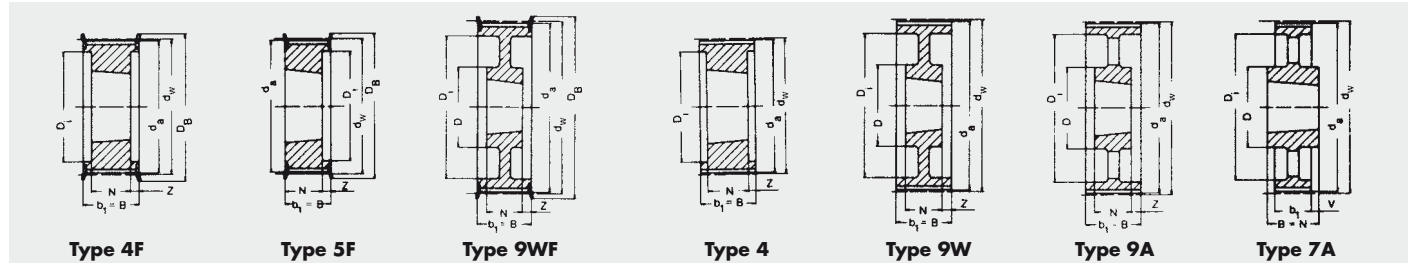

Section 8M – pitch 8 mm for belt width of 50 mm

Designation	Number of teeth	Type	Material	d_w [mm]	d_o [mm]	D_B [mm]	b_1 [mm]	B [mm]	N [mm]	V [mm]	Z [mm]	D [mm]	D_i [mm]	Taper bush	Weight without bush ≈ [kg]
TB 28-8M-50	28	5F	St	71.30	69.93	75.0	60	60	25	—	35.0	—	50	1210	0.60
TB 30-8M-50	30	5F	St	76.39	75.02	83.0	60	60	38	—	22.0	—	58	1615	0.65
TB 32-8M-50	32	5F	GG	81.49	80.12	87.0	60	60	38	—	22.0	—	62	1615	0.82
TB 34-8M-50	34	5F	GG	86.58	85.22	91.0	60	60	38	—	22.0	—	65	1615	1.06
TB 36-8M-50	36	5F	GG	91.67	90.30	98.5	60	60	38	—	22.0	—	68	1615	1.30
TB 38-8M-50	38	5F	GG	96.77	95.39	103.0	60	60	38	—	22.0	—	72	1615	1.60
TB 40-8M-50	40	4F	GG	101.86	100.49	106.0	60	60	32	—	14.0	—	82	2012	1.71
TB 44-8M-50	44	4F	GG	112.05	110.67	119.0	60	60	32	—	14.0	—	91	2012	1.78
TB 48-8M-50	48	4F	GG	122.23	120.86	127.0	60	60	32	—	14.0	—	95	2012	2.30
TB 56-8M-50	56	4F	GG	142.60	141.23	148.0	60	60	45	—	7.5	—	116	2517	3.40
TB 64-8M-50	64	4F	GG	162.97	161.60	168.0	60	60	45	—	7.5	—	137	2517	5.00
TB 72-8M-50	72	9WF	GG	183.35	181.97	192.0	60	60	45	—	7.5	125	158	2517	6.70
TB 80-8M-50	80	4	GG	203.72	202.35	—	60	60	51	—	4.5	—	180	3020	8.80
TB 90-8M-50	90	9W	GG	229.18	227.81	—	60	60	51	—	4.5	170	204	3020	10.00
TB 112-8M-50	112	9W	GG	285.21	283.83	—	60	60	51	—	4.5	170	260	3020	12.00
TB 144-8M-50	144	9A	GG	366.69	365.32	—	60	60	51	—	4.5	170	341	3020	15.20
TB 168-8M-50	168	7A	GG	427.81	426.44	—	60	65	65	—	2.5	170	402	3525	16.40
TB 192-8M-50	192	7A	GG	488.92	487.55	—	60	65	65	—	2.5	170	460	3525	21.80

Section 8M – pitch 8 mm for belt width of 85 mm

TB 34-8M-85	34	4F	GG	86.58	85.22	91.0	95	95	38	—	28.5	—	65	1615	1.43
TB 36-8M-85	36	4F	GG	91.67	90.30	98.5	95	95	38	—	28.5	—	68	1615	1.87
TB 38-8M-85	38	4F	GG	96.77	95.39	103.0	95	95	38	—	28.5	—	72	1615	2.20
TB 40-8M-85	40	4F	GG	101.86	100.49	106.0	95	95	32	—	31.5	—	82	2012	1.78
TB 44-8M-85	44	4F	GG	112.05	110.67	119.0	95	95	32	—	31.5	—	91	2012	2.30
TB 48-8M-85	48	4F	GG	122.23	120.86	127.0	95	95	45	—	25.0	—	100	2517	2.66
TB 56-8M-85	56	4F	GG	142.60	141.23	148.0	95	95	45	—	25.0	—	117	2517	4.45
TB 64-8M-85	64	4F	GG	162.97	161.60	168.0	95	95	45	—	25.0	—	137	2517	6.20
TB 72-8M-85	72	4F	GG	183.35	181.97	192.0	95	95	51	—	22.0	—	158	3020	8.00
TB 80-8M-85	80	4	GG	203.72	202.35	—	95	95	51	—	22.0	—	180	3020	10.00
TB 90-8M-85	90	9W	GG	229.18	227.81	—	95	95	51	—	22.0	170	204	3020	10.80
TB 112-8M-85	112	9W	GG	285.21	283.83	—	95	95	51	—	22.0	170	260	3020	15.00
TB 144-8M-85	144	9A	GG	366.69	365.32	—	95	95	76	—	15.0	170	341	3525	20.00
TB 168-8M-85	168	9A	GG	427.81	426.44	—	95	95	76	—	15.0	170	402	3525	23.00
TB 192-8M-85	192	9A	GG	488.92	487.55	—	95	95	76	—	15.0	170	460	3525	28.50

Taper bush	1210	1615	2012	2517	3020	3525
Bore d_2 [mm] from ... to ...	11-32	14-42	14-50	16-60	25-75	35-90

 GG = Grey cast iron
 Subject to production changes.

 Bore diameter d_2 see page 68.

Timing Belt Pulleys

optibelt ZRS HTD® Timing Belt Pulleys for Taper Bushes

Section 14M



Power Transmission

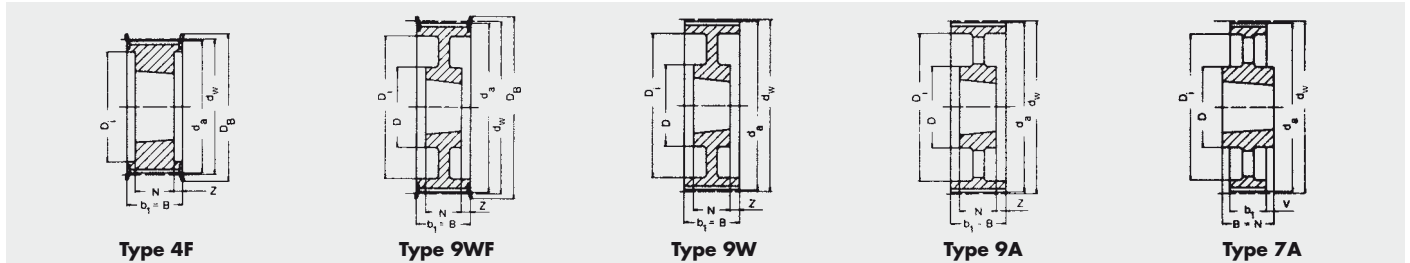

Section 14M – pitch 14 mm for belt width of 40 mm

Designation	Number of teeth	Type	Material	d_w [mm]	d_a [mm]	D_B [mm]	b_1 [mm]	B [mm]	N [mm]	V [mm]	Z [mm]	D [mm]	D_i [mm]	Taper bush	Weight without bush ≈ [kg]
TB 28-14M-40	28	4F	GG	124.78	122.12	127	54	54	32	—	11.0	—	98	2012	2.00
TB 29-14M-40	29	4F	GG	129.23	126.57	138	54	54	32	—	11.0	—	100	2012	2.38
TB 30-14M-40	30	4F	GG	133.69	130.99	138	54	54	32	—	11.0	—	100	2012	2.65
TB 32-14M-40	32	4F	GG	142.60	139.88	154	54	54	32	—	11.0	—	104	2012	3.40
TB 34-14M-40	34	4F	GG	151.52	148.79	160	54	54	45	—	4.5	—	110	2517	3.87
TB 36-14M-40	36	4F	GG	160.43	157.68	168	54	54	45	—	4.5	—	120	2517	4.80
TB 38-14M-40	38	4F	GG	169.34	166.60	183	54	54	45	—	4.5	—	130	2517	5.40
TB 40-14M-40	40	4F	GG	178.25	175.49	188	54	54	45	—	4.5	—	138	2517	6.00
TB 44-14M-40	44	4F	GG	196.08	193.28	211	54	54	51	—	1.5	—	155	3020	7.80
TB 48-14M-40	48	4F	GG	213.90	211.11	226	54	54	51	—	1.5	—	170	3020	9.40
TB 56-14M-40	56	9WF	GG	249.55	246.76	256	54	54	51	—	1.5	170	208	3020	10.80
TB 64-14M-40	64	9WF	GG	285.21	282.41	296	54	54	51	—	1.5	170	242	3020	13.40
TB 72-14M-40	72	9W	GG	320.86	318.06	—	54	54	51	—	1.5	170	280	3020	15.20
TB 80-14M-40	80	9A	GG	356.51	353.71	—	54	54	51	—	1.5	170	315	3020	16.00
TB 90-14M-40	90	9A	GG	401.07	398.28	—	54	54	51	—	1.5	170	360	3020	17.80
TB 112-14M-40	112	9A	GG	499.11	496.32	—	54	54	51	—	1.5	170	457	3020	25.60
TB 144-14M-40	144	9A	GG	641.71	638.92	—	54	54	51	—	1.5	170	600	3020	32.00
TB 168-14M-40	168	9A	GG	748.66	745.87	—	54	54	51	—	1.5	170	706	3020	44.00
TB 192-14M-40	192	9A	GG	855.62	852.82	—	54	54	51	—	1.5	170	813	3020	49.00
TB 216-14M-40	216	9A	GG	962.57	959.77	—	54	54	51	—	1.5	170	920	3020	55.00

Section 14M – pitch 14 mm for belt width of 55 mm

TB 28-14M-55	28	4F	GG	124.78	122.12	127	70	70	32	—	19.0	—	98	2012	2.20
TB 29-14M-55	29	4F	GG	129.23	126.57	138	70	70	32	—	19.0	—	100	2012	2.74
TB 30-14M-55	30	4F	GG	133.69	130.99	138	70	70	45	—	12.5	—	100	2517	2.70
TB 32-14M-55	32	4F	GG	142.60	139.88	154	70	70	45	—	12.5	—	108	2517	3.66
TB 34-14M-55	34	4F	GG	151.52	148.79	160	70	70	45	—	12.5	—	110	2517	4.55
TB 36-14M-55	36	4F	GG	160.43	157.68	168	70	70	45	—	12.5	—	120	2517	5.20
TB 38-14M-55	38	4F	GG	169.34	166.60	183	70	70	45	—	12.5	—	130	2517	6.20
TB 40-14M-55	40	4F	GG	178.25	175.49	188	70	70	45	—	12.5	—	138	2517	7.00
TB 44-14M-55	44	4F	GG	196.08	193.28	211	70	70	51	—	9.5	—	155	3020	8.60
TB 48-14M-55	48	4F	GG	213.90	211.11	226	70	70	51	—	9.5	—	170	3020	10.40
TB 56-14M-55	56	9WF	GG	249.55	246.76	256	70	70	51	—	9.5	170	208	3020	12.00
TB 64-14M-55	64	9WF	GG	285.21	282.41	296	70	70	51	—	9.5	170	242	3020	14.50
TB 72-14M-55	72	9W	GG	320.86	318.06	—	70	70	51	—	9.5	170	280	3020	16.20
TB 80-14M-55	80	9A	GG	356.51	353.71	—	70	70	51	—	9.5	170	315	3020	17.50
TB 90-14M-55	90	9A	GG	401.07	398.28	—	70	70	51	—	9.5	170	360	3020	20.10
TB 112-14M-55	112	9A	GG	499.11	496.32	—	70	70	51	—	9.5	170	457	3020	28.40
TB 144-14M-55	144	9A	GG	641.71	638.92	—	70	70	51	—	9.5	170	600	3020	36.20
TB 168-14M-55	168	9A	GG	748.66	745.87	—	70	70	51	—	9.5	170	706	3020	49.00
TB 192-14M-55	192	9A	GG	855.62	852.82	—	70	70	51	—	9.5	170	813	3020	53.00
TB 216-14M-55	216	7A	GG	962.57	959.77	—	70	89	89	9.5	—	190	920	3535	65.80

Taper bush	2012	2517	3020	3535
Bore d_2 [mm] from ... to ...	14-50	16-60	25-75	35-90

GG = Grey cast iron
Subject to production changes.

Bore diameter d_2 see page 68.

Timing Belt Pulleys

optibelt *ZRS HTD*[®] Timing Belt Pulleys for Taper Bushes

Section 14M



Power Transmission

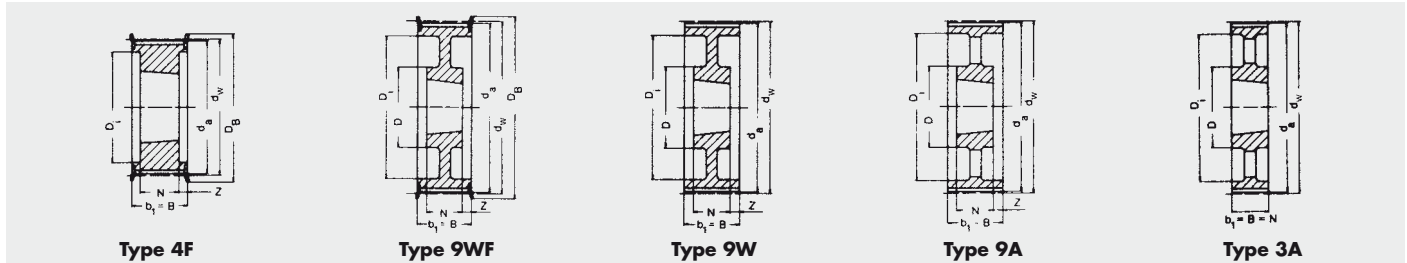

Section 14M – pitch 14 mm for belt width of 85 mm

Designation	Number of teeth	Type	Material	d _w [mm]	d _o [mm]	D _B [mm]	b ₁ [mm]	B [mm]	N [mm]	V [mm]	Z [mm]	D [mm]	D _i [mm]	Taper bush	Weight without bush ≈ [kg]
TB 28-14M-85	28	4F	GG	124.78	122.12	127	102	102	45	—	28.5	—	98	2517	2.70
TB 29-14M-85	29	4F	GG	129.23	126.57	138	102	102	45	—	28.5	—	100	2517	3.40
TB 30-14M-85	30	4F	GG	133.69	130.99	138	102	102	45	—	28.5	—	100	2517	3.75
TB 32-14M-85	32	4F	GG	142.60	139.88	154	102	102	45	—	28.5	—	108	2517	4.80
TB 34-14M-85	34	4F	GG	151.52	148.79	160	102	102	45	—	28.5	—	110	2517	6.00
TB 36-14M-85	36	4F	GG	160.43	157.68	168	102	102	51	—	25.5	—	120	3020	5.80
TB 38-14M-85	38	4F	GG	169.34	166.60	183	102	102	51	—	25.5	—	130	3020	6.80
TB 40-14M-85	40	4F	GG	178.25	175.49	188	102	102	51	—	25.5	—	138	3020	8.00
TB 44-14M-85	44	4F	GG	196.08	193.28	211	102	102	76	—	13.0	—	155	3030	11.80
TB 48-14M-85	48	4F	GG	213.90	211.11	226	102	102	76	—	13.0	—	170	3030	15.10
TB 56-14M-85	56	4F	GG	249.55	246.76	256	102	102	65	—	18.5	190	210	3525	19.00
TB 64-14M-85	64	9WF	GG	285.21	282.41	296	102	102	65	—	18.5	190	242	3525	23.00
TB 72-14M-85	72	9W	GG	320.86	318.06	—	102	102	65	—	18.5	190	280	3525	25.00
TB 80-14M-85	80	9A	GG	356.51	353.71	—	102	102	65	—	18.5	190	315	3525	26.00
TB 90-14M-85	90	9A	GG	401.07	398.28	—	102	102	65	—	18.5	190	360	3525	27.80
TB 112-14M-85	112	9A	GG	499.11	496.32	—	102	102	65	—	18.5	190	457	3525	36.50
TB 144-14M-85	144	9A	GG	641.71	638.92	—	102	102	65	—	18.5	190	600	3525	48.00
TB 168-14M-85	168	9A	GG	748.66	745.87	—	102	102	65	—	18.5	190	706	3525	60.00
TB 192-14M-85	192	3A	GG	855.62	852.82	—	102	102	102	—	—	230	813	4040	86.00
TB 216-14M-85	216	3A	GG	962.57	959.77	—	102	102	102	—	—	230	920	4040	91.50

Section 14M – pitch 14 mm for belt width of 115 mm

TB 28-14M-115	28	4F	GG	124.78	122.12	127	133	133	45	—	44.0	—	98	2517	3.77
TB 29-14M-115	29	4F	GG	129.23	126.57	138	133	133	45	—	44.0	—	100	2517	4.00
TB 30-14M-115	30	4F	GG	133.69	130.99	138	133	133	45	—	44.0	—	100	2517	5.00
TB 32-14M-115	32	4F	GG	142.60	139.88	154	133	133	45	—	44.0	—	108	2517	6.80
TB 34-14M-115	34	4F	GG	151.52	148.79	160	133	133	45	—	44.0	—	110	2517	6.80
TB 36-14M-115	36	4F	GG	160.43	157.68	168	133	133	51	—	41.0	—	120	3020	7.00
TB 38-14M-115	38	4F	GG	169.34	166.60	183	133	133	51	—	41.0	—	130	3020	8.40
TB 40-14M-115	40	4F	GG	178.25	175.49	188	133	133	51	—	41.0	—	140	3020	9.20
TB 44-14M-115	44	4F	GG	196.08	193.28	211	133	133	76	—	28.5	—	155	3030	14.00
TB 48-14M-115	48	4F	GG	213.90	211.11	226	133	133	76	—	28.5	—	170	3030	17.10
TB 56-14M-115	56	4F	GG	249.55	246.76	256	133	133	89	—	22.0	—	210	3535	24.80
TB 64-14M-115	64	9WF	GG	285.21	282.41	296	133	133	89	—	22.0	190	242	3535	27.00
TB 72-14M-115	72	9W	GG	320.86	318.06	—	133	133	89	—	22.0	190	280	3535	29.00
TB 80-14M-115	80	9A	GG	356.51	353.71	—	133	133	89	—	22.0	190	315	3535	32.00
TB 90-14M-115	90	9A	GG	401.07	398.28	—	133	133	89	—	22.0	190	360	3535	36.50
TB 112-14M-115	112	9A	GG	499.11	496.32	—	133	133	89	—	22.0	190	457	3535	46.00
TB 144-14M-115	144	9A	GG	641.71	638.92	—	133	133	102	—	15.5	230	600	4040	68.00
TB 168-14M-115	168	9A	GG	748.66	745.87	—	133	133	102	—	15.5	230	706	4040	82.60
TB 192-14M-115	192	9A	GG	855.62	852.82	—	133	133	102	—	15.5	230	813	4040	96.00
TB 216-14M-115	216	9A	GG	962.57	959.77	—	133	133	102	—	15.5	230	920	4040	107.00

Taper bush	2517	3020	3030	3525	3535	4040
Bore d ₂ [mm] from ... to ...	16-60	25-75	35-75	35-90	35-90	40-100

GG = Grey cast iron
Subject to production changes.

Bore diameter d₂ see page 68.

Timing Belt Pulleys

optibelt ZRS HTD® Timing Belt Pulleys for Taper Bushes

Section 14M

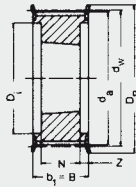
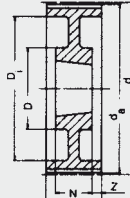
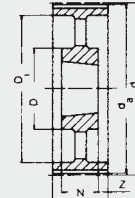

Power Transmission

Type 4F

Type 9W

Type 9A

Section 14M – pitch 14 mm for belt width of 170 mm

Designation	Number of teeth	Type	Material	d_w [mm]	d_o [mm]	D_B [mm]	b_1 [mm]	B [mm]	N [mm]	V [mm]	Z [mm]	D [mm]	D_i [mm]	Taper bush	Weight without bush ≈ [kg]
TB 38-14M-170*	38	4F	GG	169.34	166.60	183	187	187	76	—	55.5	—	130	3030	11.70
TB 40-14M-170*	40	4F	GG	178.25	175.49	188	187	187	76	—	55.5	—	140	3030	13.00
TB 44-14M-170*	44	4F	GG	196.08	193.28	211	187	187	89	—	49.0	—	155	3535	15.00
TB 48-14M-170*	48	4F	GG	213.90	211.11	226	187	187	89	—	49.0	—	175	3535	19.00
TB 56-14M-170*	56	4F	GG	249.55	246.76	256	187	187	89	—	49.0	—	210	3535	28.50
TB 64-14M-170*	64	4F	GG	285.21	282.41	296	187	187	102	—	42.5	—	240	4040	41.00
TB 72-14M-170*	72	9W	GG	320.86	318.06	—	187	187	102	—	42.5	230	280	4040	46.90
TB 80-14M-170*	80	9W	GG	356.51	353.71	—	187	187	102	—	42.5	230	315	4040	48.00
TB 90-14M-170*	90	9A	GG	401.07	398.28	—	187	187	102	—	42.5	230	360	4040	52.50
TB 112-14M-170*	112	9A	GG	499.11	496.32	—	187	187	127	—	30.0	265	457	5050	74.50
TB 144-14M-170*	144	9A	GG	641.71	638.92	—	187	187	127	—	30.0	265	600	5050	91.00
TB 168-14M-170*	168	9A	GG	748.66	745.87	—	187	187	127	—	30.0	265	706	5050	116.00
TB 192-14M-170*	192	9A	GG	855.62	852.82	—	187	187	127	—	30.0	265	813	5050	134.00
TB 216-14M-170*	216	9A	GG	962.57	959.77	—	187	187	127	—	30.0	265	920	5050	146.50

Taper bush	3030	3535	4040	5050
Bore d_2 [mm] from ... to ...	35-75	35-90	40-100	70-125

GG = Grey cast iron
 Subject to production changes.
 * Non stock items
 Bore diameter d_2 see page 68.

Timing Belt Pulleys

optibelt TB Taper Bushes



Taper bushes with metric bore, keyway to DIN 6885 part 1

	Taper bush										Material: EN-GJL-200 – DIN EN 1561					
	1008	1108	1210	1215	1310	1610	1615	2012	2517	3020	3030	3525	3535	4040	4545	5050
Bore diameter d_2 [mm]	10	10	11	11	14	14	14	14	16	25	35	35	35	40	55	70
	11	11	12	12	16	16	16	16	18	28	38	38	38	42	60	75
	12	12	14	14	18	18	18	18	19	30	40	40	40	45	65	80
	14	14	16	16	19	19	19	19	20	32	42	42	42	48	70	85
	16	16	18	18	20	20	20	20	22	35	45	45	45	50	75	90
	18	18	19	19	22	22	22	22	24	38	48	48	48	55	80	95
	19	19	20	20	24	24	24	24	25	40	50	50	50	60	85	100
	20	20	22	22	25	25	25	25	28	42	55	55	55	65	90	105
	22	22	24	24	28	28	28	28	30	45	60	60	60	70	95	110
	24▲	24	25	25	30	30	30	30	32	48	65	65	65	75	100	115
	25▲	25	28	28	32	32	32	32	35	50	70	70	70	80	105	120
		28▲	30	30	35	35	35	35	38	55	75	75	75	85	110	125
			32	32		38	38	38	40	60		80	80	90		
						40	40	40	42	65		85	85	95		
						42▲	42▲	42	45	70		90	90	100		
								45	48	75						
								48	50							
								50	55							
								60	60							
Hexagon socket screws [inch]	1/4 x 1/2	1/4 x 1/2	3/8 x 5/8	3/8 x 5/8	3/8 x 5/8	3/8 x 5/8	3/8 x 5/8	7/16 x 7/8	1/2 x 1	5/8 x 1 1/4	5/8 x 1 1/4	1/2 x 1 1/2	1/2 x 1 1/2	5/8 x 1 3/4	3/4 x 2	7/8 x 2 1/4
Tightening torque [Nm]	5.7	5.7	20	20	20	20	20	31	49	92	92	115	115	172	195	275
Bush length [mm]	22.3	22.3	25.4	38.1	25.4	25.4	38.1	31.8	44.5	50.8	76.2	63.5	88.9	101.6	114.3	127.0
Weight at $d_{2\min} \approx$ [kg]	0.12	0.16	0.28	0.39	0.32	0.41	0.60	0.75	1.06	2.50	3.75	3.90	5.13	7.68	12.70	15.17

From 3525: Hexagon head screw ▲ These bores have shallow keyways.

Shallow keyways for taper bushes

Bore diameter d_2 [mm]	Keyway width b [mm]	Keyway depth t_2 [mm]	Bore diameter d_2 [mm]	Keyway width b [mm]	Keyway depth t_2 [mm]
24	8	2.0	28	8	2.0
25	8	1.3	42	12	2.2

Taper bushes with inch bore, keyway to British Standard BS 46 part 1

	Taper bush										Material: EN-GJL-200 – DIN EN 1561					
	1008	1108	1210	1215	1310	1610	1615	2012	2517	3020	3030	3525	3535	4040	4545	5050
Bore diameter d_2 [inch]	3/8*	3/8*	1/2	5/8*	1/2*	1/2	1/2	5/8*	3/4	1 1/4	1 1/4	1 1/2	1 1/2	1 3/4*	2 1/4*	3*
	1/2	1/2	5/8	3/4	5/8*	5/8	5/8	3/4	7/8	1 3/8	1 3/8	1 5/8	1 5/8	1 7/8*	2 3/8*	3 1/4*
	5/8	5/8	3/4	7/8	3/4*	3/4	3/4	7/8	1	1 1/2	1 1/2	1 3/4	1 3/4	2*	2 1/2*	3 1/2*
	3/4	3/4	7/8	1	7/8*	7/8	7/8*	1	1 1/8	1 5/8	1 5/8	1 7/8	1 7/8	2 1/8*	2 3/4*	3 3/4*
	7/8	7/8	1	1 1/8	1*	1	1	1 1/8	1 1/4	1 3/4*	1 3/4*	2	2	2 1/4*	2 7/8*	4*
	1▲	1	1 1/8	1 1/4	1 1/8	1 1/8	1 1/8	1 1/4	1 3/8	1 7/8	1 7/8	2 1/8	2 1/8	2 3/8*	3*	4 1/4*
		1 1/8▲*	1 1/4		1 1/4	1 1/4	1 1/4	1 3/8	1 1/2	2	2	2 1/4	2 1/4	2 1/2*	3 1/4*	4 1/2*
					1 3/8	1 3/8	1 3/8	1 1/2	1 5/8	2 1/8*	2 1/8*	2 3/8	2 3/8	2 5/8*	3 3/8*	4 3/4*
					1 1/2	1 1/2	1 1/2	1 5/8	1 3/4	2 1/4	2 1/4	2 1/2	2 1/2	2 3/4*	3 1/2*	5▲*
					1 5/8	1 5/8	1 5/8	1 3/4	1 7/8	2 3/8	2 3/8	2 5/8	2 5/8	2 7/8*	3 3/4*	
								1 7/8	2	2 1/2	2 1/2	2 3/4	2 3/4	3*	4*	
								2	2 1/8	2 5/8	2 5/8*	2 7/8	2 7/8	3 1/8*	4 1/4▲*	
								2 3/8	2 3/4	2 7/8	2 7/8	3	3	3 1/4*	4 1/2▲*	
								2 1/2	3	3	3	3 1/4	3 1/4	3 1/2*		
												3 3/8	3 3/8	3 3/4▲*		
												3 1/2▲	3 1/2▲	4▲*		
Hexagon socket screws [inch]	1/4 x 1/2	1/4 x 1/2	3/8 x 5/8	3/8 x 5/8	3/8 x 5/8	3/8 x 5/8	3/8 x 5/8	7/16 x 7/8	1/2 x 1	5/8 x 1 1/4	5/8 x 1 1/4	1/2 x 1 1/2	1/2 x 1 1/2	5/8 x 1 3/4	3/4 x 2	7/8 x 2 1/4
Tightening torque [Nm]	5.7	5.7	20	20	20	20	20	31	49	92	92	115	115	172	195	275
Bush length [mm]	22.3	22.3	25.4	38.1	25.4	25.4	38.1	31.8	44.5	50.8	76.2	63.5	88.9	101.6	114.3	127.0
Weight at $d_{2\min} \approx$ [kg]	0.12	0.16	0.28	0.39	0.32	0.41	0.60	0.75	1.06	2.50	3.75	3.90	5.13	7.68	12.70	15.17

Timing Belt Pulleys

Recommended Special Constructions

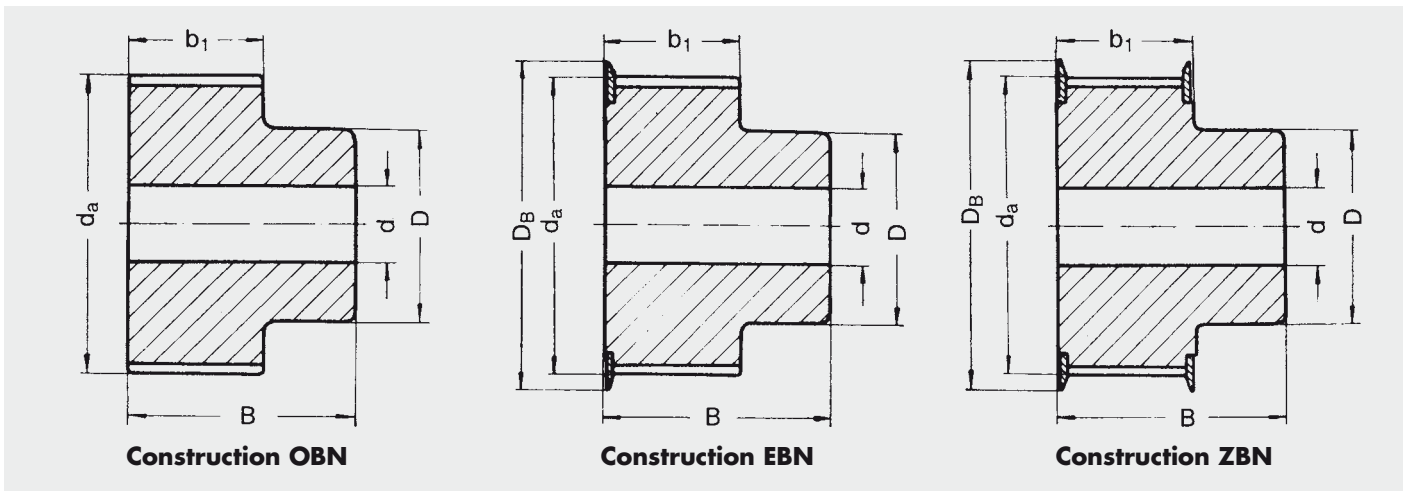
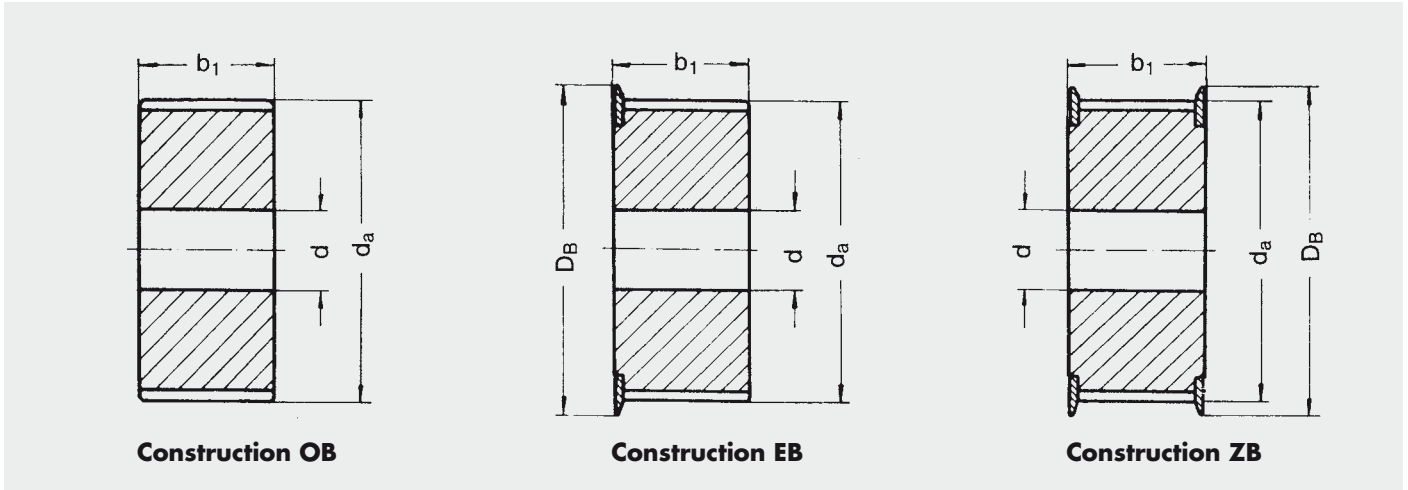

Materials

Steel, grey cast iron, aluminium;
 other materials available on request
 Do NOT use cast iron for speeds > 30 m/s
 anymore!

Bores

All timing pulleys are pilot bored. On request they can be finish bored to DIN H7 tolerance.

Explanation of the abbreviations

- OB = without flanges
- EB = one flange
- ZB = two flanges
- OBN = without flanges, with hub
- EBN = one flange, with hub
- ZBN = two flanges, with hub

Timing Belt Pulleys

Dimensions and Tolerances



Power Transmission

Permissible variation in tooth pitch

The permissible variations in tooth pitch between two consecutive teeth and for the sum of the variations within a 90° arc of a pulley are shown in the following table. These tolerances indicate the distance between the corresponding points on the right or the left flank of consecutive teeth.

Outside diameter d_a [mm]	Permissible variation in tooth pitch [mm]	
	between two consecutive teeth	sum within a 90° arc
≤ 25	0.03	0.06
> 25 ≤ 50	0.03	0.09
> 50 ≤ 100	0.03	0.10
> 100 ≤ 175	0.03	0.13
> 175 ≤ 300	0.03	0.15
> 300 ≤ 500	0.03	0.18
> 500	0.03	0.20

Permissible variation of the outside diameter

Outside diameter d_a [mm]	Permissible variation [mm]
≤ 25	+ 0.05 0
> 25 ≤ 50	+ 0.07 0
> 50 ≤ 100	+ 0.10 0
> 100 ≤ 175	+ 0.13 0
> 175 ≤ 300	+ 0.15 0
> 300 ≤ 500	+ 0.18 0
> 500	+ 0.20 0

Pulley width

Section	Pulley- width- designation [mm]	Nominal pulley width [mm]	Smallest pulley width with flanges b_f^* [mm]	without flanges b [mm]
3 M	6	6	7	9
	9	9	10	12
	15	15	17	19
5 M	9	9	10	12
	15	15	17	19
	25	25	27	29
8 M	20	20	22	26
	30	30	34	38
	50	50	54	58
	85	85	90	94
14 M	40	40	47	54
	55	55	63	70
	85	85	95	102
	115	115	126	133
	170	170	180	187

* b_f = pulley width between the flanges

Note

The minimum width b for pulleys without flanges can be reduced, if there is no side wobble or run out; however, it may not fall below the minimum width b_f for pulleys with flanges.

Axial run out tolerance

Outside diameter range [mm]	Maximum overall fluctuation [mm]
≤ 100	0.10
> 100 ≤ 250	0.01 mm per 10 mm outside diameter
> 250	0.25 mm + 0.0005 mm per mm outside diameter over 250.00 mm

Tolerance of eccentricity

Outside diameter range [mm]	Maximum overall fluctuation [mm]
≤ 200	0.10
> 200	0.0005 mm per 10 mm outside diameter, but not exceeding the tolerance for the outside diameter

Timing Belt Pulleys

Dimensions and Tolerances



Balancing

Steel pulleys that have been machined on all sides do not need to be balanced if the circumferential speed is below 30 m/s. Grey cast iron pulleys for medium speeds should be statically balanced as follows:

Section	Number of teeth	Static balance [N]
3M	all	0.04
5M	all	0.08
8M	≤ 130	0.08
	> 130	0.16
14M	≤ 72	0.08
	> 72	0.16

Pulleys which are used for circumferential speeds in excess of 30 m/s, must be balanced dynamically to $1.8 \cdot 10^{-5}$ Nm.

Parallelism

The teeth are to be aligned in parallel to the axis of the bore, with a variation of no more than 0.001 mm per millimetre width.

Taper

The taper across the pulley face may not exceed 0.001 mm per millimetre of the face width and at the same time may not exceed the permissible outside diameter tolerance.

Design Hints

Flanged Timing Belt Pulleys / Tension Idlers



Power Transmission

Flanged timing belt pulleys

For the guidance of timing belts, the pulleys should be equipped with flanges on one or both sides.

With centre distances of $\geq 8 d_{wk}$ the pulleys should have flanges on both sides.

We recommend the use of standard pulleys. If this is not possible due to the machine construction, pulleys specially designed for the machine may be used.

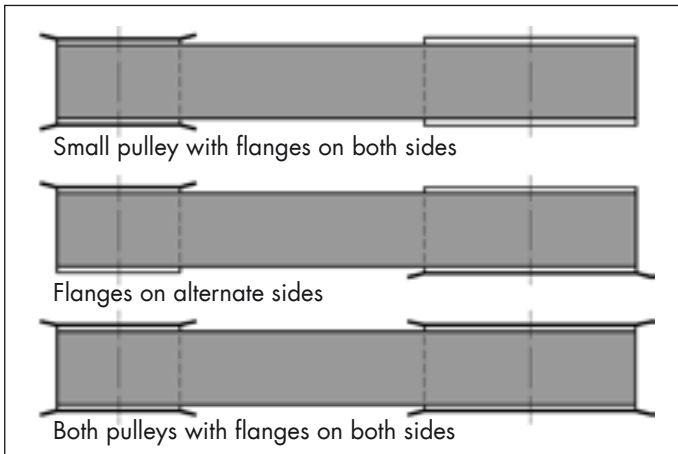

Maximum timing belt width

The maximum timing belt width should not exceed the diameter of the smallest pulley in the drive.

Tension idlers

Idlers are timing belt or flat pulleys, that play no part in power transmission within a drive system. Because they generate additional bending stresses in the belt, they should be used in accordance with the following guidelines:

- Diameter of the tension idlers \geq the smallest recommended pulley diameter for the belt section
- Width of the tension idlers \geq width of the timing pulleys in the drive
- Always position the tension idlers in the slack side of the drive
- Inside idlers:
 - ≤ 40 teeth, always use a timing belt pulley
 - > 40 teeth, a flat faced idler is permissible
- In general, outside idlers should always be flat faced as they run on the top surface of the belt
- Crowned idlers should never be used
- Fit the tension idlers in such a way as to enable as many teeth as possible to mesh with the small pulley
- Keep the arc of contact on the tension idler as small as possible

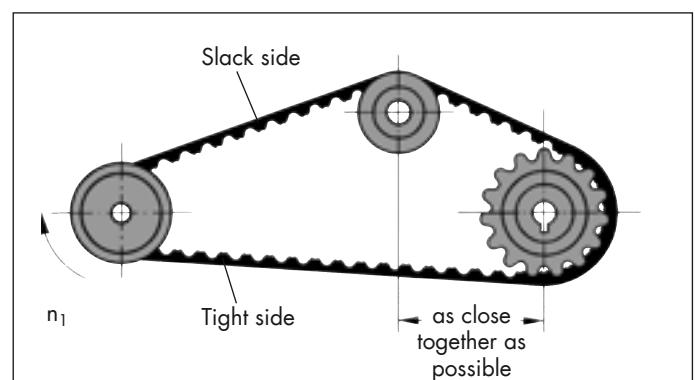
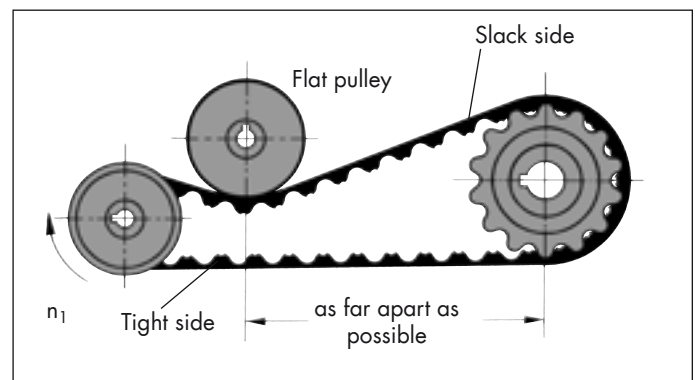

Design Hints

Installation and Maintenance



Safety information

Correctly designed drives with regard to geometry and power with Optibelt timing belts ensure a high level of operational safety and optimum service life.

Experience shows that unsatisfactory service life is often attributable to errors in installation and maintenance. In order to avoid this, we suggest that you observe the following recommendations.

- **Timing pulleys**

The teeth must conform to the appropriate standards and should be clean.

- **Alignment**

Shafts and pulleys should be aligned prior to the assembly.

Maximum deviations of the shaft parallelism:

Belt widths [mm]	Shaft misalignment
≤ 25	± 1°
> 25 ≤ 50	± 0.5°
> 50 ≤ 100	± 0.25°
> 100	± 0.15°

- **Timing belt sets**

Timing belts which run on a drive in pairs or in sets of several belts must be ordered in sets in all cases. This is to ensure that all belts come from the same manufacturing sleeve and have an identical length.

- **Assembly**

Prior to the assembly, the centre distance is to be reduced in such a way that the timing belt may be fitted without force. If this is not possible, the timing belt must be installed together with one or both pulleys. Installation with the use of force is NOT permissible at any time as this can damage the high quality, low-stretch tension cord and other components. This damage is often not visible.

When using taper bushes, the socket screws should be checked again after 0.5-1 hour running time using a torque wrench. Starting torques see page 68.

- **Belt tension**

The belt tension is to be applied in accordance with the guidelines on page 34. Further checks after installation are not necessary.

- **Tension idlers**

Avoid tension idlers. If this is not possible, follow our recommendations on page 72 of this manual.

- **Maintenance**

Timing belts are maintenance-free, when used under normal operating conditions.

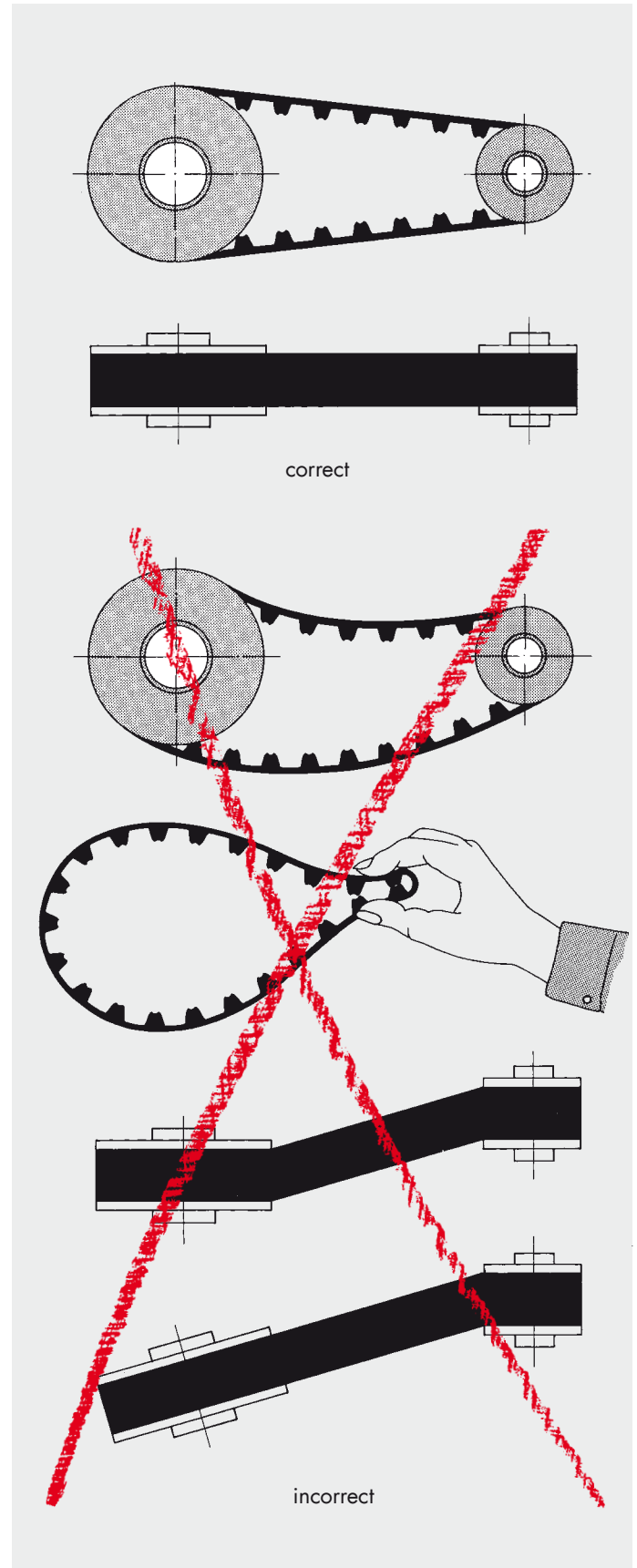

Design Hints

Problems – Causes – Remedies



Power Transmission

Problems	Causes	Remedies
Excessive wear on the loaded face of the belt tooth	Faulty belt tension Pitch error Overload	Correct the tension Check the belt section, replace, if necessary Use wider belts with higher power transmission capacity
Excessive wear on the land between the belt teeth	Excessive belt tension Drive is under designed Defective timing pulleys	Reduce the tension Increase the width of the timing belt or increase the diameter of the timing pulleys Replace timing pulleys
Exceptional wear on the belt sides	Faulty axial parallelism Defective flanged pulleys Centre distance fluctuation	Realign shafts Replace flanged pulleys Reinforce bearings and/or housing
Belt teeth shear off	Number of teeth in mesh too small Overload	Increase diameter of the small pulley or choose a wider belt Use wider belts or larger pulleys
Excessive lateral runout	Faulty axial parallelism Timing pulleys not aligned Shock loading with excessive belt tension	Realign shafts Realign the pulleys Reduce the belt tension
Pulley flanges becoming detached	Timing pulleys not aligned Very high lateral pressure from the timing belt Faulty installation of the flanged pulleys	Realign the pulleys Realign shafts Install flanged pulleys correctly
Apparent belt stretch	Recovery of length after storage Bearings flexing	Correct the belt tension, reinforce and secure bearing mountings
Excessive running noise	Faulty shaft alignment Excessive belt tension Pulley diameter too small Overload on the timing belt Excessive belt width coupled with high speed	Realign shafts Reduce the tension Enlarge pulley diameter Increase belt width and/or teeth in mesh Reduce belt width by redesigning using heavier belt section
Abnormal wear and tear on the timing pulleys	Unsuitable pulley material Faulty meshing Insufficient surface hardness	Use a stronger material Replace timing pulleys Use harder material or harden the surface
Embrittlement of the belt top surface	Ambient temperatures above +100 °C Excessive radiation	Choose an extra heat resistant belt quality Shield or use a suitable belt quality
Cracks in the belt top surface	Ambient temperatures below –30 °C	Use an extra cold resistant belt quality
Softening of the belt top surface	Contamination by incompatible media	Shield belt or use suitable belt quality

Design Hints

Data Sheet for the Calculation/Checking of Drives with Timing Belts for **optibelt OMEGA** Sections



Company: _____
 Street address/P.O. Box number: _____
 Town or city/Post code: _____
 Contact person: _____
 Department: _____ Date: _____
 Phone: _____ Fax: _____
 E-mail: _____

For test New drive
 For pilot production Existing drive
 For series production Requirement _____ Pieces/Year

Currently fitted with

Pitch length	Section	Width	Manufacturer

Prime mover

Type (e.g. electric motor, diesel engine 3 cylinders) _____
 Size of the starting torque (e.g. MA = 1.8 MN) _____
 Type of start (e.g. star delta) _____
 Daily operating time _____ hours
 Number of starts _____ per hour per day
 Change in the direction of rotation per minute per hour
 Power: P normal _____ kW
 P maximum _____ kW
 or max. torque _____ Nm at n_1 _____ min^{-1}
 Speed n_1 _____ min^{-1}
 Shaft layout: Horizontal Vertical
 Inclined α _____ °
 Maximum permissible shaft loading $S_{a \max}$ _____ N
 Pitch diameter or number of teeth on the pulley:
 d_{w1} _____ mm z_1 _____ mm
 $d_{w1 \min}$ _____ mm $z_{1 \min}$ _____ mm
 $d_{w1 \max}$ _____ mm $z_{1 \max}$ _____ mm
 Maximum pulley face width _____ mm

Driven machine

Type (e.g. lathe, compressor) _____
 Start: under load no load
 Type of load: steady pulsating
 shock
 Required power transmission: P normal _____ kW
 P maximum _____ kW
 or max. torque _____ Nm at n_2 _____ min^{-1}
 Driven speed n_2 _____ min^{-1}
 $n_{2 \min}$ _____ min^{-1}
 $n_{2 \max}$ _____ min^{-1}
 Maximum permissible shaft loading $S_{a \max}$ _____ N
 Pitch diameter or number of teeth on the pulley:
 d_{w2} _____ mm z_2 _____ mm
 $d_{w2 \min}$ _____ mm $z_{2 \min}$ _____ mm
 $d_{w2 \max}$ _____ mm $z_{2 \max}$ _____ mm
 Maximum pulley face width _____ mm

Drive ratio i _____
 i_{\min} _____ i_{\max} _____
 Centre distance a _____ mm
 a_{\min} _____ mm a_{\max} _____ mm
 Tensioning/idler pulley: inside idler
 outside idler
 d_w _____ mm pulley
 d_a _____ mm flat pulley
Operating conditions: Ambient temperature _____ °C minimum
 _____ °C maximum
 (e.g. oil mist, drops) _____
 (e.g. spray water) _____
 (type, concentration, temperature) _____
 (type) _____
 Influence of oil
 water
 acid
 dust

Special drives: e.g. for drives with tensioning/idler pulleys, three or multi-pulley drives or for drives with contra rotating pulleys drawings are necessary. Please use the other side of this page for this drawing.



Power Transmission

Details of the drive:



Power Transmission

All rights reserved. Any infringements of the copyright are liable to criminal prosecution. Errors and omissions excepted.

The Optibelt offer is intended for specialised distributors only. Optibelt recommends that its products be used only in accordance with the information in the Optibelt technical manuals. Due to safety recommendations, the application of Optibelt drive belts in aircrafts or in systems similar to aircrafts is not permissible. Optibelt will not be held responsible if the products are used in applications for which they have not been developed or designed. Optibelt would also mention its general terms and conditions.

The valid terms and conditions are available at www.optibelt.com

© Arntz Optibelt Group 315062/0110Hux

optibelt



Lieferprogramm Product Range



1 **optibelt RED POWER II**
5 **optibelt KB RED POWER II**
Hochleistungs-Schmalkeilriemen,
wartungsfrei
*High performance wedge belts,
maintenance-free*

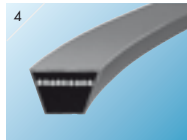
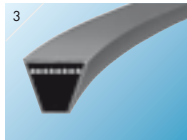
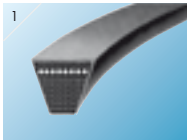

2 **optibelt BLUE POWER**
6 **optibelt KB BLUE POWER**
Hochleistungs-Schmalkeilriemen
High performance wedge belts

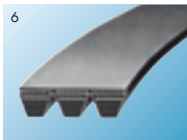
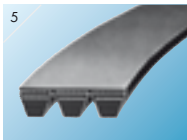

3 **optibelt SK**
7 **optibelt KB SK**
Schmalkeilriemen
Wedge belts

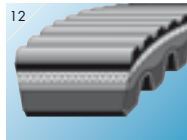
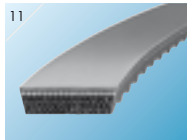
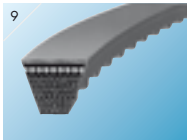

4 **optibelt VB**
8 **optibelt KB VB**
Klassische Keilriemen
Classical V-belts

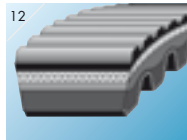
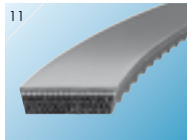
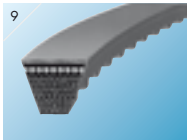

9 **optibelt Super X-POWER M-S**
Keilriemen, flankenoffen,
formgezahnt
*V-belts, raw edge,
moulded cogged*

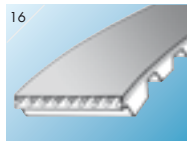
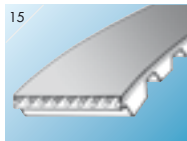

10 **optibelt Super KBX-POWER**
Kraftbänder, flankenoffen
Kraftbands, raw edge

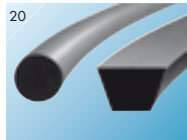
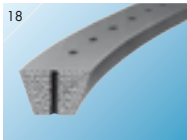
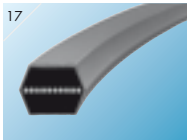

11 **optibelt SUPER VX**
Breitkeilriemen, flankenoffen,
formgezahnt
*Variable speed belts,
raw edge, moulded cogged*



12 **optibelt SUPER DVX**
Doppel-Breitkeilriemen,
flankenoffen, formgezahnt
*Double section variable speed belts,
raw edge, moulded cogged*



13 **optibelt ZR**
optibelt ZR linear
Zahnriemen aus Chloropren
Chloroprene timing belts



14 **optibelt OMEGA HL**
optibelt OMEGA HP
optibelt OMEGA FanPower
optibelt OMEGA linear
Zahnriemen aus Chloropren
Chloroprene timing belts

15 **optibelt ALPHA Power**
16 **optibelt ALPHA**
optibelt ALPHA linear / V
optibelt ALPHAflex
Zahnriemen aus Polyurethan
Polyurethane timing belts

17 **optibelt DK**
Doppelkeilriemen
Double section V-belts

18 **optimat OE**
Endliche Keilriemen
DIN 2216, gelocht
*Open-ended V-belt,
punched*

19 **optibelt RB**
Rippenbänder
Ribbed belts

20 **optibelt RR / RR PLUS**
Kunststoffrundriemen
Plastic round section belting

20 **optibelt KK**
Kunststoffkeilriemen
Plastic V-belt

21 **optibelt KS**
Keilrillenscheiben
V-grooved pulleys

22 **optibelt ZRS**
Zahnriemenscheiben
Timing belt pulleys

23 **optibelt RBS**
Rippenbandscheiben
Ribbed belt pulleys

24 **optibelt SERVICE KIT**