

【Hardware】

Contents

Chapter 1 : Introduction of FATEK FBS Series PLC

1.1 Appearance of Main Unit	H1-1
1.2 Appearance of Expander/Module	H1-2
1.3 Appearance of Communication Expansion Module	H1-4
1.4 List of FBS-PLC Models	H1-5
1.5 Specifications of Main Unit.....	H1-7
1.6 Environmental Specifications	H1-8
1.7 Connection Diagrams of Various Models	H1-9
1.7.1 NC Control Main Unit.....	H1-9
1.7.2 Basic/Advanced Main Unit.....	H1-10
1.7.3 Digital I/O Expander.....	H1-12
1.7.4 Digital I/O Expansion Module.....	H1-13
1.7.5 High-Density Digital I/O Expansion Module	H1-14
1.7.6 Numeric I/O Expansion Module	H1-14
1.7.7 Analog I/O Expansion Module.....	H1-14
1.7.8 Temperature Input Module	H1-15
1.7.9 Expansion Power.....	H1-15
1.7.10 Communication Module (CM)	H1-16
1.7.11 Communication Board (CB)	H1-17
1.8 Drawings with External Dimensions	H1-18

Chapter 2 : System Architecture

2.1 Single-Unit System of FBS-PLC.....	H2-1
2.2 Formation of Multiple Units	H2-2
2.2.1 Connection of multiple FBS-PLC	H2-2
2.2.2 Connection of FBS-PLC with host computer or intelligent peripherals	H2-3

Chapter 3 : Expansion of FBS-PLC

3.1 I/O Expansion	H3-1
-------------------------	------

3.1.1	Digital I/O Expansion and I/O Numbering.....	H3-1
3.1.2	Numeric I/O Expansion and I/O Channel Mapping	H3-3
3.2	Expansion of Communication Port.....	H3-4

Chapter 4 : Installation Guide

4.1	Installation Environment.....	H4-1
4.2	PLC Installation Precautions	H4-1
4.2.1	Placement of PLC.....	H4-1
4.2.2	Ventilation Space	H4-2
4.3	Fixation by DIN RAIL.....	H4-3
4.4	Fixation by Screws	H4-4
4.5	Precautions on Construction and Wiring.....	H4-6

Chapter 5 : Wiring of Power Supply, Power Consumption Calculation, and Power Sequence Requirement

5.1	Specifications and Wiring of AC Power Sourced Power Supply	H5-1
5.2	Specifications and Wiring of DC Power Sourced Power Supply	H5-2
5.3	Residual Capacity of Main/Expansion Units and Current Consumption of Expansion Module	H5-4
5.3.1	Residual Capacity of Main Unit/Expansion Unit.....	H5-4
5.3.2	Maximum Current Consumption of Expansion Module	H5-5
5.4	Requirement on Power Sequence of Main Unit and Expansion Unit/Module	H5-6

Chapter 6 : Digital Input (DI) Circuits

6.1	Specifications of Digital Input (DI) Circuits.....	H6-1
6.2	Structure and Wiring of 5VDC Ultra High Speed Differential Input Circuit	H6-2
6.3	24VDC Single-End Input Circuit and Wiring for SINK/SRCE Input	H6-3

Chapter 7 : Digital Output (DO) Circuits

7.1	Specifications of Digital Output Circuits	H7-1
7.2	5VDC Ultra High Speed Line-Driver Differential Output Circuit and its Wiring	H7-3
7.3	Single-End Output Circuit	H7-3
7.3.1	Structure and Wiring of Single-End Relay Output Circuit.....	H7-3
7.3.2	Structure and Wiring of Single-End Transistor SINK & SRCE Output Circuit.....	H7-4

7.3.3	Structure and Wiring of Single-End TRIAC Output Circuit.....	H7-5
7.4	Speed up the Single-End Transistor Output Circuit (only applicable to high and intermediate-speed)	H7-6
7.5	Output Device Protection and Noise Suppression.....	H7-6
7.5.1	Protection of Relay Contact and Noise Suppression	H7-6
7.5.2	Protection of Transistor and Noise Suppression.....	H7-8

Chapter 8 : Test Run, Monitoring and Maintenance

8.1	Inspection after Wiring and before First Time Power on.....	H8-1
8.2	Test Run and Monitoring	H8-1
8.3	LED Indications of Main Units and Troubleshooting	H8-2
8.4	Maintenance	H8-4
8.5	The charge of battery & recycle of used battery	H8-4

【 Hardware 】

Chapter 1 Introduction of FATEK FBS Series PLC

The FATEK FBS Series PLC is a new generation of micro PLC equipped with excellent functions comparable to medium or large PLC, with up to five communication ports. The maximum I/O numbers are 256 points for Digital Input (DI) and Digital Output (DO), 64 words for Numeric Input (NI) and Numeric Output (NO). The Main Units of FBS are available in three types: MA (Economy Type), MC (High-Performance Type), and MN (High-Speed NC Type). With the combination of I/O point ranges from 10 to 60, a total of 17 models are available. Fourteen DI/DO and 12 NI/NO models are available for Expansion Units/Modules. With interface options in RS232, RS485, USB and Ethernet, the communication peripherals are available with 14 boards and modules. The various models are described in the following:

1.1 Appearance of Main Unit

All the Main Units of FBS-PLC have the same physical structure. The only difference is the case width. There are four different case sizes, which are 60mm, 90mm, 130mm, and 175mm. The figure below will use the Main Unit case of the FBS-24MC as an example for illustration:

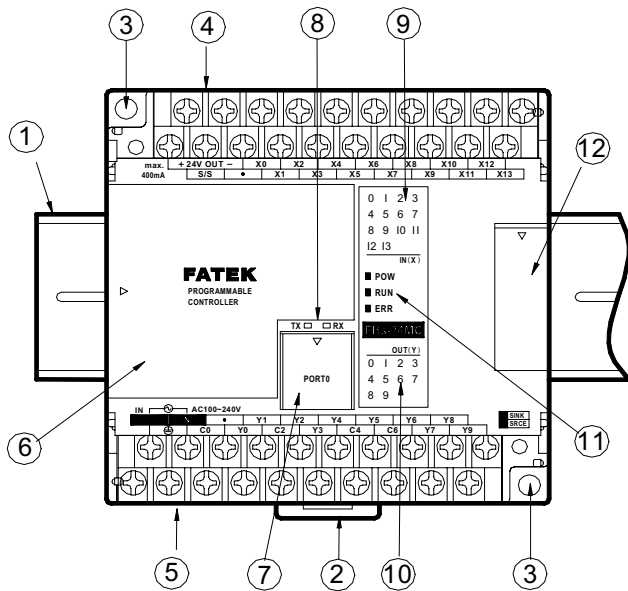

(Front view without Communication Board)

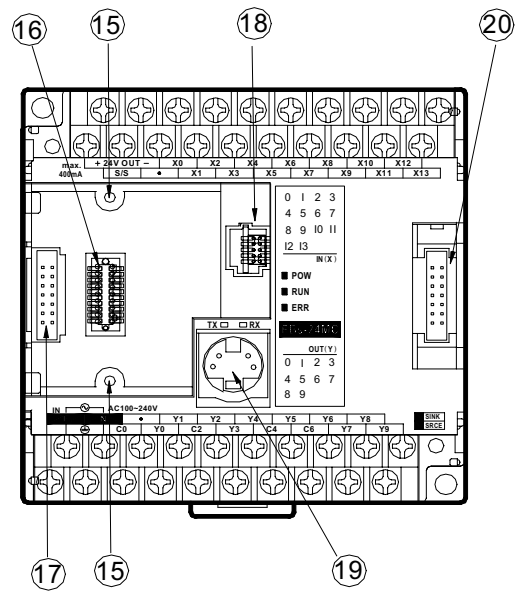

(Front view with cover plate removed)

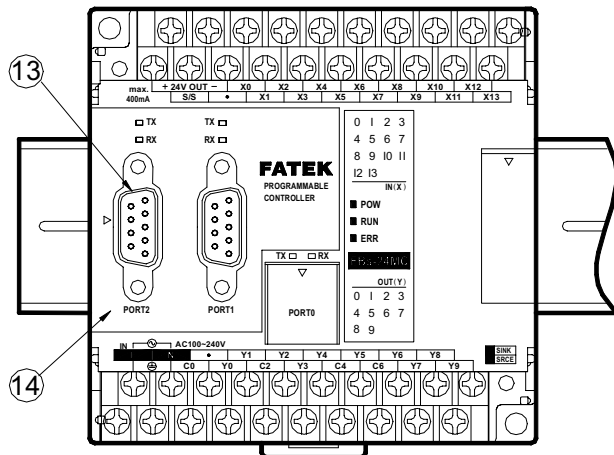

(Front view with CB-22 Board installed)

- ① 35mm-width DIN RAIL
- ② DIN RAIL tab
- ③ Hole for screw fixation ($\phi 4.5 \times 2$)
- ④ Terminals of 24VDC power input and digital input (Pitch 7.62mm)
- ⑤ Terminals of main power input and digital output (Pitch 7.62mm)
- ⑥ Standard cover plate (without communication board)
- ⑦ Cover plate of built-in communication port (Port 0)

- ⑧ Indicators for transmit (TX) and receive (RX) status of built-in communication port (Port0).
- ⑨ Indicator for Digital Input (Xn).
- ⑩ Indicator for Digital Output (Yn).
- ⑪ Indicator for system status (POW, RUN, ERR).
- ⑫ I/O output expansion header cover [units of 20 points or beyond only], with esthetic purpose and capable of securing expansion cable.
- ⑬ FBs-CB22 Communication Board (CB).
- ⑭ FBs-CB22 CB cover plate (each CB has its own specific cover plate)
- ⑮ Screw holes of communication board.
- ⑯ Connector for communication board (for CB2, CB22, CB5, CB55, and CB25)
- ⑰ Connector for Communication Module (CM) (only available in MC/MN model, for CM22, CM25, CM55, CM25E, and CM55E connection).
- ⑱ Connector for Memory Pack.
- ⑲ Connector for built-in communication port (Port 0) (With USB and RS232 optional, shown in the figure is for RS232)
- ⑳ I/O output expansion header (only available in units with 20 points or beyond), for connecting with cables from expansion units/modules.

1.2 Appearance of Expansion Unit/Module

There are three types of cases for expansion units/modules. One type uses the same case as main unit that of the 90mm, 130mm, and 175mm, while the other two have thinner 40mm and 60mm cases, which are for expansion modules. All expansion cables (left) of expansion units/modules are flat ribbon cables (6cm long), which were soldered directly on the PCB, and the expansion header (right) is a 14Pin Header, with this to connect the right adjacent expansion units/modules. In the following, each of the three types of expansion units/modules is described as an example:

- Expansion unit/module with 90mm, 130mm, or 175mm width case: [-24EA(P), -40EA(P), -60EA(P), -TC16, -RTD16]

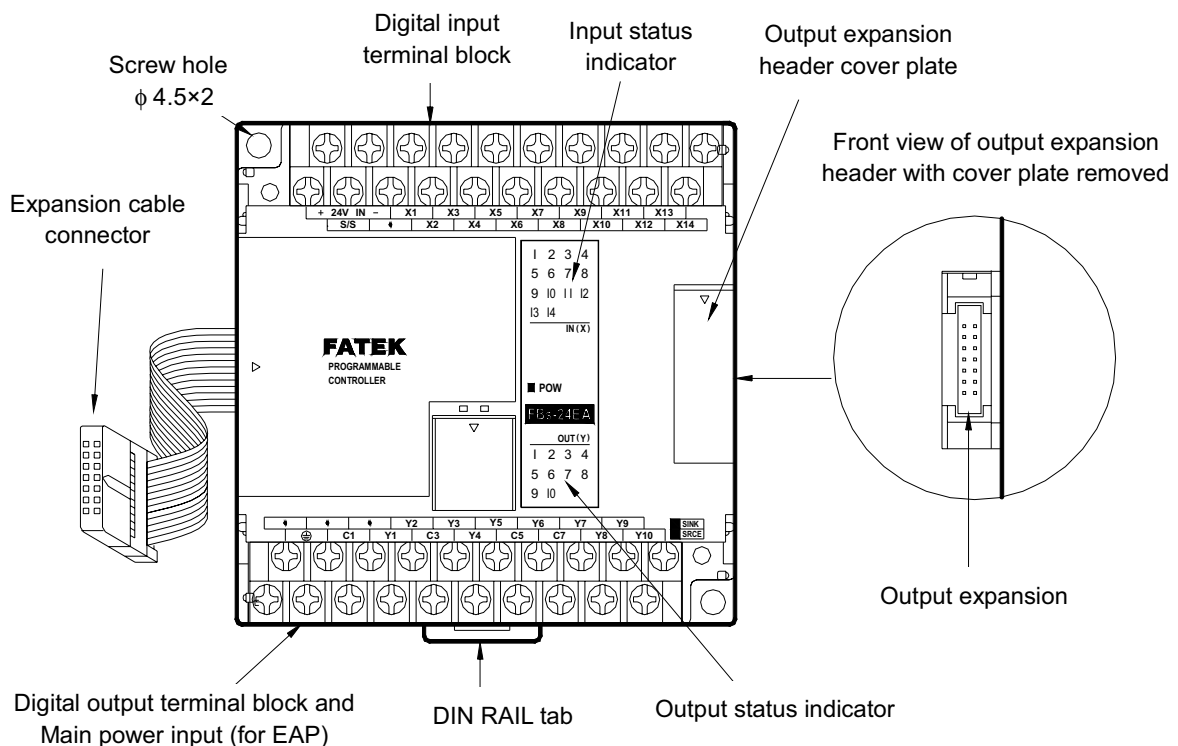

- Expansion unit/module with 60mm width case: (-16EA, -16EY, -20EX)

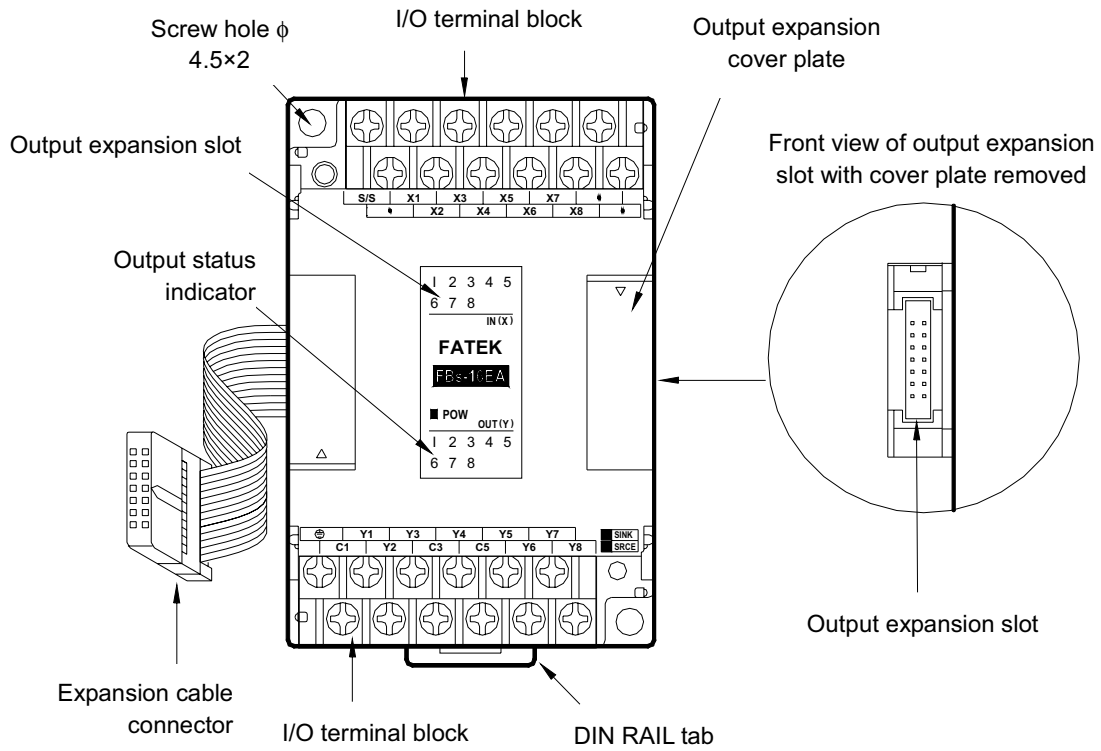

- Expansion module with 40mm width case: (-8EA, -8EY, -8EX, -6AD, -2DA, -4DA, -4A2D, -7SG Δ , -TC2, -TC6, -RTD6, -CM5H)

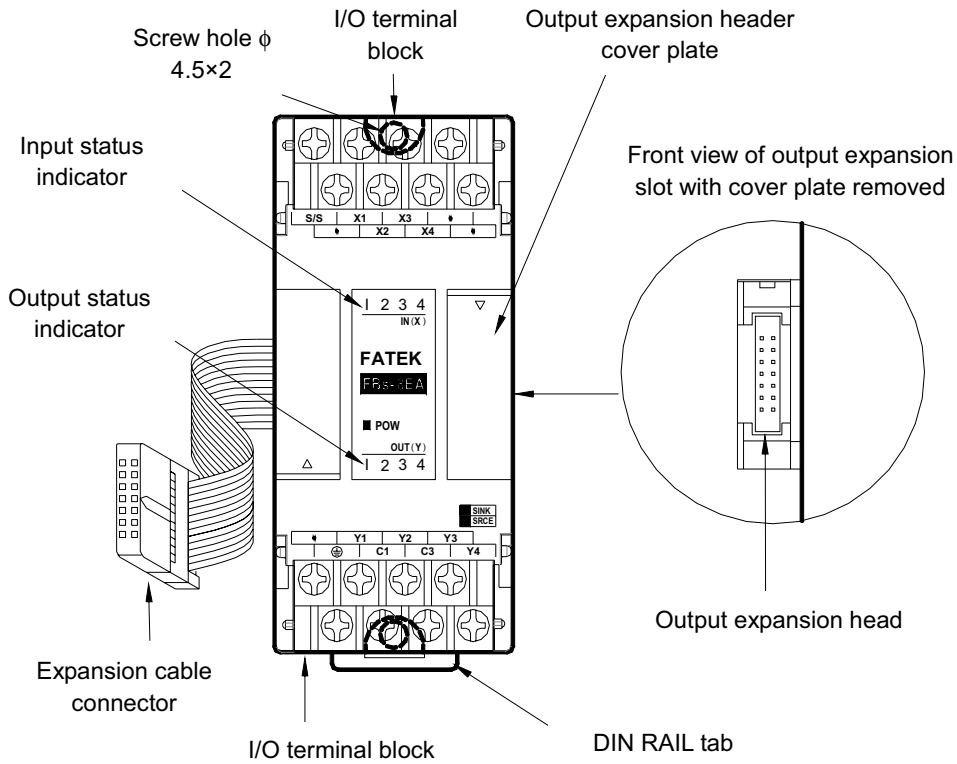

- Expansion module with 40mm width case: (-24EX, -24EYT, -32DGI)

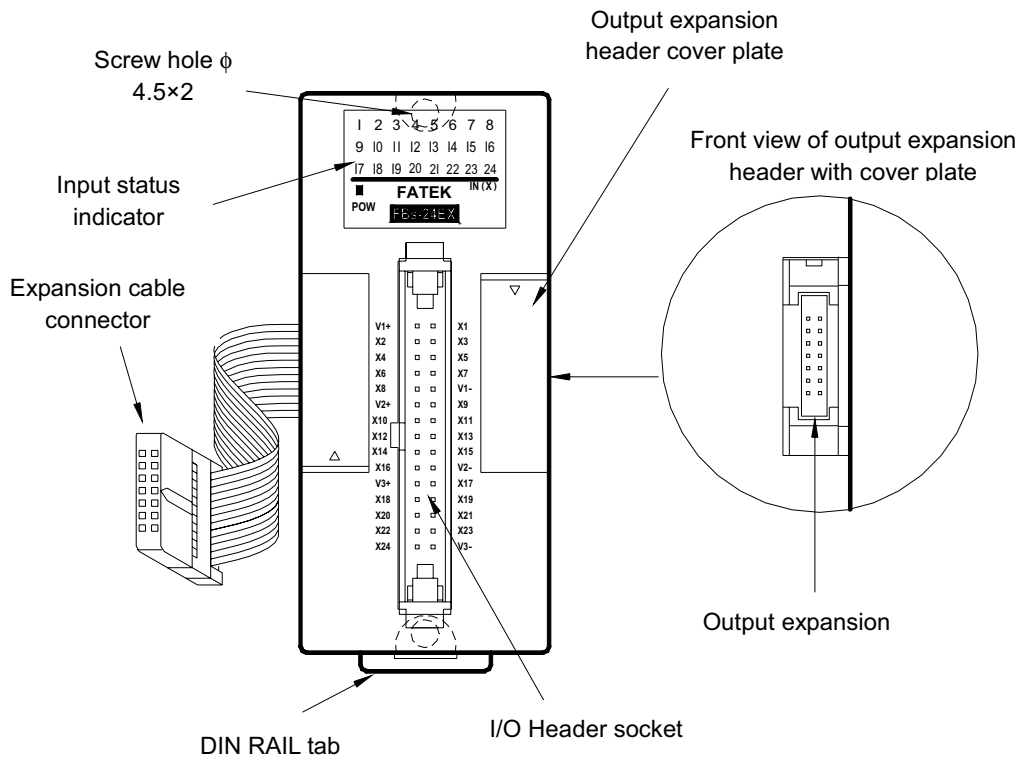

1.3 Appearance of Communication Expansion Module

The Communication Module (CM) of FBs-PLC has a 25mm-width case, which can be used in the following seven modules: -CM22, -CM25, -CM55, -CM25E, -CM55E, -CM25C, -CM5R.

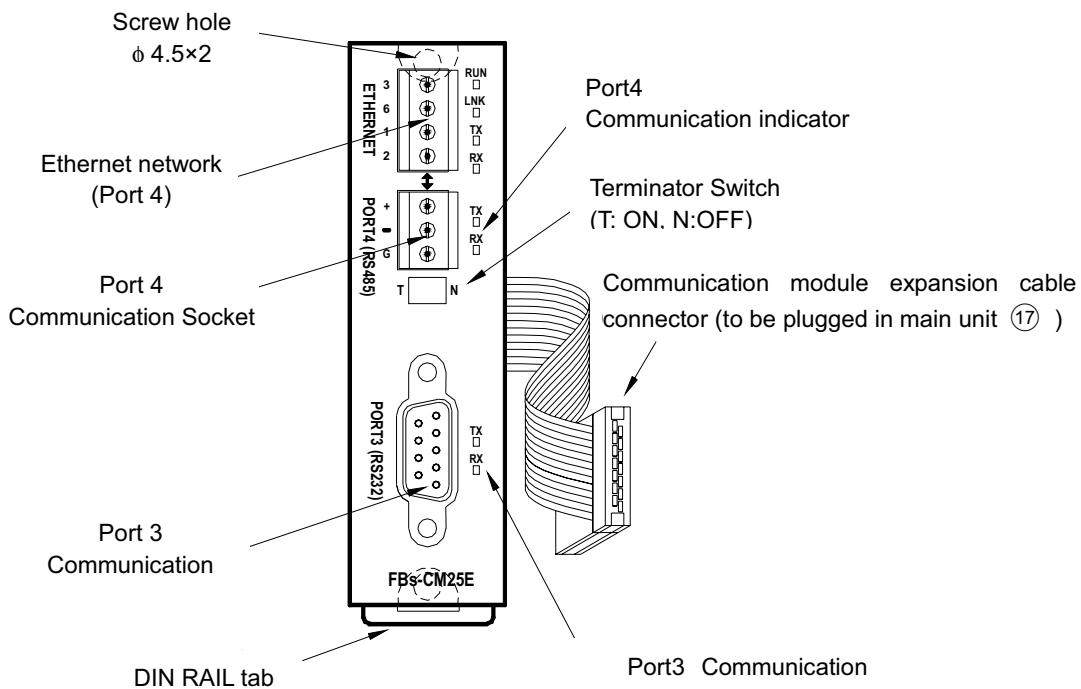

1.4 List of FBS PLC Models

Item Name	Model Number	Specifications	
NC Control Main Unit	FBS-20MN□◇△ - ◎	2 points 7920KHz 5VDC differential input, 10 points 24VDC digital input (20KHz), 2 points 7920KHz 5VDC differential output, 6 points (R/T/S) digital output (Model "T" 6 points 20KHz output), 1 RS232 or USB port (expandable up to 5), built-in RTC, detachable terminal block	
	FBS-32MN□◇△ - ◎	4 points 920KHz 5VDC digital differential input, 16 Points 24VDC digital input (20KHz for 12 Points), 4 points 7920KHz 5VDC digital differential output, 8 Points (R/T/S) digital output (Model "T" 4 Points 20KHz output), 1 RS232 or USB port (expandable up to 5), built-in RTC, detachable terminal block	
	FBS-44MN□◇△ - ◎	8 points 7920KHz 5VDC digital differential input, 20 Points 24VDC digital input (20KHz for 8 points), 8 points 7920KHz 5VDC digital differential output, 8 points (R/T/S) digital output (Model "T" 4 Points 20KHz output), 1 RS232 or USB port (expandable up to 5), built-in RTC, detachable terminal block	
Advanced Main Unit	FBS-10MC□◇△ - ◎ - XY	6 points 24VDC digital input (2 points 100KHz+4 points 20KHz), 4 points (R/T/S) digital output (Model "T" 2 points 100KHz+2 points 20KHz output), 1 RS232 or USB port (expandable up to 5), built-in RTC, I/O is not expandable	
	FBS-14MC□◇△ - ◎ - XY	8 points 24VDC digital input (2 points 100KHz+6 points 20KHz), 6 points (R/T/S) digital output (Model "T" 2 points 100KHz+4 points 20KHz output), 1 RS232 or USB port (expandable up to 5), built-in RTC, I/O is not expandable	
	FBS-20MC□◇△ - ◎ - XY	12 points 24VDC digital input (2 points 100KHz+10 points 20KHz), 8 points (R/T/S) digital output (Model "T" 2 points 100KHz+6 points 20KHz output), 1 RS232 or USB port (expandable up to 5), built-in RTC	
	FBS-24MC□◇△ - ◎ - XY	14 points 24VDC digital input (2 points 100KHz+12 points 20KHz), 10 points (R/T/S) digital output (Model "T" 2 points 100KHz+6 points 20KHz output), 1 RS232 or USB port (expandable up to 5), built-in RTC, detachable terminal block	
	FBS-32MC□◇△ - ◎ - XY	20 points 24VDC digital input (2 points 100KHz+14 points 20KHz), 12 Points (R/T/S) digital output (Model "T" 2 points 100KHz+6 points 20KHz output), 1 RS232 or USB port (expandable up to 5), built-in RTC, detachable terminal block	
	FBS-40MC□◇△ - ◎ - XY	24 points 24VDC digital input (2 points 100KHz+14 points 20KHz), 16 points (R/T/S) digital output (Model "T" 2 points 100KHz+6 points 20KHz output), 1 RS232 or USB port (expandable up to 5), built-in RTC, detachable terminal block	
	FBS-60MC□◇△ - ◎ - XY	36 points 24VDC digital input (2 points 100KHz+14 points 20KHz), 24 points (R/T/S) digital output (Model "T" 2 points 100KHz+6 points 20KHz output), 1 RS232 or USB port (expandable up to 5), built-in RTC, detachable terminal block	
Basic Main Unit	FBS-10MA□◇△ - ◎	6 points 24VDC digital input (up to 10KHz in 4 points), 4 Points (R/T/S) digital output (Model "T" has 4 points 10KHz output), one RS232 or USB port (can be expanded up to 3), I/O is not expandable	
	FBS-14MA□◇△ - ◎	8 points 24VDC digital input (up to 10KHz in 4 points), 6 points (R/T/S) digital output (Model "T" has 4 points 10KHz output), one RS232 or USB port (can be expanded up to 3), I/O is not expandable	
	FBS-20MA□◇△ - ◎	12 points 24VDC digital input (up to 10KHz in 4 points), 8 points (R/T/S) digital output (Model "T" has 4 points 10KHz output), one RS232 or USB port (can be expanded up to 3)	
	FBS-24MA□◇△ - ◎	14 points 24VDC digital input (up to 10KHz in 4 points), 10 points (R/T/S) digital output (Model "T" has 4 points 10KHz output), one RS232 or USB port (can be expanded up to 3)	
	FBS-32MA□◇△ - ◎	20 points 24VDC digital input (up to 10KHz in 4 points), 12 points (R/T/S) digital output (Model "T" has 4 points 10KHz output), one RS232 or USB port (can be expanded up to 3)	
	FBS-40MA□◇△ - ◎	24 points 24VDC digital input (up to 10KHz in 4 points), 16 points (R/T/S) digital output (Model "T" has 4 points 10KHz output), one RS232 or USB port (can be expanded up to 3)	
	FBS-60MA□◇△ - ◎	36 points 24VDC digital input (up to 10KHz in 4 points), 24 points (R/T/S) digital output (Model "T" has 4 points 10KHz output), one RS232 or USB port (can be expanded up to 3)	
Expansion Power	FBS-EPOW-◎	Power supply for expansion module, with single 5VDC and dual 24VDC voltage output and up to 20VA capacity	
Digital Expansion Unit	FBS-24EAP□◇ - ◎	14 points 24VDC digital input, 10 points (R/T/S) digital output, built-in power supply	
	FBS-40EAP□◇ - ◎	24 points 24VDC digital input, 16 points (R/T/S) digital output, built-in power supply	
	FBS-60EAP□◇ - ◎	36 points 24VDC digital input, 24 points (R/T/S) digital output, built-in power supply	
Digital I/O Module	Digital Expansion Unit	FBS-8EA□◇	4 points 24VDC digital input, 4 points (R/T/S) digital output
		FBS-8EX	8 points 24VDC digital input
		FBS-8EY□◇	8 points (R/T/S) digital output
		FBS-16EA□◇	8 points 24VDC digital input, 8 points (R/T/S) digital output
		FBS-16EY□◇	16 points (R/T/S) digital output
		FBS-20EX	20 points 24VDC digital input
		FBS-24EA□◇	14 points 24VDC digital input, 10 points (R/T/S) digital input
		FBS-40EA□◇	24 points 24VDC digital input, 16 points (R/T/S) digital output
		FBS-60EA□◇	36 points 24VDC digital input, 24 points (R/T/S) digital output
	High-Density Digital Expansion Module	FBS-24EX	24 points high-density 24VDC digital input, 30-Pin Header with latch
FBS-24EYT		24 points high-density transistor Sink type digital output (0.1A max.), 30-Pin Header with latch	

Item Name		Model Number	Specifications
Numeric I/O Module	Numeric I/O Expansion Module	FBs-7SG1	1 set (8 digits) 7 segment LED display (or 64 Points independent LED) output display module, 16-Pin Header connector
		FBs-7SG2	2 set (16 digits) 7 segment LED display (or 128 Points independent LED) output display module, 16-Pin Header connector
		FBs-32DGI	8 set 4 digits (total 32 digits) Thumbwheel switch (or 128 Points independent switch) multiplex input module, 30-Pin Header connector
	Analog Expansion Module	FBs-6AD	6 channel, 14 bits analog input module (-10V~0V~+10V or -20mA~0mA~+20mA)
		FBs-2DA	2 channel, 14 bits digital output module (-10V~0V~+10V or -20mA~0mA~+20mA)
		FBs-4DA	4 channel, 14 bits digital output module (-10V~0V~+10V or -20mA~0mA~+20mA)
		FBs-4A2D	4 channel, 14 bits analog input + 2 channel, 14 bits digital output combo analog module (-10V~0V~+10V or -20mA~0mA~+20mA)
	Temperature Input Module	FBs-TC2	2 channel thermocouple temperature input module with 0.1°C resolution
		FBs-TC6	6 channel thermocouple temperature input module with 0.1°C resolution
		FBs-RTD6	6 channel RTD temperature input module with 0.1°C resolution
FBs-TC16		16 channel thermocouple temperature input module with 0.1°C resolution	
Communication Expansion Module	FBs-CM22	2 port RS232 (Port3+Port4) communication module	
	FBs-CM55	2 port RS485 (Port3+Port4) communication module	
	FBs-CM25	1 port RS232 (Port3)+1 port RS485 (Port4) communication module	
	FBs-CM25E	1 port RS232 (Port3)+1 port RS485 (Port4)+Ethernet network interface communication module	
	FBs-CM55E	1 port RS485 (Port3)+1 port RS485 (Port4)+Ethernet network interface communication interface	
	FBs-CM25C	General purpose RS232 ↔ RS485 Converter with optical isolation	
	FBs-CM5R	General purpose RS485 Repeater with optical isolation	
	FBs-CM5H	General purpose 4-port RS485 HUB with optical isolation	
Communication Expansion Board	FBs-CB2	1 port RS232 (Port2) communication board	
	FBs-CB22	2 port RS232 (Port1+Port2) communication board	
	FBs-CB5	1 port RS485 (Port2) communication board	
	FBs-CB55	2 port RS485 (Port1+Port2) communication board	
	FBs-CB25	1 port RS232 (Port1)+1 port RS485 (Port2) communication board	
	FBs-CBE	1 port Ethernet communication board	
Communication Cable	FBs-232P0-9F-150	FBs-Main unit Port0 RS232 to 9Pin female D-Sub communication cable, 150cm long	
	FBs-232P0-9M-400	FBs-Main unit Port0 RS232 to 9Pin male D-Sub communication cable, 400cm long	
	FBs-USBP0-180	FBs-Main unit Port0 USB communication cable (standard USB A ↔ B)	
Memory Pack	FBs-PACK	FBs-PLC Program memory pack with 20Kword program, 20Kword register, and write protection switch	
	FP-07C	Hand held programmer for FBs-PLC	
Programming Device	WinProladder	WinProladder Programming software for Windows	
	FATEK Comm. Server	FATEK DDE communication server	
Others	FBs-XTNR	Extension cable adapter	
	HD30-22AWG-200	Include 22AWG I/O cable for 30Pin Header connector, 200cm long (for FBs-24EX, -24EYT, and -32DGI)	
	DBAN.8(DBAN.8LEDR)	0.8 " × 4 16 segment display board (with red LED installed)	
16/7 Segment LED Display Board	DBAN2.3(DBAN2.3LEDR)	2.3 " × 4 16 segment display board (with red LED installed)	
	DB.56 (DB.56LEDR)	0.56 " × 8 7 segment display board (with red LED installed)	
	DB.8 (DB.8LEDR)	0.8 " × 8 7 segment display board (with red LED installed)	
	DB2.3 (DB2.3LEDR)	2.3 " × 8 7 segment display board (with red LED installed)	
	DB4.0 (DB4.0LEDR)	4.0 " × 4 7 segment display board (with red LED installed)	
Simple People Human Machine Interface	FB-DAP-B(R)	16×2 LCD character display, 20key keyboard, 24VDC power supply, RS-485 communication interface (suffix R means wireless read card module included)	
	FB-DAP-C(R)	16×2 LCD character display, 20key keyboard, 5VDC power supply, RS232 communication interface (suffix R means wireless read card module included)	
RFID Card	CARD-1	Read-only wireless card (for FB-DAP-BR/CR)	
	CARD-2	Read/Write wireless card(for FB-DAP-BR/CR)	
Education and Training Kit	FBs-TBOX	46cm × 32cm × 16cm suitcase, containing FBs-24MCT main unit, FBs-CM25E communication module (RS232 + RS485 + Ethernet network), 14 simulated input switches, 10 external relay isolation output, Doctor terminal outlet I/O, peripherals such as stepping motor, encoder, 7 segment display, 10 of 10 φ LED indicator, thumbwheel switch, and 16key keyboard.	

- : Blank – relay output , T – transistor output , S – TRIAC output
- ◇ : Blank – Sink (NPN) , J – Source (PNP)
- △ : Blank – built-in RS232 port , U – built-in USB port
- ⊙ : Blank – 100~240VAC power supply , D – 24VDC power supply
- Specifications are subject to changes without further notice.

- XY : (optional),The expanding 120KHz inputs(X) and output(Y), there are 1~6 Points can be expanded for both X,Y.
Example:FBs-24MCT-21,Its means expanding 2 points of 120KHz input(total 4 points) and 1 point of 120 KHz output(total 3 points).
And FBs-24MCT-02 means only expanding 2 points of 120KHz output(total 4 points).

1.5 Specifications of Main Unit

*** Default Settings

Item		Specification				Note		
Execution Speed		0.33uS / per Sequence Command						
Space of Control Program		20K Words						
Program Memory		FLASH ROM or SRAM + Lithium battery for Back-up						
Sequence Command		36						
Application Command		300 (113 types)				Include Derived Commands		
Flow Chart (SFC) Command		4						
Single Point 《BIT Status》	X	Output Contact(DI)		X0~X255 (256)		Corresponding to External Digital Input Point		
	Y	Output Relay(DO)		Y0~Y255 (256)		Corresponding to External Digital Output Point		
	TR	Temporary Relay		TR0~TR39 (40)				
	M	Internal Relay	Non-retentive		M0~M799 (800)*		Can be configured as retentive type	
			Retentive		M1400~M1911 (512)			
		Special Relay		M800~M1399 (600)*		Can be configured as non-retentive type		
	S	Step Relay	Non-retentive		S0~S499 (500)*		S20~S499 can be configured as retentive type	
			Retentive		S500~S999 (500)*		Can be configured as non-retentive type	
	T	Timer "Time Up" Status Contact		T0~T255 (256)				
	C	Counter "Count Up" Status Contact		C0~C255 (256)				
Register 《WORD Data》	TMR	Current Time Value Register	0.01S Time base		T0~T49 (50)*		T0 ~ T255 Numbers for each time base can be flexibly adjusted.	
			0.1S Time base		T50~T199 (150)*			
			1S Time base		T200~T255 (56)*			
	CTR	Current Counter Value Register	16-Bit	Retentive		C0~C139 (140)*		Can be configured as non-retentive type
				Non-retentive		C140~C199 (60)*		Can be configured as retentive type
		32-Bit	Retentive		C200~C239 (40)*		Can be configured as non-retentive type	
			Non-retentive		C240~C255 (16)*		Can be configured as retentive type	
	HR DR	Data Register		Retentive		R0~R2999 (3000)* D0~D3999 (4000)		Can be configured as non-retentive type
				Non-retentive		R3000~R3839 (840)*		Can be configured as retentive type
	HR ROR	Data Register		Retentive		R5000~R8071 (3072)*		When not configured as ROR, it can serve as normal register (for read/Write)
				Read-only Register		R5000~R8071 can be configured as ROR, default setting is (0)*		ROR is stored in special ROR area and not consume program space
				File Register		F0~F8191 (8192)*		Must save/retrieved via special commands
	IR	Input register		R3840~R3903 (64)		Corresponding to external numeric input		
	OR	Output Register		R3904~R3967 (64)		Corresponding to external numeric output		
	SR	Special System Register		R3968~R4167 (197) R4000~R4095 (96)		Except R4152~4154		
	《Special Register》	0.1mSHigh Speed Timer register		R4152~R4154 (3)				Not available in MA model
		High Speed Counter Register	Hardware(4 sets)		DR4096~DR4110 (4×4)			
			Software (4 sets)		DR4112~DR4126 (4×4)			
		Real Time Calendar Register		R4128 (sec)	R4128 (min)	R4130 (hour)	R4131 (day)	
			R4132 (month)	R4133 (year)	R4134 (week)			
XR	Index Register		V - Z (2), P0~P9 (10)					
Interrupt Control	External Interrupt Control		32 (16 point input positive/negative edges)					
	Internal Interrupt Control		8 (1, 2 3, 4, 5, 10, 50, 100mS)					
0.1mS High Speed Timer (HST)		1 (16bits), 4 (32bits, derived from HHSC)						

High Speed Counter	Hardware High Speed Counter (HHSC) /32Points	Channels	Up to 4	<ul style="list-style-type: none"> Total number of HHSC and SHSC is 8. HHSC can change into High Speed Timer with 32 bits/0.1mS Time base.
		Counting mode	8 (U/D, U/D × 2, K/R K/R × 2, A/B, A/B × 2, A/B × 3 A/B × 4)	
		Counting frequency	Up to 100KHz (single-end input) or 920KHz (differential input)	
	Software High Speed Counter (SHSC) /32Points	Channels	Up to 4	
		Counting mode	3 (U/D · K/R · A/B)	
		Counting frequency	Maximum sum up to 10KHz	
Communication Interface	Port0 (RS232 or USB)		Communication Speed 4.8Kbps~921.6Kbps (9.6Kbps)*	Port1~4 talk FATEK or Modbus RTU Master/Slave Communication Protocol
	Port1~Port4 (RS232, RS485 or Ethernet)		Communication Speed 4.8Kbps~921.6Kbps (9.6Kbps)*	
	Maximum Connections		254	
NC Positioning Output (PSO)	Number of Axes		Up to 4	
	Output Frequency		920KHz single output (single or A/B way) 920KHz(single way) and 460KHz(A/B way) differential output.	
	Output Pulse Mode		3 (U/D · K/R · A/B)	
	Positioning Language		Special Positioning Programming Language	
HSPWM Output	Number of Points		Up to 4	
	Output Frequency		72Hz~18.432KHz (with 0.1% resolution) 720Hz~184.32KHz (with 1% resolution)	
Captured input	Points	Max.36 points (all of main units have the feature)		
		> 10 μS (super high speed/high speed input)		
	Captured pulse width	> 47 μS (medium speed input)		
> 470 μS (mid/low speed input)				
Setting of Digital Filter	X0~X15	Frequency 14KHz ~ 1.8MHz		Chosen by frequency at high frequencies
		Time constant 0 ~ 1.5mS/0 ~ 15mS, adjustable by step of 0.1mS/1mS		Chosen by time constant at low frequencies
	X16~X35	Time constant 1mS~15mS, adjustable by step of 1mS		

1.6 Environmental Specifications

Item		Specification	Note	
Operating Ambient Temperature	Enclosure equipment	Minimum	5°C	Permanent Installation
		Maximum	40°C	
	Open equipment	Minimum	5°C	
		Maximum	55°C	
Storage Temperature		-25°C~+70°C		
Relative Humidity (non-condensing, RH-2)		5%~95%		
Pollution Level		Degree II		
Corrosion Resistance		By IEC-68 Standard		
Altitude		≤ 2000m		
Vibration	Fixated by DIN RAIL	0.5G, for 2 hours each along the 3 axes		
	Secured by screws	2G, for 2 hours each along the 3 axes		
Shock		10G, 3 times each along the 3 axes		
Noise Suppression		1500Vp-p, width 1us		
Withstand Voltage		1500VAC, 1 minute	L, N to any terminal	

Warning

The listed environmental specifications are for FBs-PLC under normal operation. Any operation in environment not conform to above conditions should be consulted with FATEK.

1.7 Connection Diagrams of Various Models

1.7.1 NC Control Main Unit [7.62mm Detachable Terminal Block]

- 20 point digital I/O main unit (12 points IN, 8 points OUT)

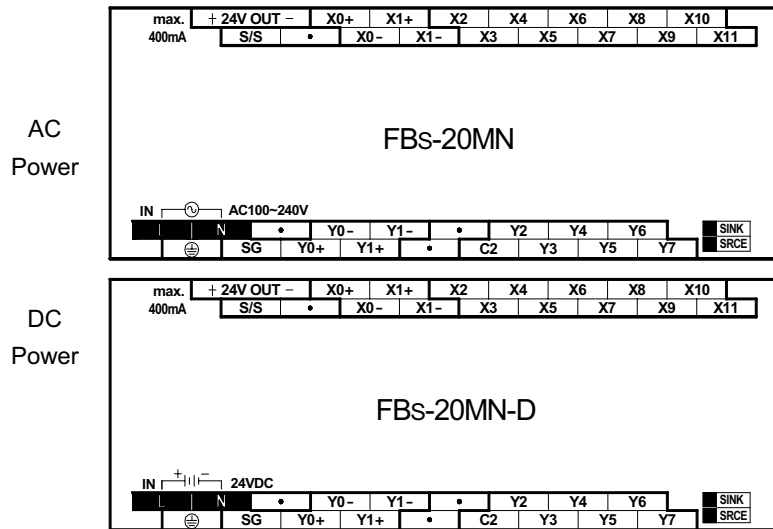

- 32 point digital I/O main unit (20 points IN, 12 points OUT)

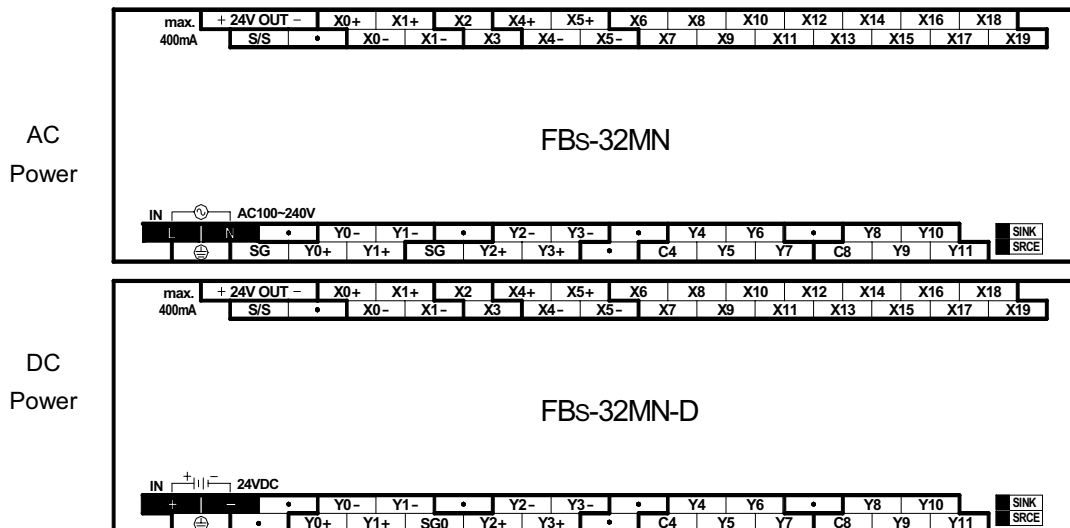

- 44 point digital I/O main unit (28 points IN, 16 points OUT)

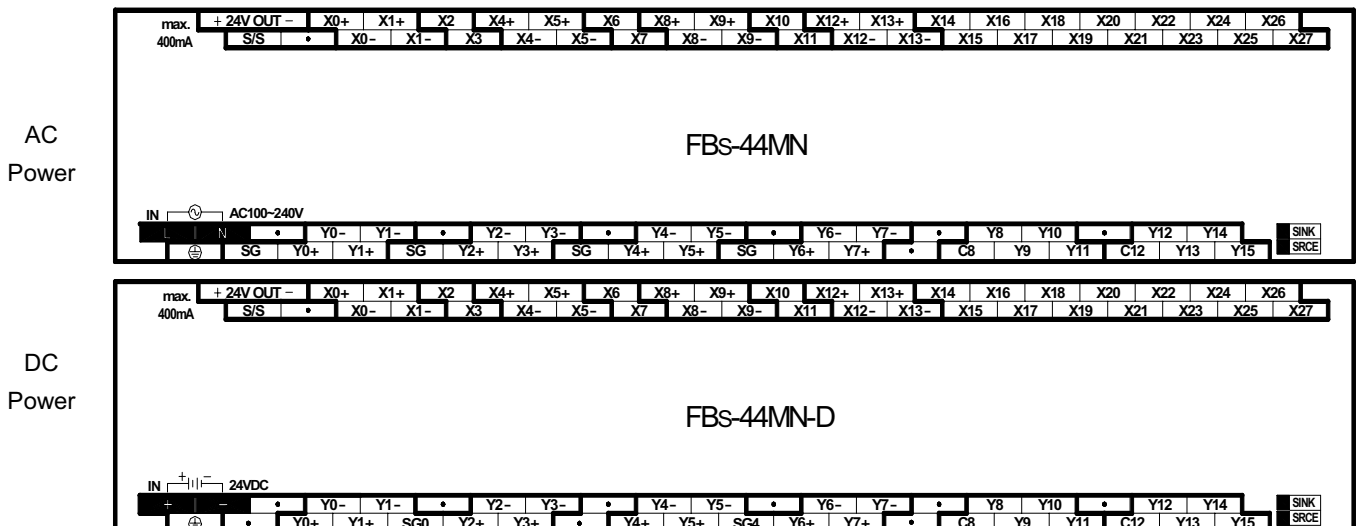

1.7.2 Basic/Advanced Main Unit

[7.62mm Terminal Block, fixed in model MA, detachable in models MC/MN]

- 10 point digital I/O main unit (6 points IN, 4 points OUT)
- 14 point digital I/O main unit (8 points IN, 6 points OUT)

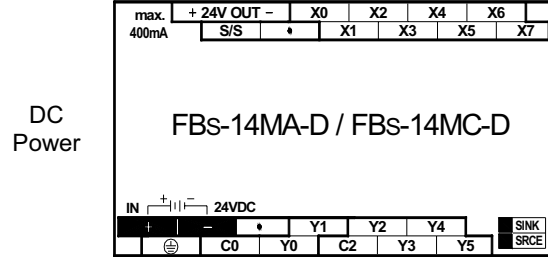
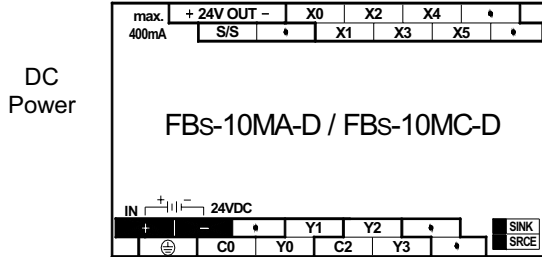
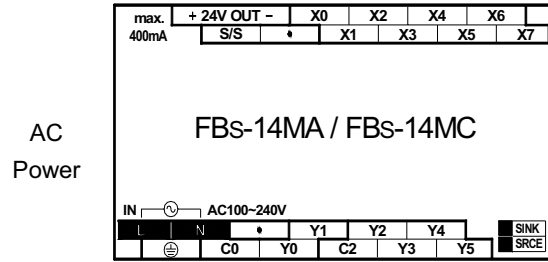
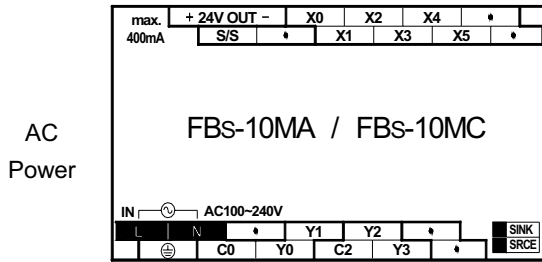

- 20 point digital I/O main unit (12 points IN, 8 points OUT)

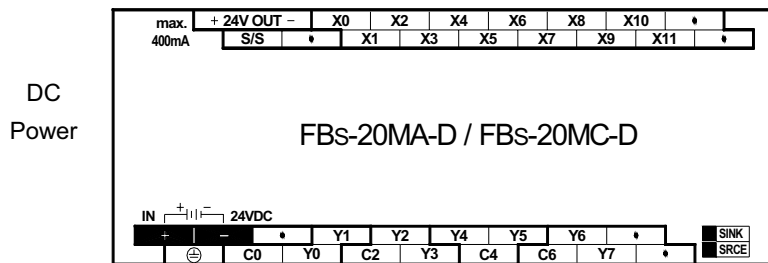
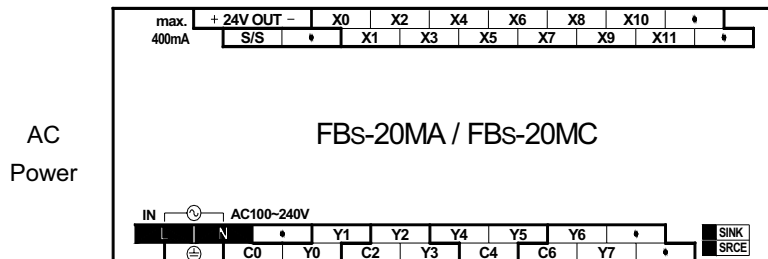

- 24 point digital I/O main unit (14 points IN, 10 points OUT)

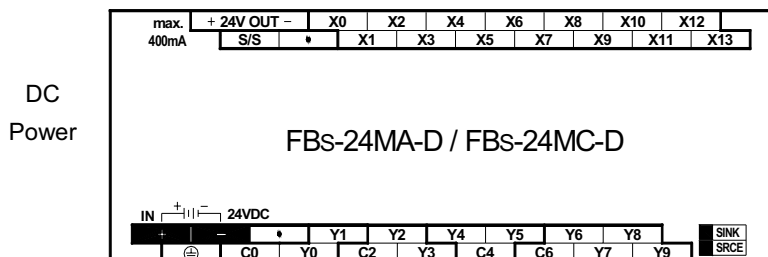
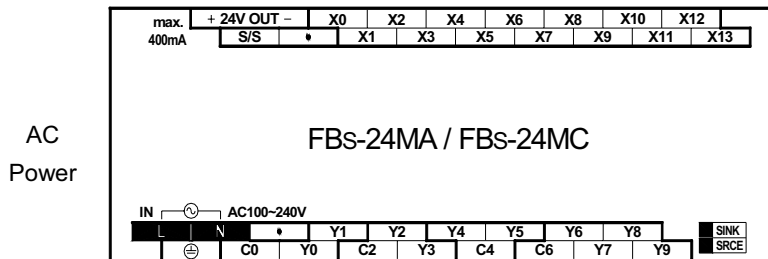

- 32 point digital I/O main unit (20 points IN, 12 points OUT)

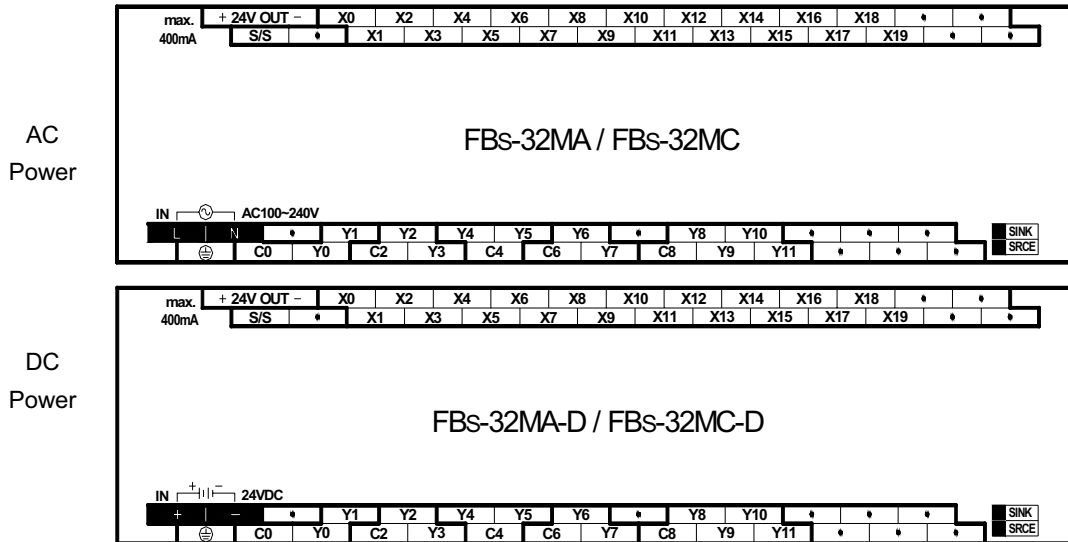

- 40 point digital I/O main unit (24 points IN, 16 points OUT)

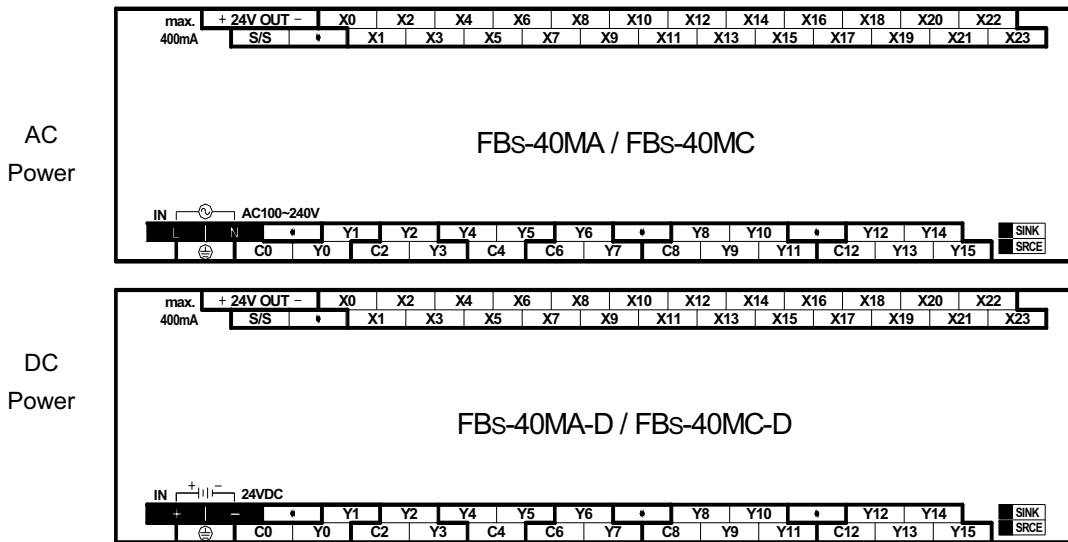

- 60 point digital I/O main unit (36 points IN, 24 points OUT)

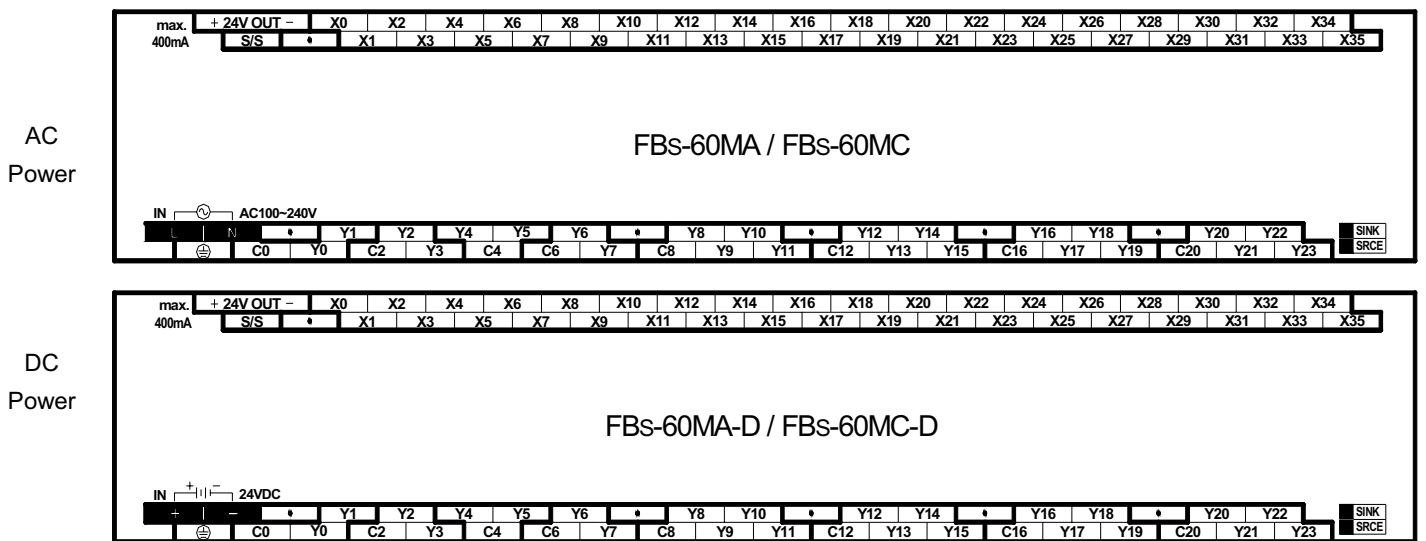

1.7.3 Digital I/O Expansion Unit

[7.62mm fixed terminal block]

- 24 point I/O expansion unit (14 points IN, 10 points OUT)

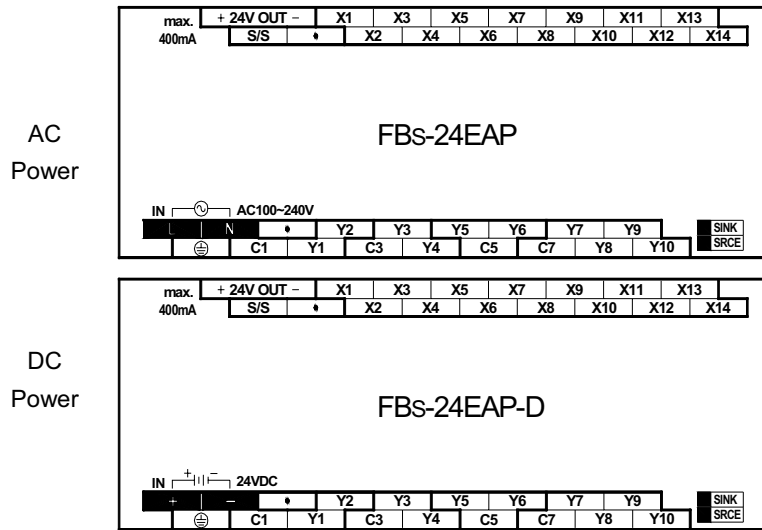

- 40 point I/O expansion unit (24 points IN, 16 points OUT)

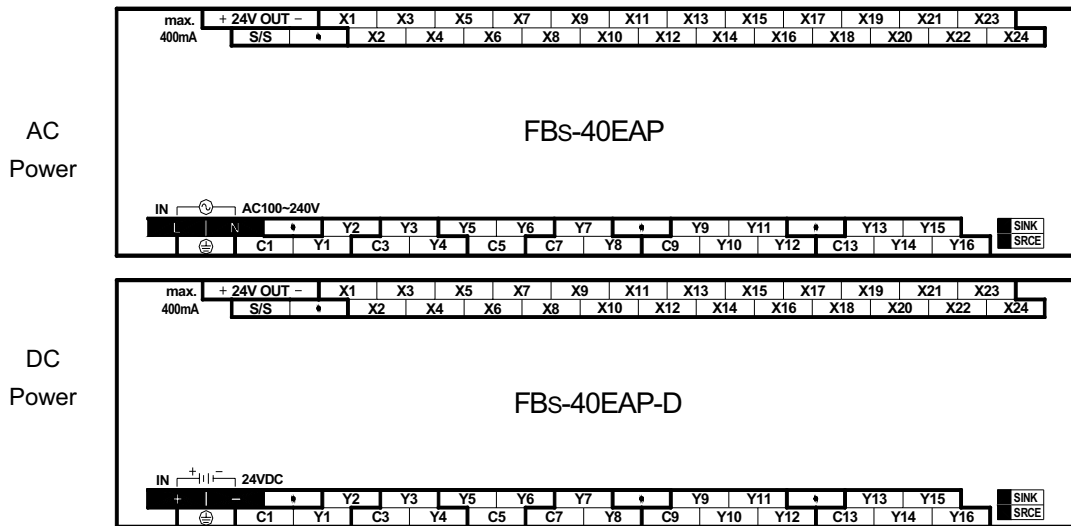

- 60 point I/O expansion unit (36 points IN, 24 points OUT)

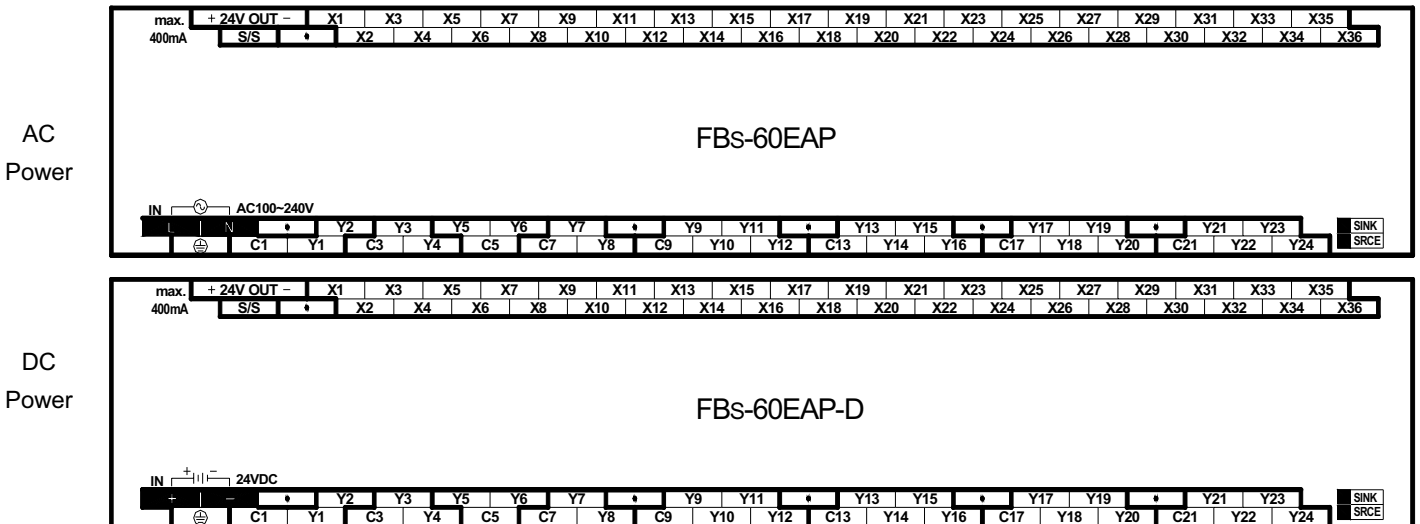

1.7.4 Digital I/O Expansion Module [7.62mm fixed terminal block]

- 8 point digital I/O module (4 points IN, 4 points OUT)
- 8 point digital input module (8 points IN)

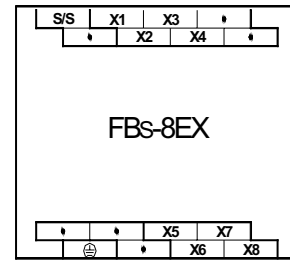
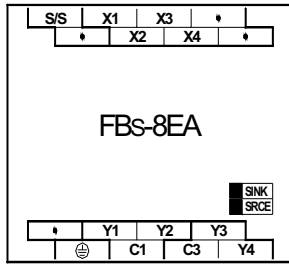

- 8 point digital output module (8 points OUT)

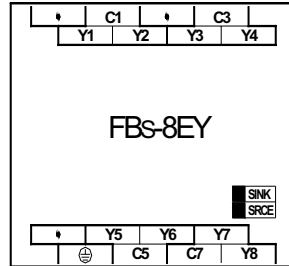

- 16 point digital I/O module (8 points IN, 8 points OUT)

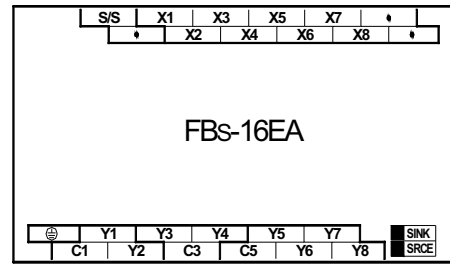

- 20 point digital input module (20 points IN)

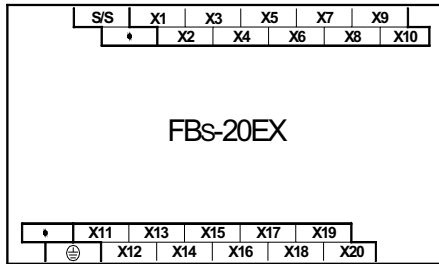

- 16 point digital output module (16 points OUT)

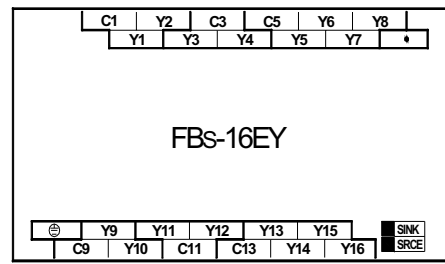

- 24 point digital I/O module (14 points IN, 10 points OUT)

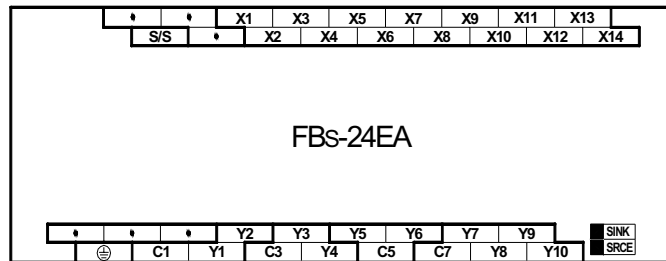

- 40 point digital I/O module (24 points IN, 16 points OUT)

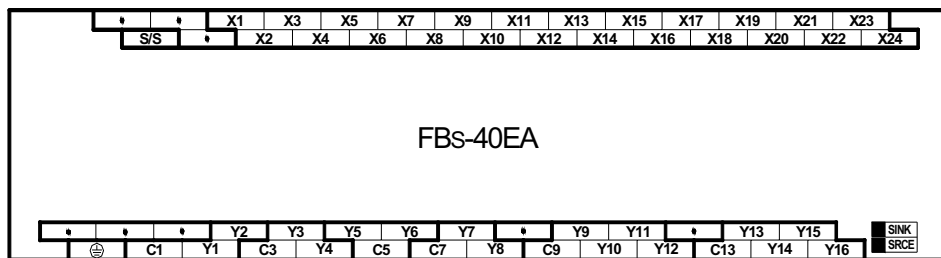

- 60 point digital I/O module (36 points IN, 24 points OUT)

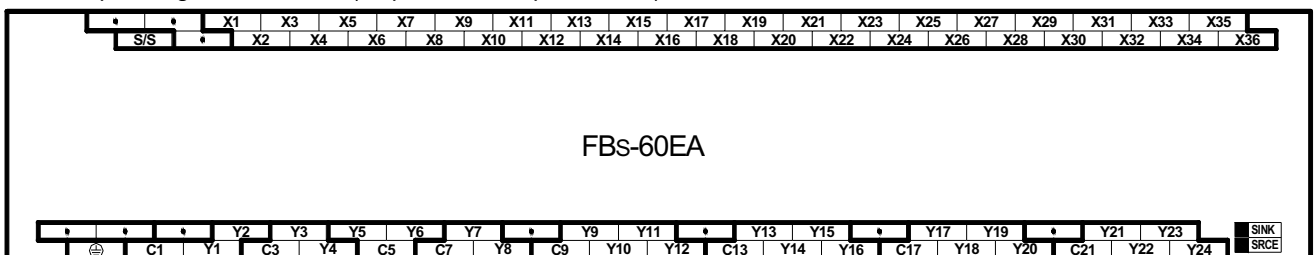

1.7.5 High-Density Digital I/O Expansion Module

[30Pin/2.54mm Header connector]

- 24 point high-density input module (24 points IN)
- 24 point high-density transistor output module (24 points OUT, SINK Type)

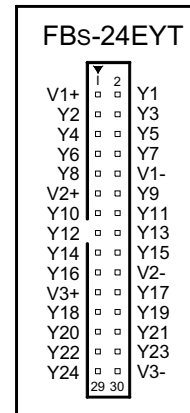
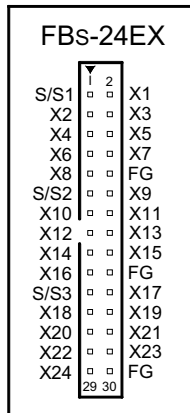

1.7.6 Numeric I/O Expansion Module

[2.54mm Header connector]

- 7 segment LED display module (8 digits/-7SG1, 16 digits/-7SG2) [16 pin/2.54mm Header connector]
- Thumbwheel switch multiplex input module (4 digits×8) [30Pin/2.54mm Header connector]

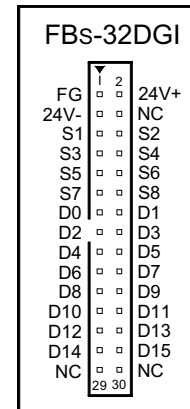
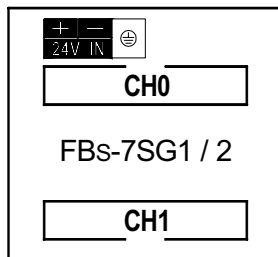

1.7.7 Analog I/O Expansion Module

[7.62mm fixed terminal block]

- 6 channel A/D analog input module
- 2 channel D/A output module

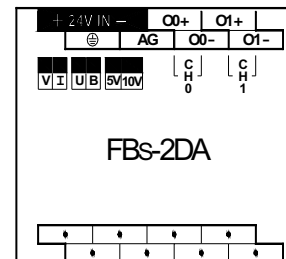
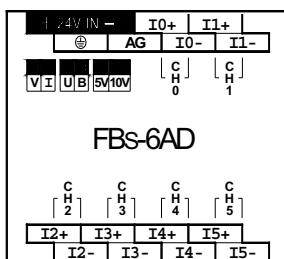

- 4 channel D/A output module

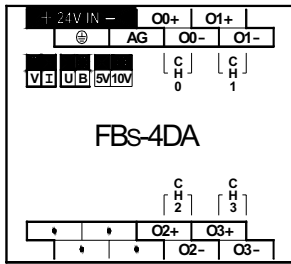

- 4 channel A/D input, 2 channel D/A output module

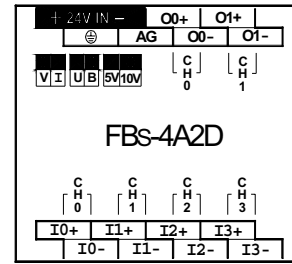

1.7.8 Temperature Input Module

[7.62mm fixed terminal block]

- 2/6 channel thermocouple input module

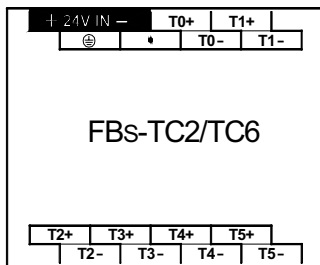

- 16 channel thermocouple input module

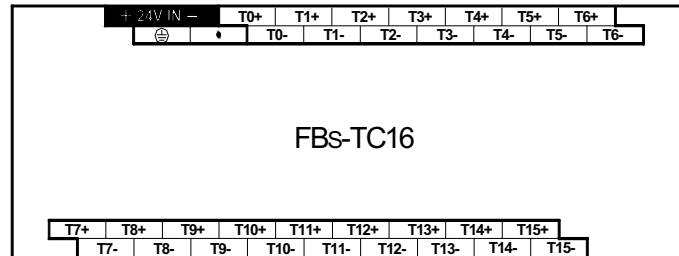

- 6 channel RTD input module

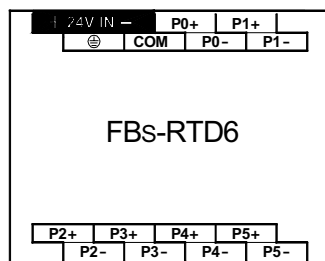

- 16 channel RTD input module

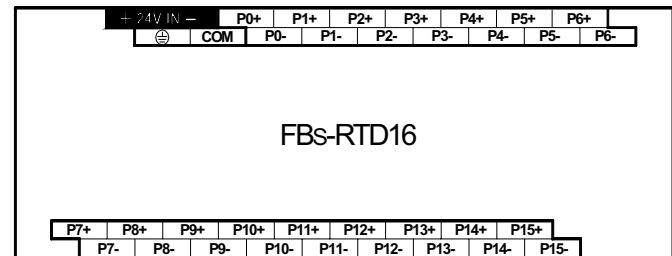

1.7.9 Expansion Power Module

[7.62mm fixed terminal block]

AC
Power

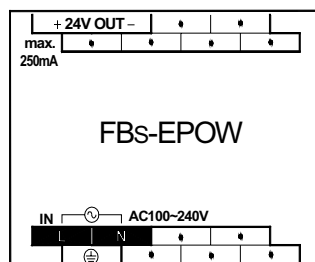

DC
Power

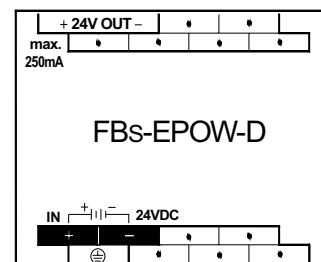

1.7.10 Communication Module (CM)

[DB-9F connector/3Pin or 4Pin Plug able terminal block]

- 2 RS232 ports

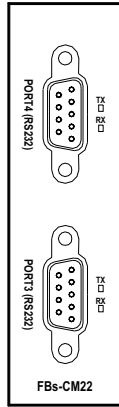

- 2 RS485 ports

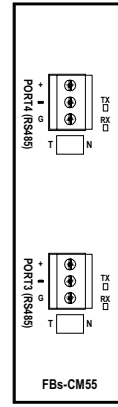

- 1 RS232 + 1 RS485 ports

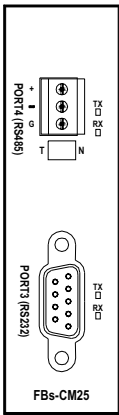

- 1 RS232 + 1 RS485 + Ethernet

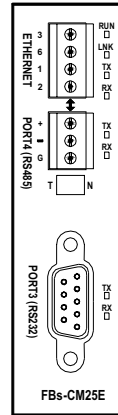

- 2 RS485 ports + Ethernet

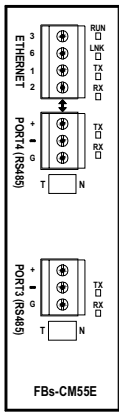

- RS232 ↔ RS485 Converter

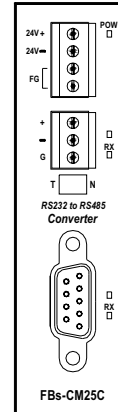

- RS485 Repeater

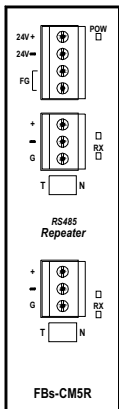

- 4 ports RS485 HUB
(7.62mm fixed terminal block)

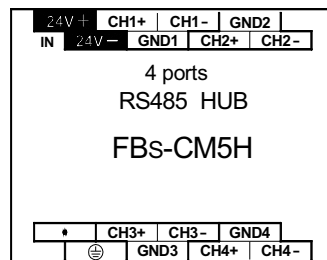

1.7.11 Communication Board (CB)

DB9F/3Pin plug able terminal block (Below are outlooks of CB and the corresponding cover plates)

- 1 RS232 port

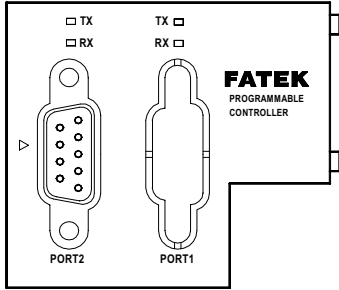

FBS-CB2

- 2 RS232 ports

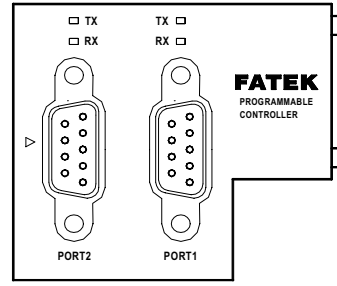

FBS-CB22

- 1 RS485 port

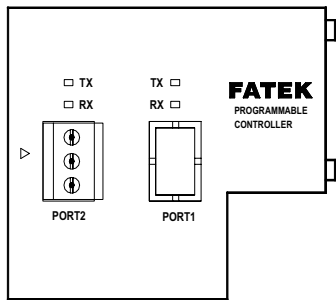

FBS-CB5

- 2 RS485 ports

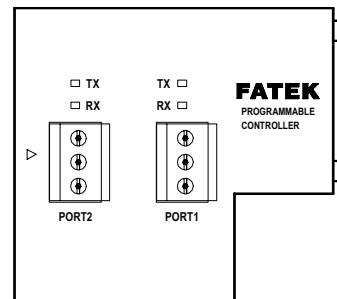

FBS-CB55

- 1 RS232 + 1 RS485 ports

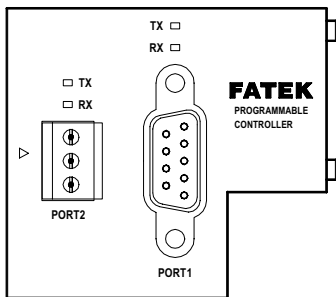

FBS-CB25

- 1 Ethernet port

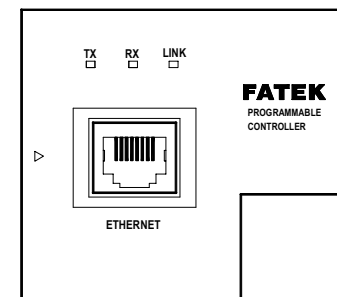

FBS-CBE

1.8 Drawings with External Dimensions

(1) Outlook I :

Main Unit : FBs-10M△, FBs-14M△

Expansion Module : FBs-16E△, FBs-20EX

* (Main Unit and Expansion Module have the same type of base, with different top cover, as shown in the figure)

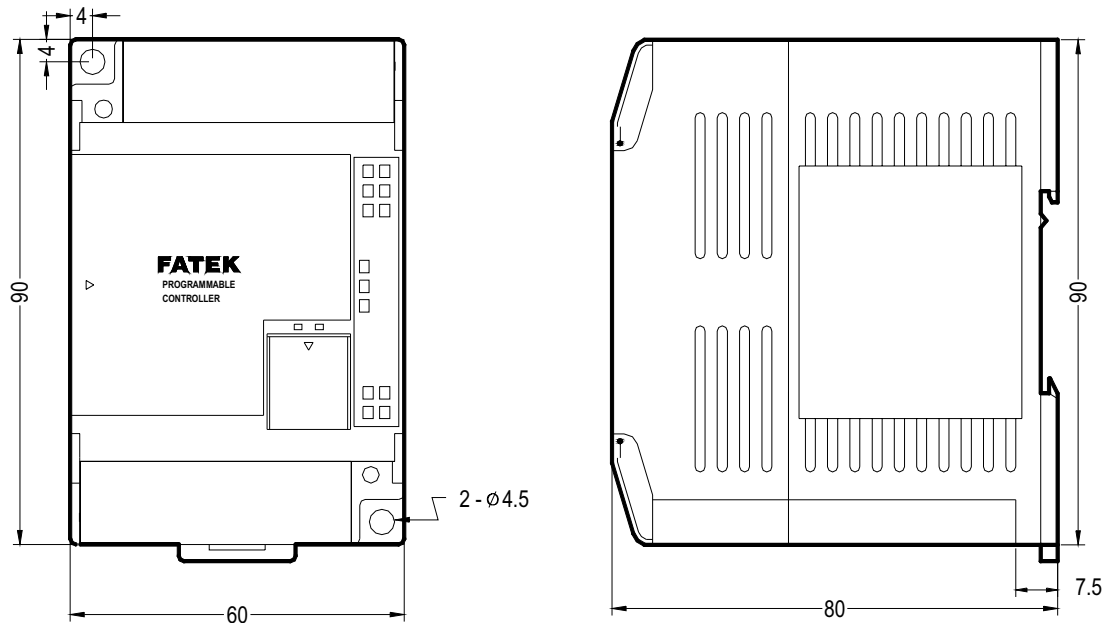

units : mm

(2) Outlook II :

Main Unit : FBs-20M△, FBs-24M△, FBs-32M△, FBs-40M△, FBs-60M△

Expansion Module : FBs-24EA(P), FBs-40EA(P), FBs-60EA(P), FBs-TC16, FBs-RTD16

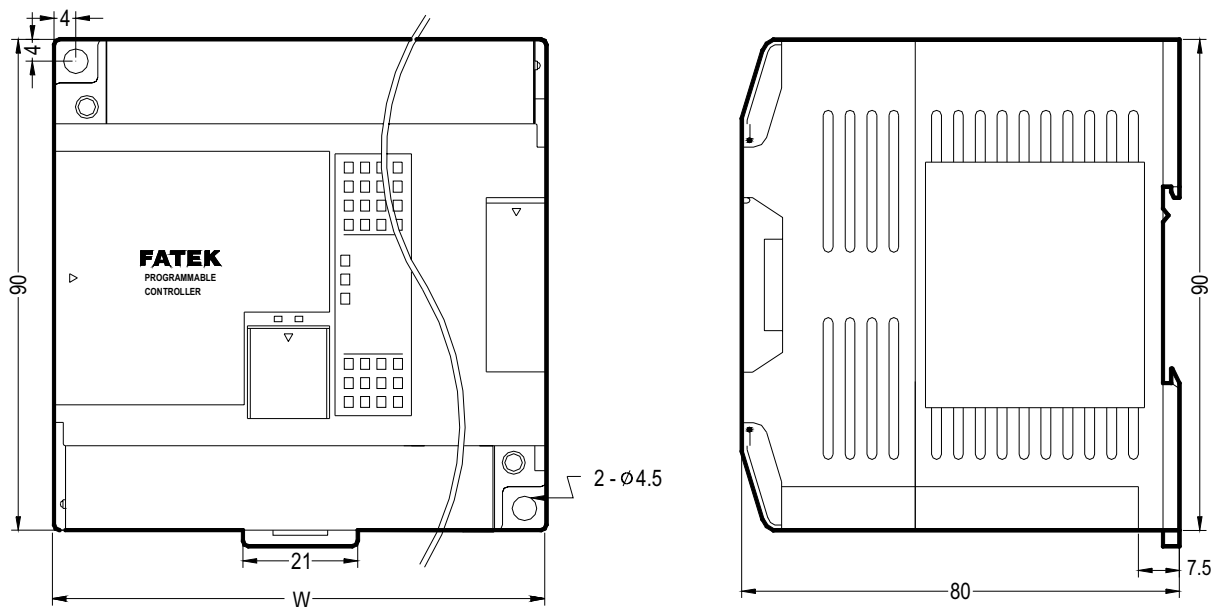

units : mm

W	Model
90mm	FBs-20M△, FBs-24M△, FBs-24EA(P), FBs-TC16, FBs-RTD16
130mm	FBs-32M△, FBs-40M△, FBs-40EA(P)
175mm	FBs-60M△, FBs-60EA(P)

(3) Outlook III :

Expansion Module : ① FBs-8E△, FBs-7SG△, FBs-6AD, FBs-2DA, FBs-4DA, FBs-4A2D, FBs-TC2, FBs-TC6,
 FBs-RTD6, FBs-CM5H
 ② FBs-24EX, FBs-24EYT, FBs-32DGI

* (Modules ① and ② have the same type of base, with different top cover. Top cover of Module ① is shown in the following figure)

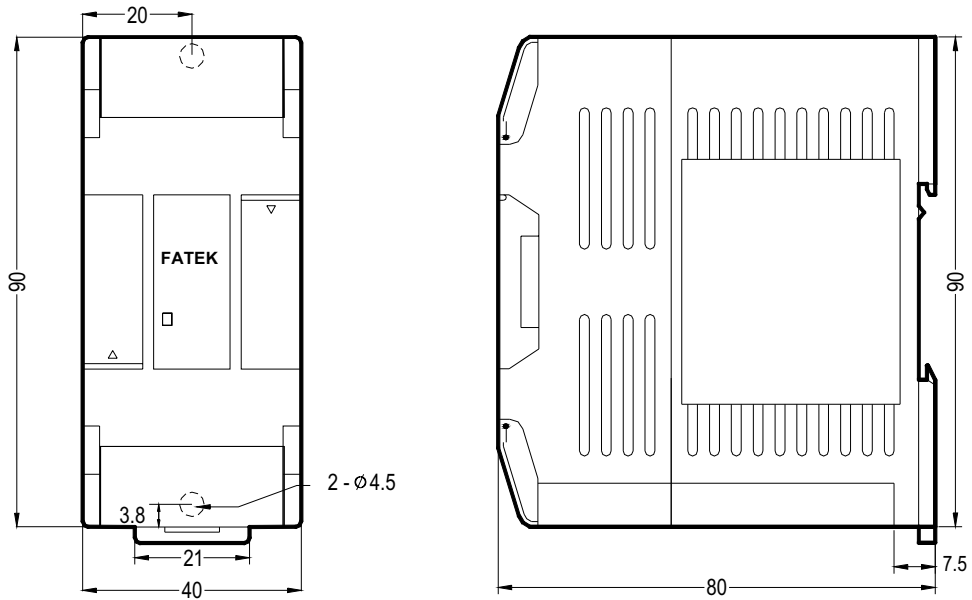

units : mm

(4) Outlook IV

Communication Module : FBs-CM22, FBs-CM55, FBs-CM25, FBs-CM25E, FBs-CM55E, FBs-CM25C, FBs-CM5R

* (All modules have the same type of base, with different top cover. Top cover of Module -CM25E is shown in the figure)

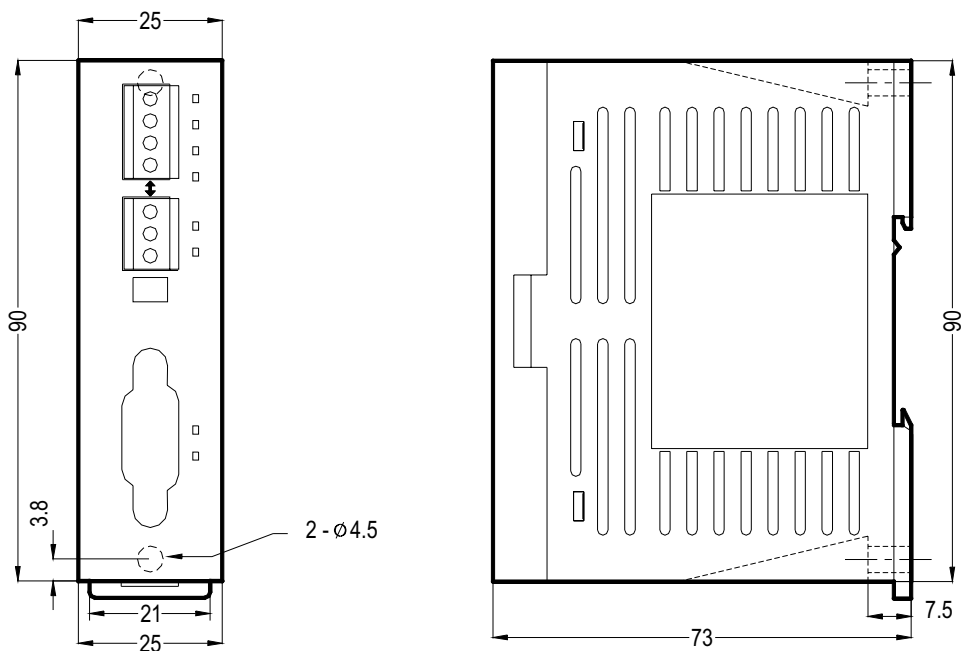

units : mm

- (5) Outlook V :
 Programming Panel : FP-07C

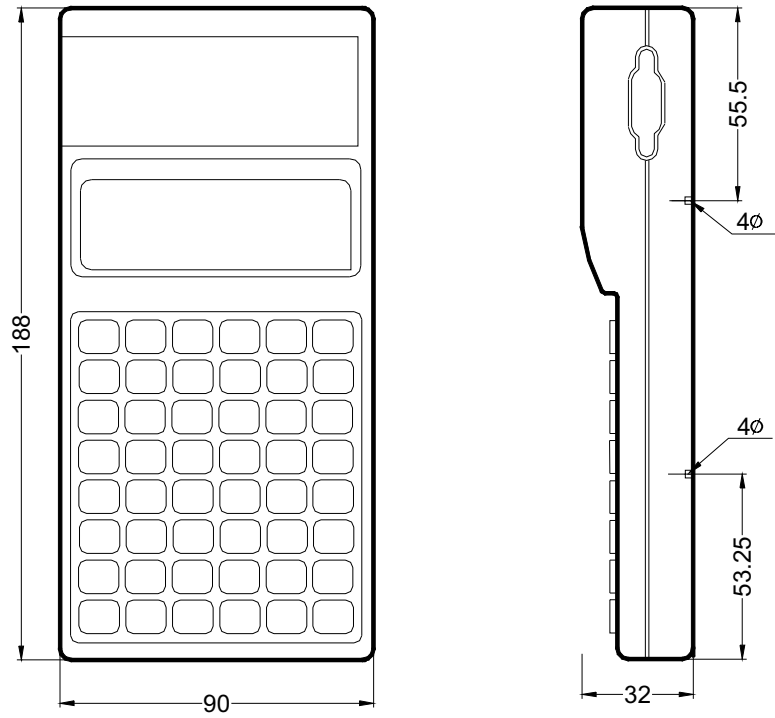

units : mm

- (6) Outlook V :
 Data Access Panel : FB-DAP

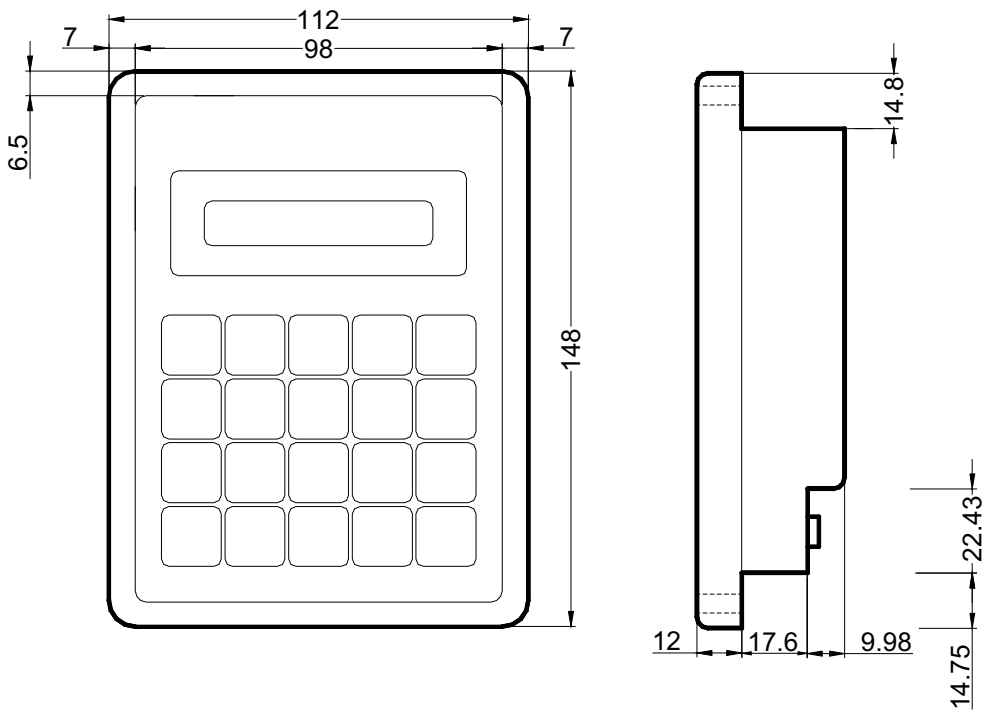

Chapter 2 System Architecture

2.1 Single-Unit System of FBS-PLC

The Single-Unit system means a system built only by a single FBS-PLC and its expansion unit/modules and communication boards/modules. Such system have a limited capability (refer), beyond that capability can incorporate CPU communication via LINK function for expansions (please refer to the next paragraph). The figure below shows the block diagram of the Single-Unit system of FBS-PLC, where, besides the available main units , the available communication peripherals resources and I/O expansion resources are depict on the left and the right respectively.

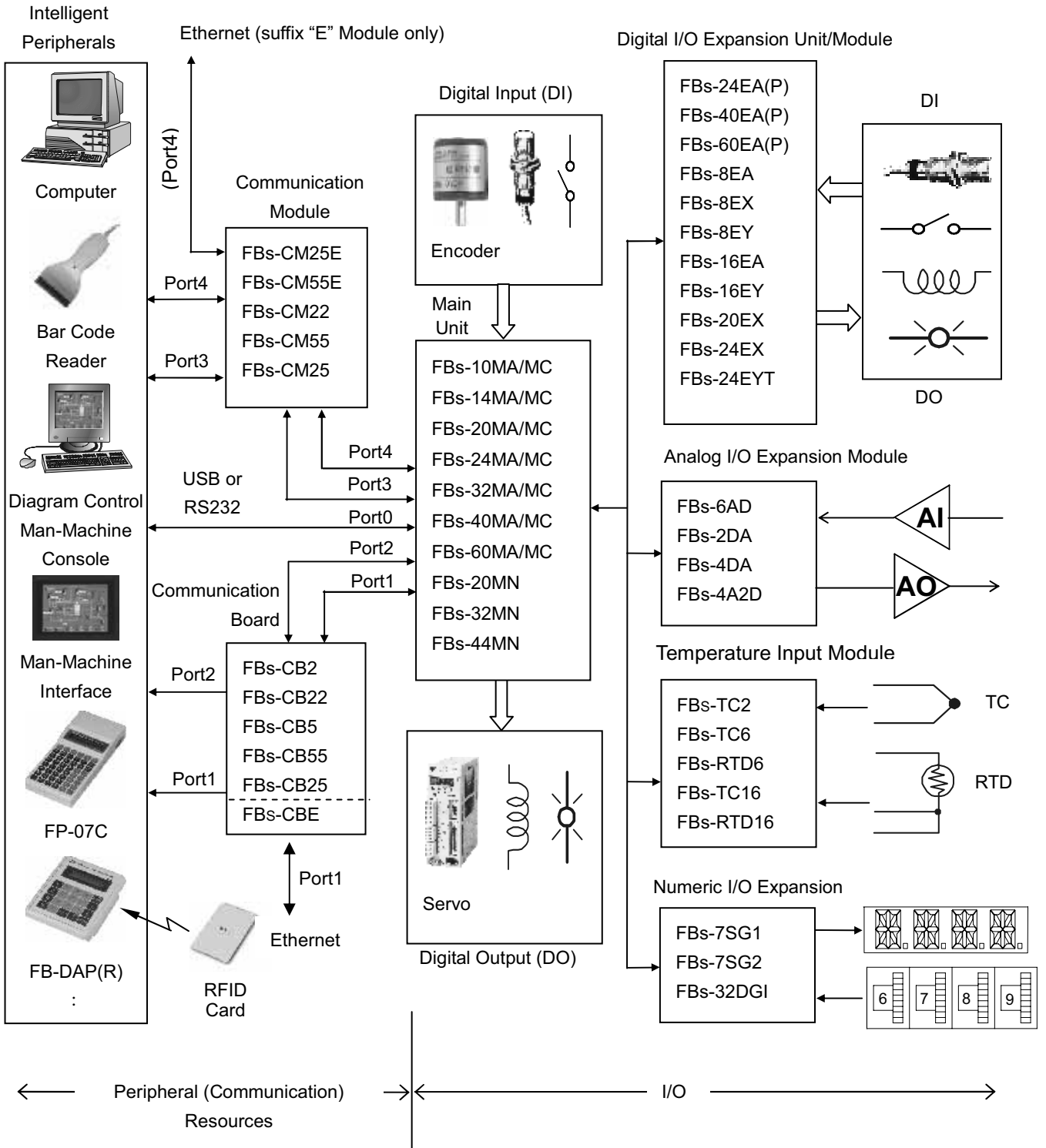

For the I/O of FBs-PLC, it can achieve a maximum of 256 point digital input (DI), 256 point digital output (DO), 64 word numeric input (NI), and 64 word numeric output (NO). Combined with various special interface modules, it can directly connect with devices such as Thermocouple, RTD, 7-segment LED display, and the Thumbwheel switch, which are shown on the right in the above figure.

Regarding communication resources, the FBs-PLC hardware can accommodate up to 5 communication ports (with a maximum speed of 921.6Kbps). In addition to providing the standard FATEK communication protocol, it also supports the Modbus master/slave protocol or any user-defined protocol. This functionality easily renders the connections with intelligent peripherals such as electronic scale, bar code reader, and various meters and gauges.

2.2 Formation of Multi-Unit System

By connections through communication ports and specific communication drivers, multiple Single-Unit PLC systems can be integrated to achieve resources sharing among multiple PLC or PLCs and its host computer. It is described as follows:

2.2.1 Connection of Multiple FBS-PLC (CPU Link)

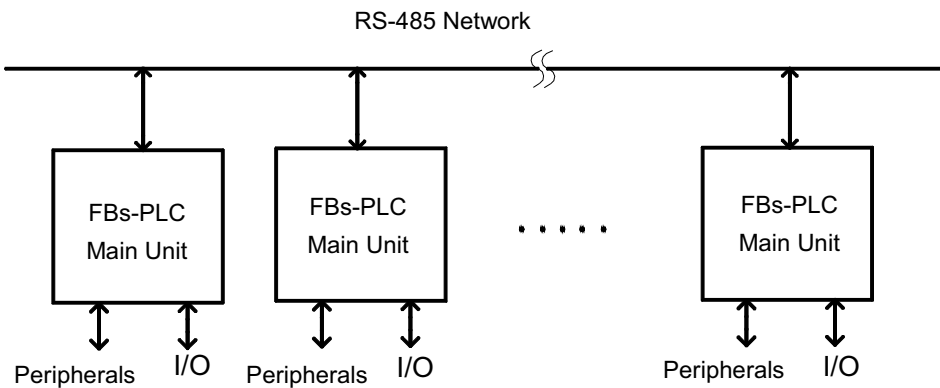

As shown in the figure, through the usage of high-speed RS-485 network, can easily establish the connections of 2~254 main units (each PLC with its own station number). All need to do is to write and execute CPU Link commands in one of the main units, which makes it the Master of the CPU Link network. No other command is necessary for other Slave units. The Master CPU will automatically collect the information or data in the specific areas of all units (including the Master) and put it into the Common Data areas(CDM) of all units. Thus all the units connected by network can share the data for each other and turning the finite Single-Unit system with limited I/O into a huge system.

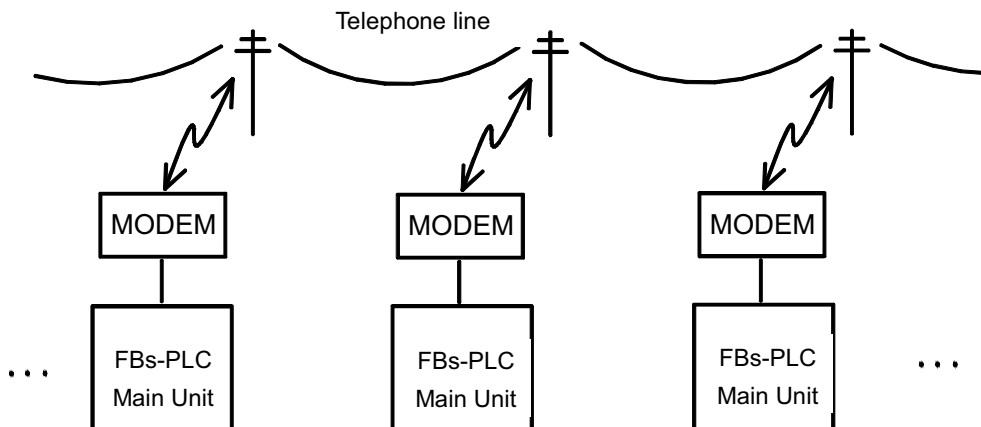

Besides the above area network connection, FBs-PLC can also be connected using MODEM via the phone line (either leased line or public phone line) to form remote multiple PLC Link. (When using a public phone line, the Master PLC will perform consecutive dialing for all its Slave PLC.)

2.2.2 Connection FBs-PLC with Host Computer or Intelligent Peripherals

Any one of the five communication ports on FBs-PLC can be used to connect to an upper-level computer or other systems, with this architecture, the FBs-PLC is playing the Slave role. FBs-PLC supports the FATEK and Modbus protocol. Connection can be established as long as the upper-level computer or intelligent peripherals use either one of the two protocols. In the application, in which driver for FATEK or Modbus is not available, FATEK also provide standard DDE communication server, which enables FBs-PLC to connect with any computer system supporting DDE. The following is the block diagram.

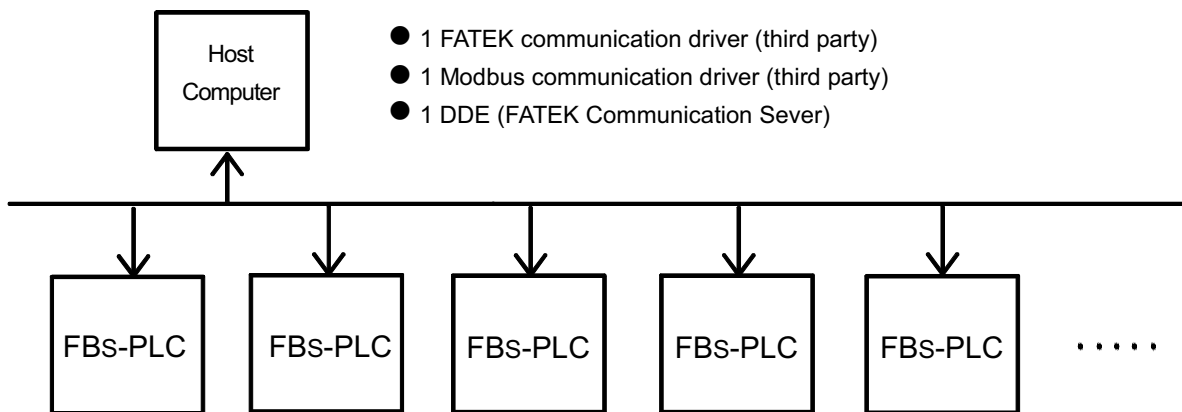

Chapter 3 Expansion of FBS-PLC

If the I/O point of the Main unit of the applied FBS-PLC is not enough for a specific application, then can expand it with the additional expansion units/modules. Besides I/O point there also have the requirements to expand the communication port in some occasions.

3.1 I/O Expansion

The expansion of FBS-PLC I/O consists of Digital I/O (DI/O, which status is represented by a single bit) and the Numeric I/O (NI/O , which status is represented by a 16-bit Word). Either the DI/O or the NI/O expansion is realized through expansion units or modules cascaded thru the usage of the “I/O Output Expansion Connector” located at the right side of FBS-PLC or expansion unit/ module.

The I/O points of FBS-PLC system are limited to 512 points of DI/O (256 points for DI and DO, respectively), 128 words of NI/O (64 words for NI and NO, respectively). Besides this there are two limits imposed by hardware: ①. A maximum number of 32 units or modules can be used in the expansion. ②. The total length of the expansion cables cannot exceed 5 meters.

Note

1. If the I/O points of the application system exceed one of the limitations(256 DI,256 DO,64 NI, 64 NO), while startup the main unit of FBS-PLC will treat this as an illegal I/O configuration, which in return will flag as an error situation by turn on the “ERR” LED and put the error code in Y0~Y3 LED(refer the page 8-2, Chapter 8). The corresponding error code will also be indicated in the CPU status register (R4049).
2. The maximum number of expansion units/modules of FBS-PLC is 32. Beyond this numbers will be treated as an invalid I/O configuration and the main unit will stop its operation, which in return will flag as an error situation by turn on the “ERR” LED and put the error code in Y0~Y3 LED(refer the page 8-2, Chapter 8). The corresponding error code will also be indicated in the CPU status register (R4049).

Warning

1. The maximum length of the I/O expansion cable for FBS-PLC is 5 meters. Cables longer than that will cause incorrect I/O operation because of excess signal delay in hardware or noise pickup, resulting in damage to equipment or posing hazard to operating personnel. Since this kind of situation cannot be detected by the PLC main unit, users are advised to take extra cautions and necessary measures.

3.1.1 Digital I/O Expansion and I/O Numbering

Digital I/O means I/O with the discrete type status, including digital input (with initial X in DI numbering) and digital output (with initial with Y in DO numbering). The DI and DO of FBS-PLC can both be expanded up to 256 points (numbered as X0~X255 and Y0~Y255, each with 256 points).

The status of input contacts (X0~X255) of PLC come from the input signal connected to the digital input terminal block on main unit or expansion unit/module; while the status appears at digital output terminal block of main unit and expansion unit/module reflects the digital output relay (Y0~Y255) status inside PLC.

On FBS-PLC main unit, at the position below the digital input terminal block and the position above the output terminal block, there have labels indicate the corresponding signal name. They label each terminal with numbers representing the corresponding digital input contact Xn and digital output relay Yn. In the example of the main unit in FBS-24MC, the corresponding digital input contacts on the input terminal block are labeled X0~13, and the corresponding digital output relays on the output terminal block Y0~Y9. Users only need to locate the printed label for each terminal to find out its I/O number. The LED status display region also indicates the ON/OFF status for all DI(X0~X13) and DO(Y0~Y9) on the

main unit. Users can easily find each terminal with its I/O number and LED status indication, as shown in the figure below using X10 and Y6 as an example:

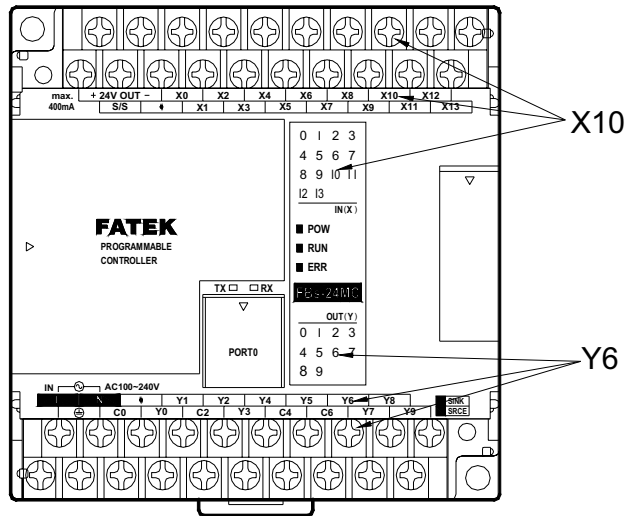

While the various expansion units/modules other than the main units have the same printed labels on the input/output terminals as the main units do, these labels are only relative I/O numbers, different from the absolute I/O numbers on main units. The number of a terminal only represents its order on the expansion unit/module. For example, the first contact is X1 or Y1, the second X2 or Y2, etc. All numbers on the expansion unit/module begin with 1. The actual number of digital input contact or the output relay, however, is determined by summing the numbers on all previous expansion units/modules and the main unit. See the following figure and its calculation.

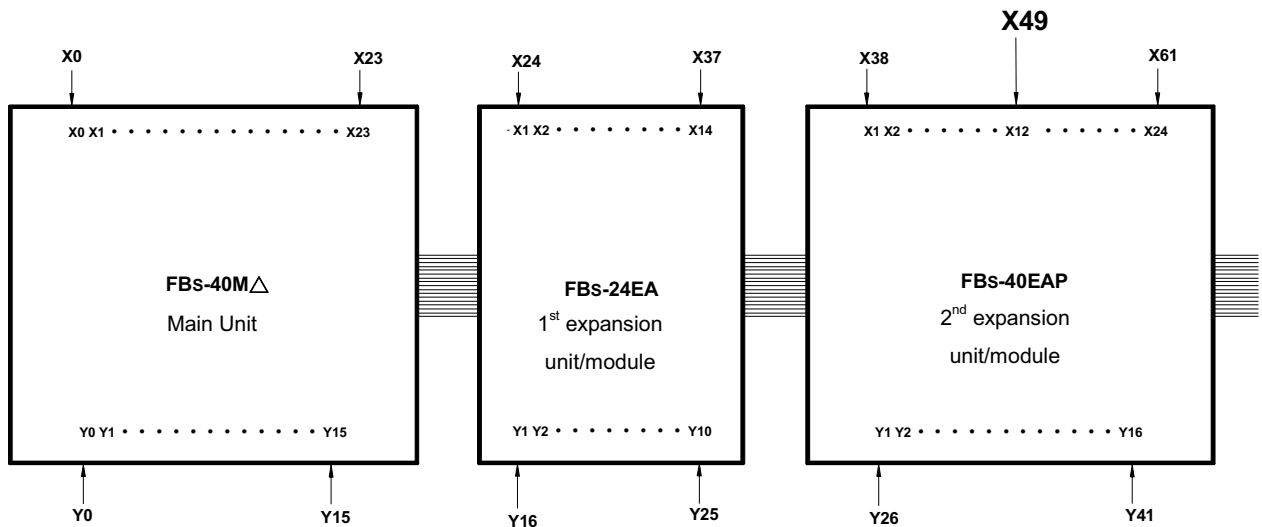

As shown in the above figure, because the top X numbers of the previous two units are 23 and 14, respectively, the number of input contact X12 on second expansion unit should be:

$$X(23+14+12) = X49$$

3.1.2 Numeric I/O Expansion and I/O Channel Mapping

The numeric I/O in FBs-PLC treat 16 single-bit data as one 16-bit numeric data (Word) ranging from the 0~65535. Since all numeric data of FBs-PLC are stored in the register inside PLC (16-bit width), therefore numeric I/O is also called register I/O. The Input Register (IR) has 64 Word (R3840 ~ R3903) for inputs from external numeric input (NI) module, and the Output Register (OR) also has 64 Word (R3904 ~ R3967) for outputs to external numeric output (NO) module.

Analog Input Module, Temperature Module, and Thumbwheel switch multiplex input module are of Numeric input (NI) modules which use input register (IR) to convey the status. Analog Output Module, 7 Segments Display Module are of Numeric output (NO) modules which output is directly from the Output register (OR). The Analog Input, Temperature Input, and Analog Output is of analog voltage or current, while the Thumbwheel switch Input or 7 Segments Display Output uses user-friendly BCD number signal. Either the magnitude of voltage or current or the value of BCD number is represented by the 16-bit value of the corresponding register. The corresponding current/voltage signal or BCD value of any IR or OR on the NI/O module is named as a Channel (CH). The channels on the NI module are called numeric input channels (NI channels) and those on NO module numeric output channels (NO channels). The number of IR/OR used by NI and NO channels on each module varies depending on the module type or working mode. The following table lists the numbers of IR and OR used by NI and NO channels on each NI/O module:

NI/O Module Name	NI Channel Label	NO Channel Label	Number of IR occupied (Word)	Number of OR occupied (Word)	Note
FBs-6AD	CH0		1		
	CH1		1		
	CH2		1		
	CH3		1		
	CH4		1		
	CH5		1		
FBs-2DA		CH0		1	
		CH1		1	
FBs-4DA		CH0		1	
		CH1		1	
		CH2		1	
		CH3		1	
FBs-4A2D	CH0		1		
	CH1		1		
	CH2		1		
	CH3		1		
		CH0	1		
		CH1	1		
FBs-32DGI	Unlabeled		8		1 CH only
FBs-7SG1		CH0		3(D) 4(ND)	D : decode mode ND : non-decode mode
FBs-7SG2		CH0		3(D) 4(ND)	
				CH1	
FBs-TC2			1		1 CH only
FBs-TC6/RTD6	Unlabeled		1		1 CH only
FBs-TC16/RTD16	Unlabeled		1		1 CH only

The corresponding IR or OR number calculation of the NI/O module starts from the first expansion unit/module(main unit itself does not have any NI/O). The first NI channel corresponds to the first IR register (R3840). Adding R3840 with the number of IR used by the first NI channel gives the IR number of the second NI channel. Adding the IR number of the second NI channel with the number of IR used by the second NI channel gives the IR number of the third NI channel. All other R numbers can be obtained accordingly. Similarly, the first NO channel corresponds to the first OR register (R3904). Adding R3904 with the number of OR used by the first NO channel gives the OR number of the second NO channel. (In the cumulative calculation of NI channels, care only for NI channels and disregard DI/O and NI. Similarly, in the case of NO channels, disregard DI/O and NI channels.) The following figure helps users find out the relation between NI/O channels and PLC's IR and OR.

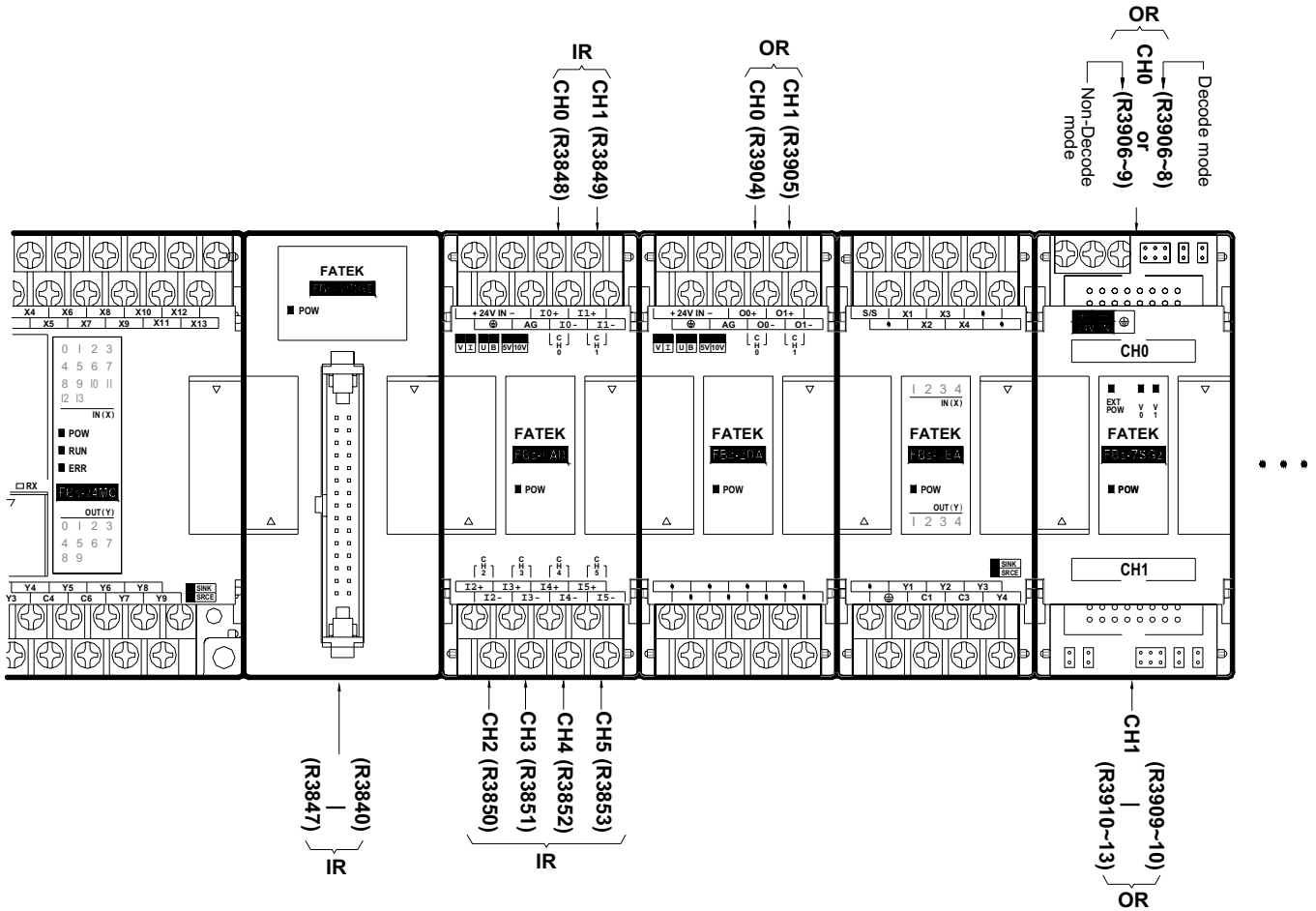

During the startup stage, FBs-PLC will automatically detect the types and CH numbers of expansion units/modules. While operation, the FBs-PLC will read the CH input values from the NI module and stores them into corresponding IR(R3804 ~ R3903) and outputs OR values (R3904~R3967) to channels on the NO module. No pre-configuration or setting by users is required.

3.2 Expansion of Communication Port

The main unit of FBs-PLC has one built-in communication port (port 0, with optional USB or RS232 interface). Expansion of communication ports can be achieved by employing Communication Board (CB) or Communication Module (CM). The available models of CB and CM for FBs are :

	Model Number	Specifications
Communication Board (CB)	FBs-CB2	1 RS232 (port2) communication board
	FBs-CB22	2 RS232 (port1 & port2) communication boards
	FBs-CB5	1 RS485 (port2) communication board
	FBs-CB55	2 RS485 (port1 & port2) communication boards
	FBs-CB25	1 RS232 (port1) + 1 RS485 (port2) communication board
	FBs-CBE	1 Ethernet communication board
Communication Module (CM)	FBs-CM22	2 RS232 (port3 & port4) communication modules
	FBs-CM55	2 RS485 (port3 & port4) communication modules
	FBs-CM25	1 RS232 (port3) + 1 RS485 (port4) communication expansion module
	FBs-CM25E	1 RS232 (port3) + 1 RS485 (port4) communication module with Ethernet
	FBs-CM55E	1 RS485 (port3) + 1 RS485 (port4) communication module with Ethernet

Communication boards, which can be directly installed on FBs main units, are employed for expansion of communication ports port1 and port2. Communication modules are independent modules used for the expansion of communication ports port3 and port4 and need to be mounted against the left side of FBs main unit and connected to the main unit via a 14pin connector. The labels of communication ports are marked on the cover plate of communication boards and modules, from which users can easily identify each port. Except that the built-in communication port (Port0) can only be used for USB or RS 232 interface, all the other ports (Port 1~4) can be used for RS232 or RS 485 interface in CB and CM. The following figure shows an example of expansion of 5 (maximum allowed number) communication ports (CB22+CM25E):

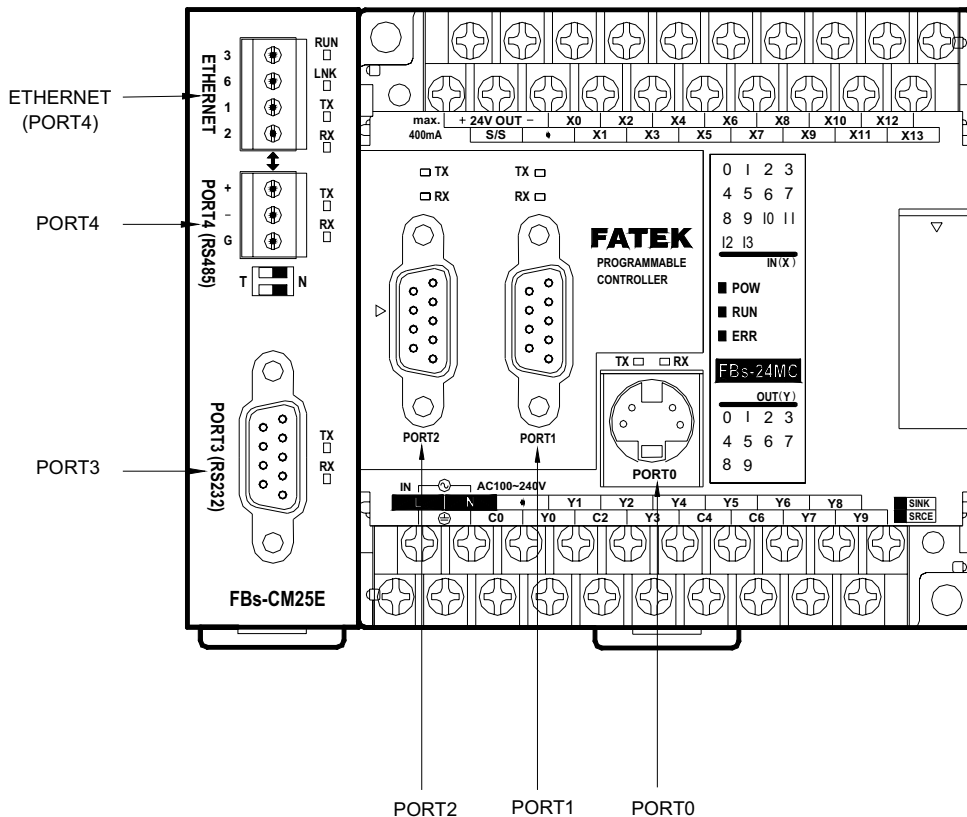

Chapter 4 Installation Guide

Danger

1. Turn off all power during installation of FBS-PLC or related equipments to prevent electric shock or damage to equipment.
2. Upon completion of all installation wiring, put the protective cover back on the terminal block before turning on the power to avoid electrical shock.
3. During installation, never remove the dust cover sheet that were surrounded the PLC before wiring is completed to avoid complications such as fire hazards, breakdown, or malfunction caused by drill dust or wire shreds falling inside PLC.
4. Upon completion of installation and wiring, remember to remove the dust cover sheet to avoid fire, breakdown or malfunction, caused by overheating.

4.1 Installation Environment

Note

1. Environmental specifications of FBS-PLC cannot exceed those listed in this manual. In addition, do not operate this equipment in environments with oil smoke, conductive dust, high temperatures, high humidity, corrosion gases, inflammable gases, rain or condensation, and high vibrations and shock.
2. This product has to be housed appropriately whether it's used in a system or standalone. The choice and installation of housing must comply with local national standards.

4.2 Precautions of PLC Installation

To avoid interference, the PLC should be installed to keep from noise sources such as high- voltage or high-current lines and high power switches. Other precautions are:

4.2.1 Placement of PLC

Fixation of FBS-PLC, which can be fixed by DIN RAIL or screws, should place vertically and start from the main unit on the left to the expansion unit on the right. A typical figure of placement is shown below:

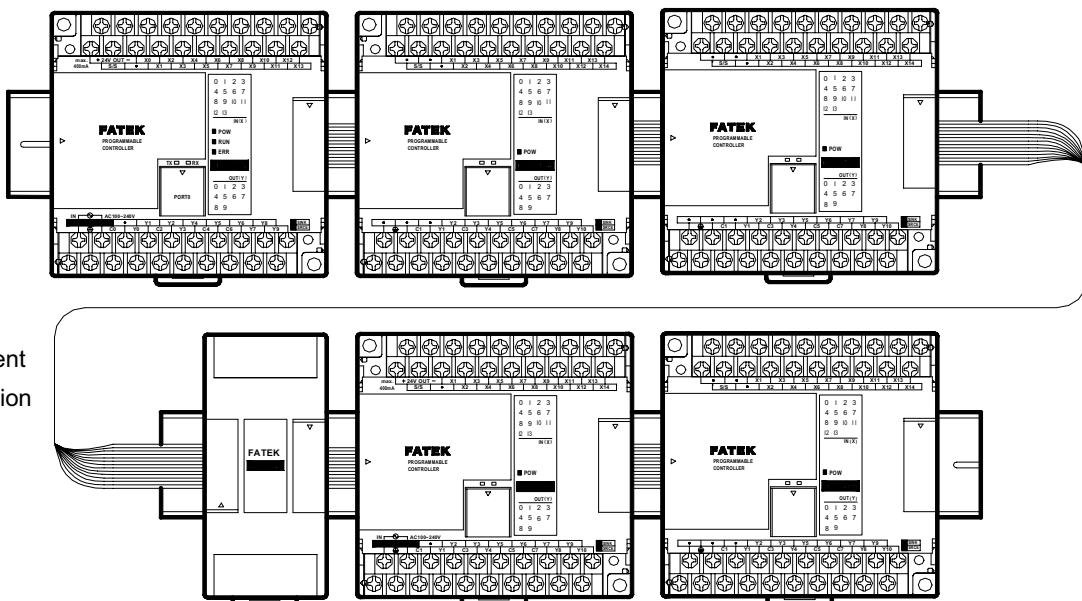

Suggested arrangement of multiple unit expansion

4.2.2 Ventilation Space

The heat in FBs-PLC is ventilated via air circulation. There should reserve more than 20mm space, both below and above PLC, and with vertical installation, for ventilation. as shown in the figure below:

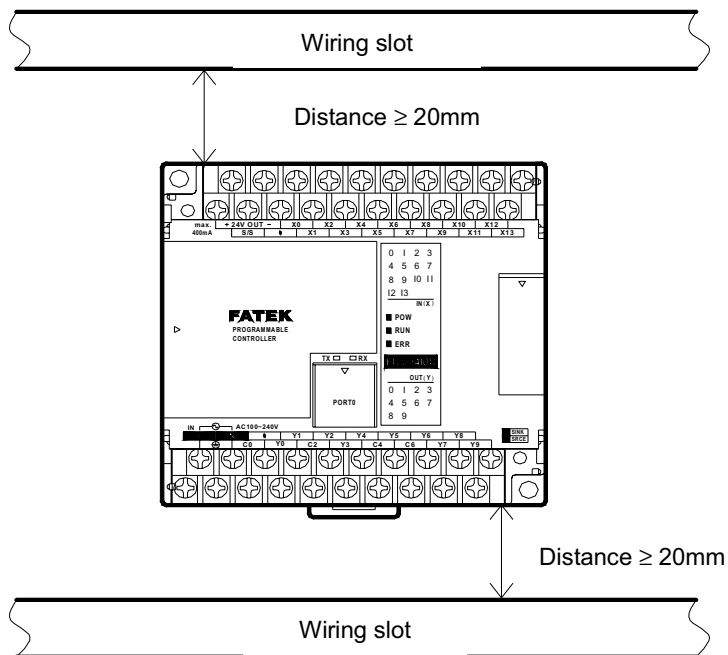
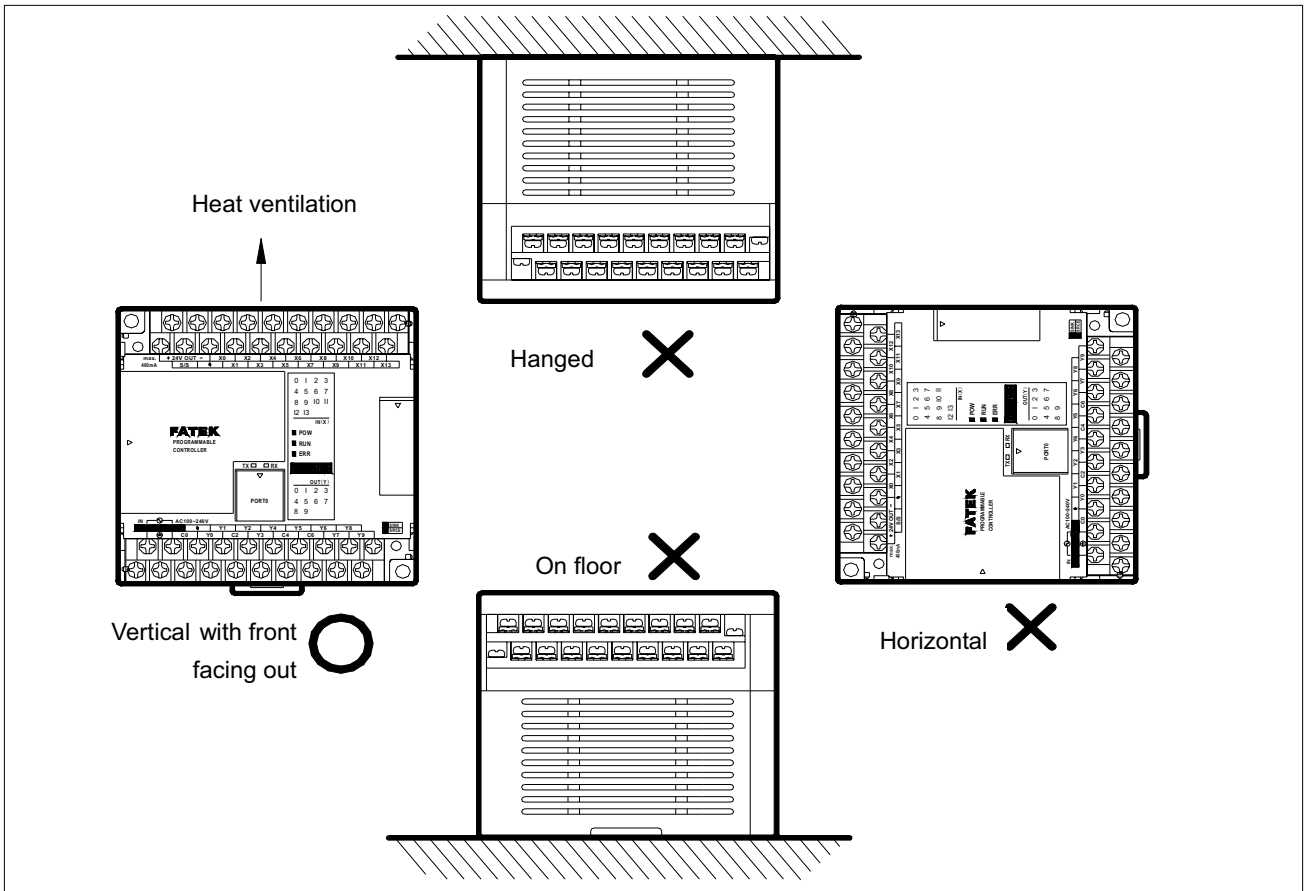

4.3 Fixation by DIN RAIL

In an environment with slight vibration (less than 0.5G), this is the most convenient way of fixation and is easy for maintenance. Please use DIN EN50022 DIN RAIL, as shown in the figure below.

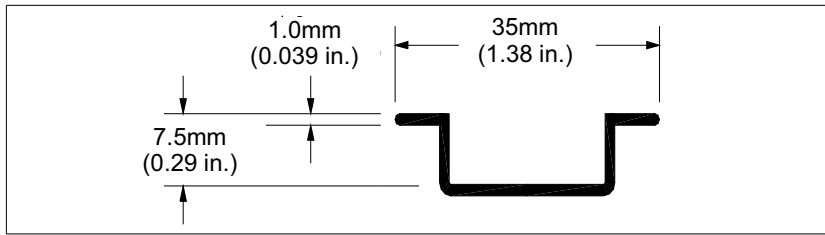

Mount ⇒ Hold PLC facing its front, press it down with a 15 degree tilt onto the DIN RAIL. Swing it down until the upper edge of DIN RAIL groove on PLC back touches the upper tab of DIN RAIL. Then use this locked-in point as a pivot to press the PLC forward on the bottom and lock it in position. The procedure is illustrated below:

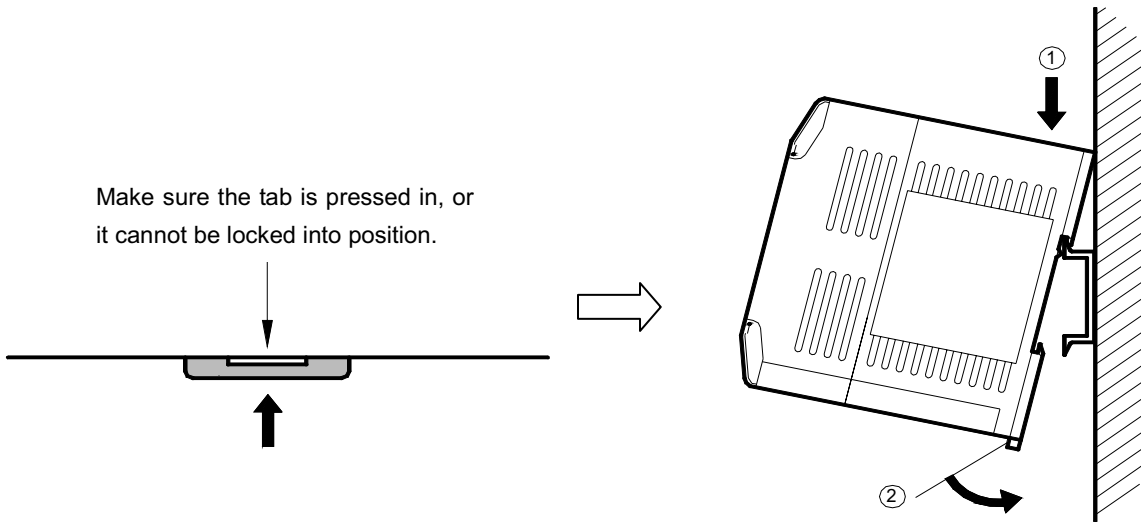

Dismount ⇒ Use a long screwdriver to reach in the hole on the DIN RAIL tab. Pull out the tab to "pulled out" position to remove PLC, as shown in the figure below.

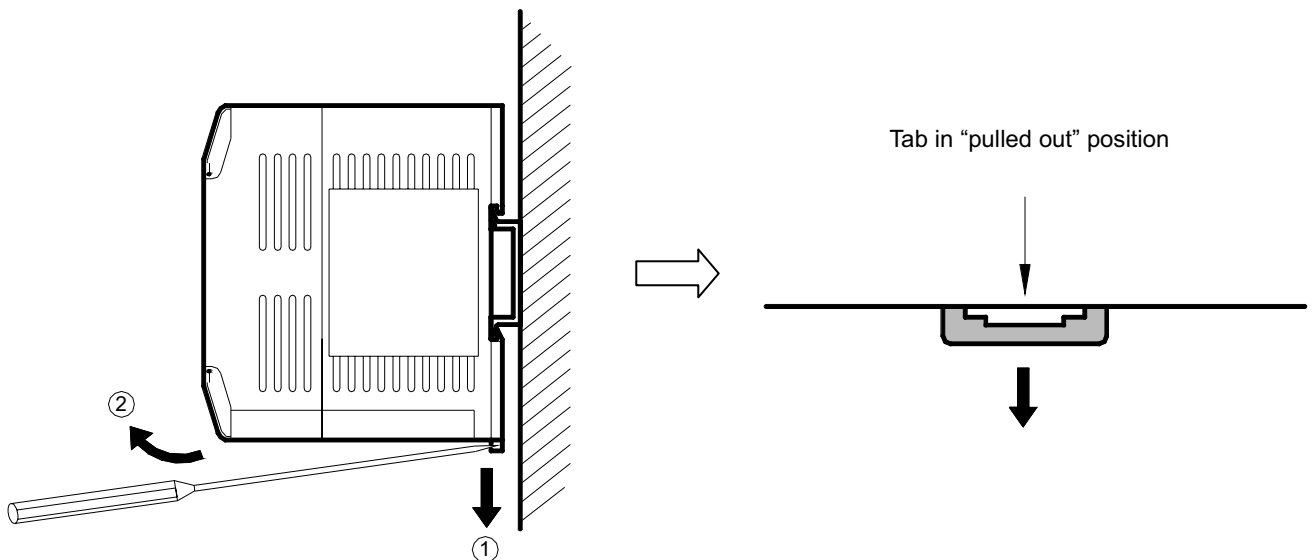

4.4 Fixation by Screws

In environments with larger vibration (more than 0.5G), the unit must be secured by M3 or M4 screws. Positions and sizes of screw holes in various models of FBs-PLC are illustrated in the following:

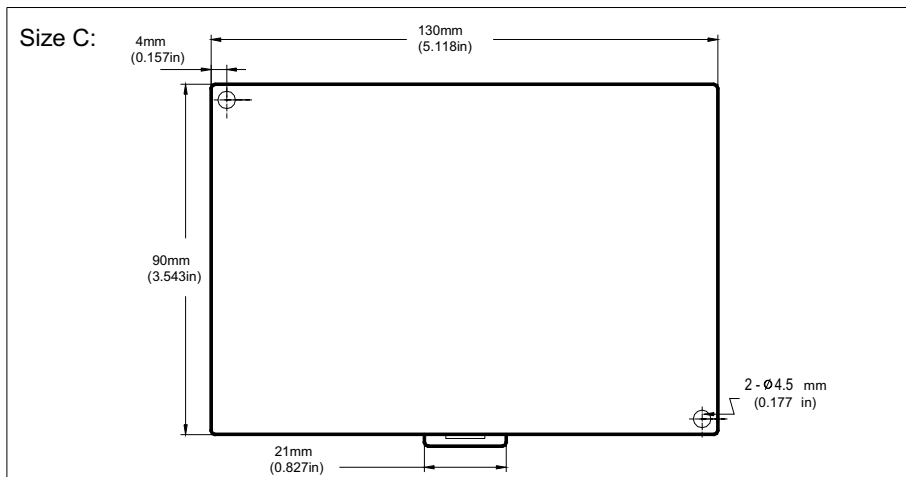
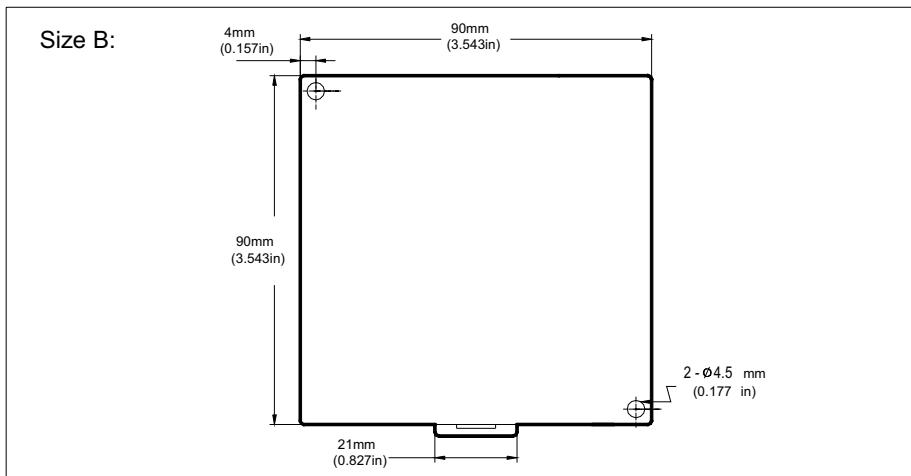
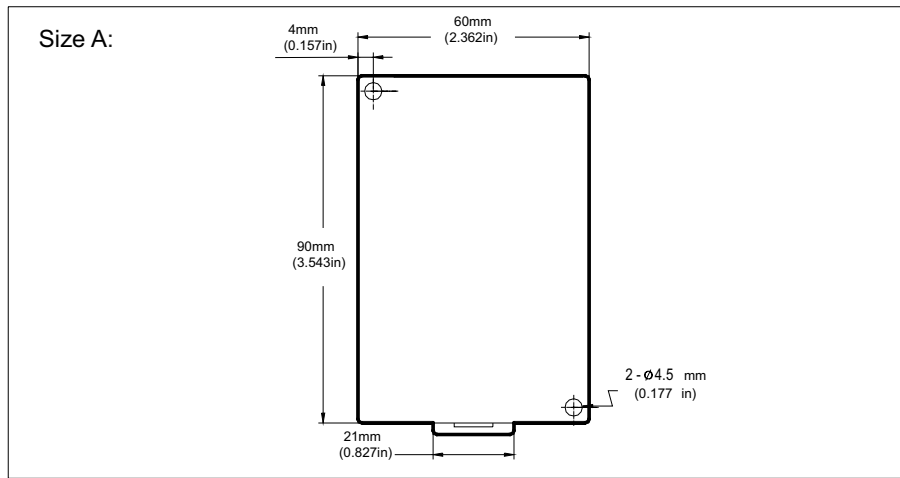

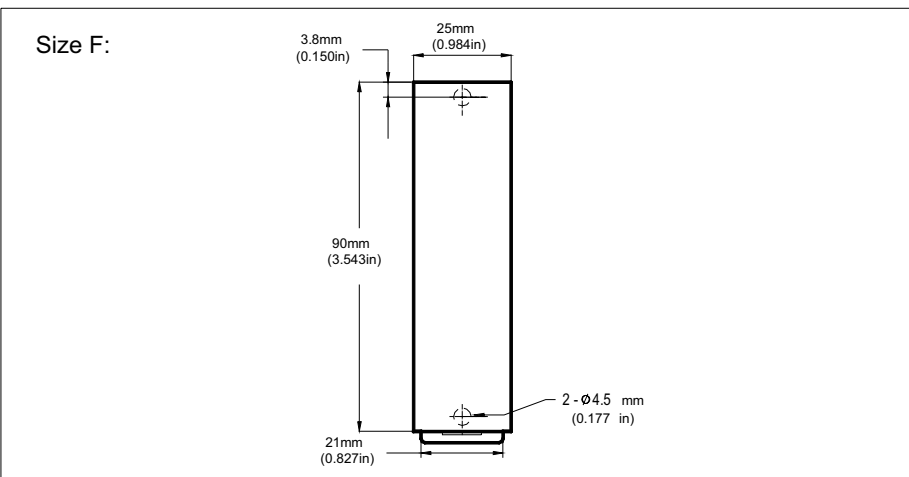
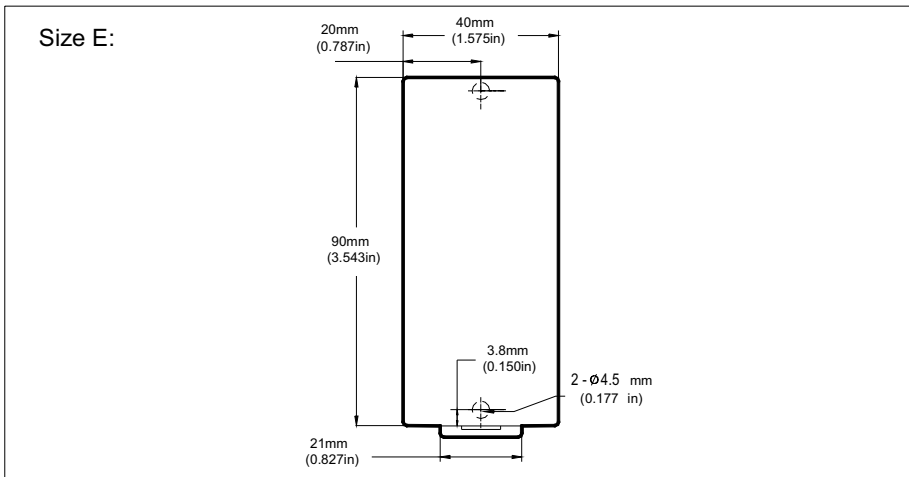
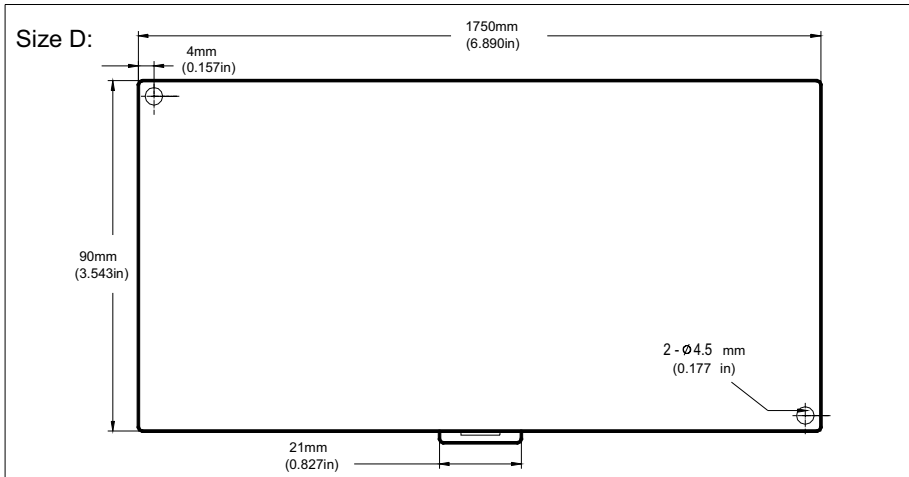

4.5 Precautions on Construction and Wiring

1. During the wiring of FBs-PLC, please follow local national standards or regulations for installation.
2. Please chose the wires with proper wire gauge for I/O wiring according to the current loads.
3. Shorter wires are preferred. It is advised that the length of I/O wiring does not exceed 100m (10m for high-speed input).
4. Input wiring should be separated from output or power wiring (at least 30~50mm apart). In case separation is not possible, adopt vertical crossing, no parallel wiring is allow.
5. The pitch of FBs-PLC terminal block is 7.62mm. The torque for screw and suggested terminal is shown below:

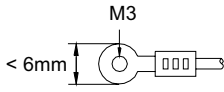
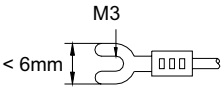
7.62 mm terminal block			torque: 6~8kg-cm
---------------------------	---	--	------------------

Chapter 5 Power Supply Wiring, Power Consumption Calculation, and Power Sequence Requirements

FBS-PLC internally has three kinds of circuit: a 5VDC logic circuit, a 24VDC output circuit, and a 24VDC input circuit. They are all powered by the built-in power supply of main/expansion units. Expansion modules other than main/expansion units do not contain any power supply and are powered by the power supply inside the main/expansion units or expansion power supply (FBS-EPOW). Main/expansion units or expansion power supply with their model numbers suffixed with “-D” means is operated by DC power source. Otherwise, AC power source is used.

 Note	
In industrial environments, main power may irregularly experience a surge current or high voltage pulse caused by the start or shut down of high power equipment. Users are advised to take necessary measures (for example, the use of isolation transformer or other MOV suppression devices) for the protection of PLC and its peripherals.	

5.1 Specifications of AC Power Sourced Power Supply and Wiring

The available AC power supplies of FBS-PLC are the 14 Watt (POW-16) supply for 10/14 PTs main unit, the 24 Watt (POW-24) supply for 20~60PTs main/expansion unit, and the 14 Watt expansion supply (FBS-EPOW) for expansion modules. Except that the FBS-EPOW is an independent module, POW-14 and POW-24 are to be installed on a main unit or inside an expansion unit, where their appearances are invisible. The following table lists the specifications:

Spec / Model		POW-14	POW-24	FBS-EPOW
Item	Voltage			
Input Range	Voltage	100 ~ 240VAC -15% / +10%		
	Frequency	50 / 60HZ -5% / +5%		
Max. Power Consumption		21W	36W	21W
Inrush Current		20A@264VAC		
Allowable Power Interrupt		20ms(min.)		
Fuse Spec.		1A , 250VAC		
Isolation Type		Transformer/Photo Couple Isolation, 1500VAC/minute		
Output Power*1	5VDC(logic circuit)	N/A*2	5V , ±5% , 1A(max)	5V , ±5% , 0.4A(max)
	24VDC(output circuit)	24V±10% , 200mA(max)*3	24V , ±10% , 400mA(max)	24V , ±1% , 250mA(max)
	24VDC(input circuit)	24V , ±10% , 400mA(max)	24V , ±10% , 400mA(max)	24V , ±10% , 250mA(max)

Note *1 : The 5VDC (for logic circuit) output power and the 24VDC (for output circuit) power can be accessed from the “I/O expansion output header” located on the right side of the main/expansion units for expansion modules. And the 5VDC power is also used by communication board (CBxx) or communication module (CMxx). The 24VDC power for input circuits is provided from the farthest 2 upper left terminals (labeled “+24V OUT-”) on the input terminal block of main/expansion unit to input circuit in expansion module or other sensors.

Note *2 : The 5VDC power of 10/14PTs main unit is generated from the 24VDC power in the output circuit, with specifications of 5VDC±10% and 400mA (max) (Circuit is located on the I/O board of 10/14PTs main unit).

Note *3 : Without any I/O expansion interface, the 24VDC power in 10/14PTs main unit is for its output circuit alone and cannot be used for other purposes.

 Note

The schematic diagram of AC power supply wiring in main/expansion units is shown below. Also be cautious about the following:

Please follow the wiring schemes regulated by local national standards to use single-pole switch (break hot wire “L”), or double-pole switch (break both “L” and “N”), to turn on or off the AC input power.

In wiring, hot wire “L” must be connected to the L terminal on unit, while the ground line “N” connected to the N terminal. Please use wires with diameters $1\text{mm}^2 \sim 2\text{mm}^2$.

All  terminals on main unit and expansion unit/module have to be connected to the EG (Earth Ground) terminal of main power system as shown in the figure below, with wire diameters larger than 2mm^2 .

 Warning

Output of power for sensor cannot be connected in parallel with other powers, in which the conflict between two sets of power will decrease their lifetime or cause immediate damage. This will induce unexpected malfunction of PLC and cause serious or even deadly damage to people or equipment.

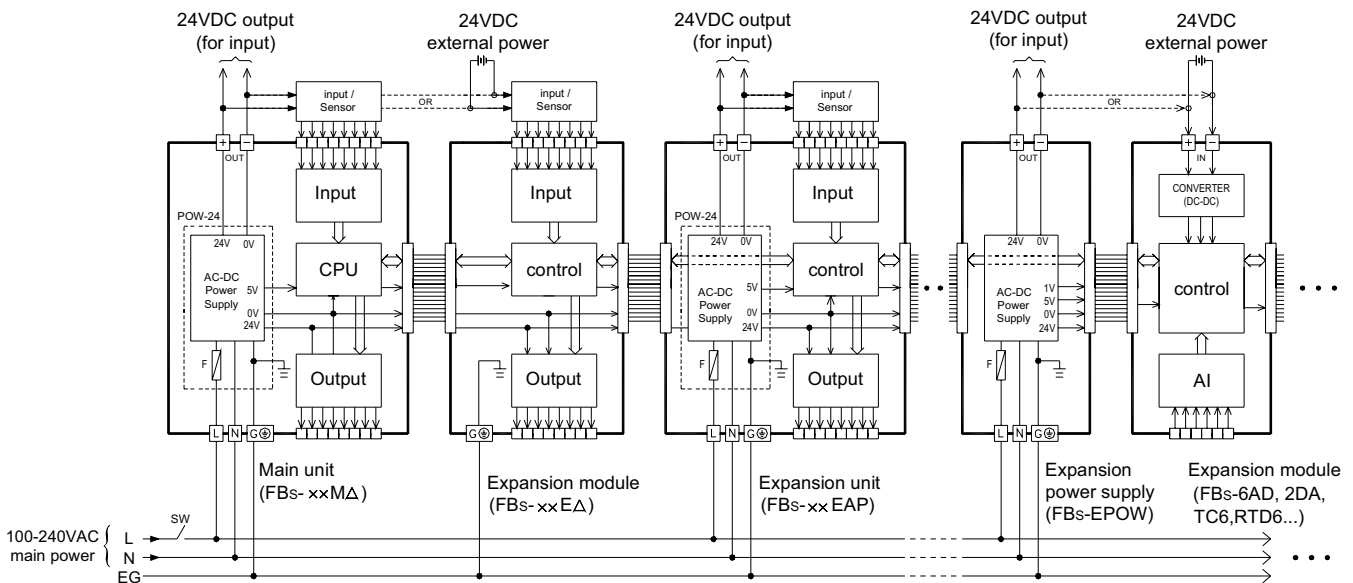

5.2 Specifications of DC Power Sourced Power Supply and Wiring

The available DC power sourced power supplies of FBs-PLC are the 10 Watt (POW-10-D) supply for 10/14PTs main unit, the 16 Watt (POW-16-D) supply for 20~60PTs main/expansion unit, and the 10 Watt expansion supply (FBs-EPOW-D) for expansion modules. The out power of DC source power supply is smaller than its AC counterpart because the power generated by the former only need to provide power to the 5VDC logic circuit and the 24VDC output circuit, while the power of 24VDC input circuit is derived directly by the 24VDC input power source through filter circuit. Besides the FBs-EPOW is an independent module, POW-14 and POW-24 are to be installed on a main unit or inside an expansion unit, where their appearances are invisible. The following table lists the specifications:

Spec. Item	Model	POW-10-D	POW-16-D	FBs-EPOW-D
	Rated Voltage		24VAC -15% / 20%	
Max. Power Consumption		15W	24W	15W
Inrush Current		20A@24VDC		
Allowable Power Interrupt		20ms(min.)		
Fuse Spec.		3A · 250VAC		
Isolation Type		Transformer/Photo Coupler Isolation, 500VDC/minute		
Power ^{*1} Output	5VDC(logic circuit)	N/A ^{*2}	5V, ±5%, 1A(max)	5V, ±5%, 0.4A(max)
	24VDC(output circuit)	24V±10%, 200mA(max) ^{*3}	24V, ±10%, 400mA(max)	24V, ±10%, 250mA(max)
	24VDC(input circuit)	Directly from input power, but limited by specifications of circuit and fuses, with capacity of 400mA(max.)		

Note ^{*1}: The 5VDC (for logic circuit) output power and the 24VDC (for output circuit) power can be accessed from the "I/O expansion output header" located on the right side of main/expansion units for expansion modules. The 24VDC power for input circuit is provided from the farthest 2 upper left terminals (labeled "+24V OUT-") on the input terminal block of main/expansion unit to input circuit in expansion module or other sensors.

Note ^{*2}: The 5VDC power of 10/14PTs main unit is generated by the oscillations of the 24VDC power in the output circuit, with specifications of 5VDC±10% and 400mA (max) (Circuit is located on the I/O board of 10/14PTs main unit)

Note ^{*3}: Without any I/O expansion interface, the 24VDC power in 10/14PTs main unit is for its output circuit alone and cannot be used for other purposes.

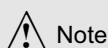

Note

The schematic diagram of DC power supply in main/expansion unit is shown below. Also be cautious about the following:

Please follow the wiring schemes regulated by local national standards to choose single-pole switch (break 24V+) or double-pole switch (break both 24V+ and 24V-) in order to turn on or off DC input power.

Wiring of 24V+ input power must be connected to the terminal labeled by +, while the 24V- end is connected to the - terminal, Please use wires with diameters of 1mm²~2mm².

The G terminals on main unit and all digital expansion units/modules must be connected to the EG (Earth Ground) terminal on main power system according to the scheme shown in the following figure, using wire diameters larger than 2mm².

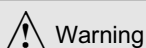

Warning

Output of 24VDC power for input circuit cannot be connected in parallel with other powers, in which the conflict between two sets of power will decrease their lifetime or cause immediate damage. This will induce unexpected malfunction of PLC and cause serious or even deadly damage to people or equipment.

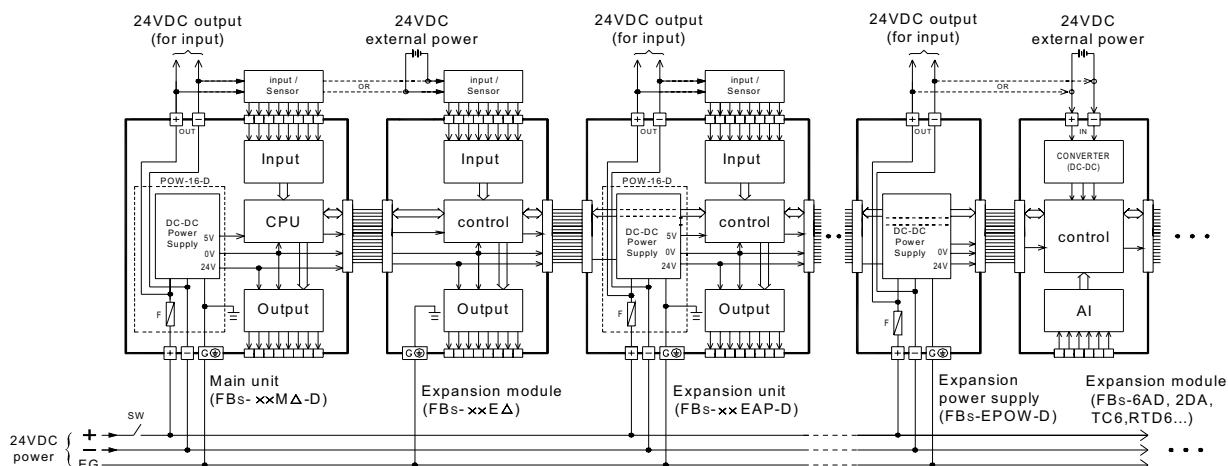

5.3 Residual Capacity of Main/Expansion Unit & Current Consumption of Expansion

Module

Besides its own circuits usage, the residual capacities of three sets of built-in power supply of main/expansion unit are big enough for other expansion modules usage. In addition, the expansion power (FBs-EPOW) module can also provides the power for expansion modules usage. As each model of the main/expansion unit has different residual capacity, various models of expansion modules also consume different amounts of current. In practice, one has to consider the match between the two to avoid overload in any of the three sets of output power. In the following, the worst case of the available residual capacity in each main/expansion unit and the maximum power consumption of expansion modules are described below spare.

5.3.1 Residual Capacity of Main/Expansion Unit

Model		Extra Capacity	Output Power		
			5VDC(logic circuit)	24VDC(output circuit)	24VDC(input circuit)
Main Unit	FBs-10/14MA-⊙		300mA	—	340mA
	FBs-20MA-⊙		753 mA	335mA	310mA
	FBs-24MA-⊙		722 mA	325mA	295mA
	FBs-32MA-⊙		712 mA	315mA	262mA
	FBs-40MA-⊙		688 mA	295mA	244mA
	FBs-60MA-⊙		644 mA	255mA	190mA
	FBs-10/14MC-⊙		300 mA	—	340mA
	FBs-20MC-⊙		753 mA	335mA	310mA
	FBs-24MC-⊙		722 mA	325mA	295mA
	FBs-32MC-⊙		712 mA	315mA	262mA
	FBs-40MC-⊙		688 mA	295mA	244mA
	FBs-60MC-⊙		644 mA	255mA	190mA
	FBs-20MN-⊙		710mA	310mA	325 mA*
	FBs-32MN-⊙		670mA	297mA	280 mA*
	FBs-44MN-⊙		627 mA	276 mA	250 mA*
Expansion Unit	FBs-24EAP-⊙		948 mA	350mA	337mA
	FBs-40EAP-⊙		918 mA	320mA	292mA
	FBs-60EAP-⊙		880 mA	280mA	238mA

* except differential inputs (X0,1,4,5,8,9,12,13)

- Suffixed code—⊙ : hollow means AC power, — D DC power.
- In the above table, the residual capacity is calculated according to the most power-consuming model (for example, MCT) of in each main/expansion unit by its I/O point number, under the maximum load condition (with both DI and DO ON). The basic units for calculation are 7.5mA/PT for high/medium speed DI, 4.5mA/PT for low speed DI (Ultra high speed DI does not use the 24VDC power in input circuit), 10mA/PT for high speed DO, 7.5mA/PT for medium speed DO, and 5mA for low speed DO and relay output. (excluding the SSR model).
- See Sections 5.1 and 5.2 for the residual capacity of expansion power (-EPOW and -EPOW-D)

Warning

Either for the built-in power supply of the main/expansion unit or the expansion power supply for the expansion unit, the total amount of current cannot exceed the value listed in the above table. Any violation will cause a voltage drop by overloading the power supply, or intermittent powered with the supply in protection mode, either of which will result in unexpected action of PLC and cause harm to people or damage to equipment.

5.3.2 Maximum Current Consumption of Expansion Module

Without its own power supply, expansion modules must be supported by the main/expansion unit, expansion power, or external power supply (24VDC input circuit alone). The following table lists the maximum consumption current of each expansion module.

Model		Current	5VDC Logic Circuit	24VDC Output Circuit	24VDC Input Circuit
Digital I/O Expansion Module	FBs-24EA		52 mA	50mA	63mA
	FBs-40EA		82 mA	80mA	108mA
	FBs-60EA		120 mA	120mA	162mA
	FBs-8EA		30 mA	20mA	18mA
	FBs-8EX		30 mA	—	36mA
	FBs-8EY		27 mA	40mA	—
	FBs-16EA		40 mA	40mA	36mA
	FBs-16EY		39 mA	80mA	—
	FBs-20EX		46 mA	—	90mA
	FBs-24EX		48 mA	—	108mA
	FBs-24EYT		66 mA	—	—
Numeric I/O Expansion Module	FBs-32DGI		14 mA	—	36mA
	FBs-7SG1		14 mA	—	200 mA
	FBs-7SG2		14 mA	—	410 mA
	FBs-6AD		30 mA	—	45 mA
	FBs-2DA		18 mA	—	70 mA
	FBs-4DA		30 mA	—	130 mA
	FBs-4A2D		30 mA	—	80 mA
	FBs-TC2/TC6		32 mA	—	30 mA
	FBs-RTD6		32 mA	—	30 mA
	FBs-TC16		33 mA	—	30 mA
	FBs-RTD16		32 mA	—	30 mA
Communication Board (CB)	FBs-CB2		13 mA	—	—
	FBs-CB22		25 mA	—	—
	FBs-CB5		55 mA	—	—
	FBs-CB55		100 mA	—	—
	FBs-CB25		60 mA	—	—
Communication Module (CM)	FBs-CM22		18 mA	—	—
	FBs-CM55		100 mA	—	—
	FBs-CM25		67 mA	—	—
	FBs-CM25E		110 mA	—	—
	FBs-CM55E		120 mA	—	—
	FBs-CM25C		—	—	20 mA
	FBs-CM5R		—	—	20 mA
	FBs-CM5H		—	—	76 mA
Others	FBs-DAPB		—	—	51 mA
	FBs-DAPC		—	—	—
	FP-07C		—	—	—

- The above table lists the required current for the maximum consumption in each expansion module. The 24VDC input circuit consumes 4.5mA less per point of OFF state DI in DI/O module, while the 24VDC output circuit consumes 5mA less per point of OFF state DO. The effect of power consumption variation regarding the ON/OFF state of DI/DO of expansion modules other than DI/O are less significant and can be neglected.
- The effect of residual capacity variation regarding the ON/OFF state of DI/DO for 5VDC logic circuit can be neglected.

5.4 Requirement of Power Sequence in Main Unit & Expansion Unit/Module

When the power is on, the FBs-PLC main unit first detects the type and number of expansion unit/module attached to its expansion interface and get the actual I/O configuration. Therefore, while the main unit performs detection, the power in expansion unit/module should be already UP, otherwise, the detected I/O configuration will not correct. Namely, the power of expansion unit/module should be ON simultaneously or even earlier. There will be no time sequence error when main unit/expansion unit/module are connected together to one power. If the expansion unit and main unit powered by different powers (or the same power but different switches), or external power supply is used for expansion modules, time sequence of both powers should be considered. To solve the problem of the expansion unit/module power not get ready before main unit power does, FBs-PLC provides a special R4150 register which can delay the detection time of I/O configuration. The time base of R4150 is 0.01sec with a default value of 100 (namely a 1sec delay), which can be set from 100~500 (1~5sec), as shown in the figure below. If the expansion unit power cannot be UP within 1sec after main unit power is ON, the R4150 time needs to be set longer to delay the detection by CPU. It cannot exceed 5sec, however, otherwise the configuration of expansion interface cannot be detected.

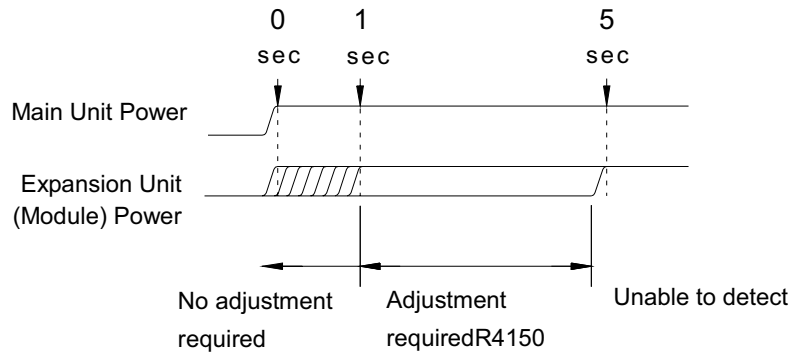

Chapter 6 Digital Input (DI) Circuit

The FBS-PLC provides the ultra high speed differential double end 5VDC inputs (i.e., single input with two terminals without common) and the single-end 24VDC inputs which use the common terminal to save terminals. The response speeds of single-end common input circuits are available in high, medium and low. Because the double end input circuit has two independent terminals, it can be connected either in SINK or SOURCE (we will use the term SRCE) for input or in differential input wiring for line driver source. The single-end input circuit can be set to SINK or SRCE type by varying the wiring of the common terminals S/S inside PLC and external common wire of input circuits (see Sec. 6.3 for details).

6.1 Specifications of Digital Input (DI) Circuit

Item		5VDC Differential Input	24VDC Single-end Input				Note
		Ultra High Speed(HSC) 920KHz	High Speed(HSC) 100KHz	Medium Speed(HSC) 20KHz*1	Mid/Low Speed 470 μS*2	Low Speed (200Hz)	
Input Signal Voltage		5VDC±10%	24VDC±10%				
Input Current Threshold	ON Current	> 6 mA	> 4mA		> 2.3mA		
	OFF Current	< 2 mA	< 1.5mA		< 0.9mA		
Maximum Input current		20mA	7mA		4.2 mA		
Input Status Indication		Displayed by LED: Lit when "ON", dark when "OFF"					
Isolation Type		Photo coupler signal isolation					
SINK/SRCE Wiring		Independent Wiring		Via variation of internal common terminal S/S and external common wiring			
List of Input Response Speed for Various Models	FBs-20MN	X0,1		X2~11			*1 : Limit of input speed in MA model is 10KHz
	FBs-32MN	X0,1,4,5		X2,X3,X6~15	X16~19		
	FBs-44MN	X0,1,4,5,8,9,12,13		X2,3,6,7,10,11,14,15	X16~27		
	FBs-10MC		X0,1	X2~5			
	FBs-14MC		X0,1	X2~7			
	FBs-20MC		X0,1	X2~11			
	FBs-24MC		X0,1	X2~13			
	FBs-32MC		X0,1	X2~15	X16~19		
	FBs-40MC		X0,1	X2~15	X16~23		
	FBs-60MC		X0,1	X2~15	X16~35		
	FBs-10MA			X0~3	X4~5		
	FBs-14MA			X0~3	X4~7		
	FBs-20MA			X0~3	X4~11		
	FBs-24MA			X0~3	X4~13		
	FBs-32MA			X0~3	X4~19		
	FBs-40MA			X0~3	X4~23		
	FBs-60MA			X0~3	X4~35		
Expansion Unit/Module					All Input Points		
Noise Filtering Time Constant*3		DHF(0ns ~ 15ms) + AHF(470ns)		DHF(0 ~ 15ms) + AHF(470 μs)		AHF(4.7ms)	DHF : Digital Hardware Filter AHF : Analog Hardware Filter

* : The standard product of MC-type High-Speed input is 2 points, it can extend to 3~8points (Option). Every increment one High-speed input point, and decrement one Middle-speed input point relatively. Only X4~X5,X8~X9 and X12~X13 input can be extended, and the priority is low serial-number to High serial-number.

6.2 Structure and Wiring of 5VDC Ultra High Speed Differential Input Circuit

Only the MN main unit of FBs provides the 5VDC ultra high speed differential input circuit, which is mainly used for the input of hardware high speed counter (HHSC) with a maximum working frequency up to 920 KHz. In practice, to ensure the high speed and high noise immunity, please use Line-Driver for differential line driving. In environments with small noise and medium working frequency ($< 100\text{KHz}$), however, it can be changed to the 5VDC single-end SINK or SRCE input or to the 24VDC single-end SINK or SRCE input by connecting a $3\text{K}\Omega/0.5\text{W}$ resistor in series, as shown in the figure below.

- (A) Wiring of 5VDC differential input for Line-Driver driving (with frequency up to 920KHz for high speed and environments with large noise)

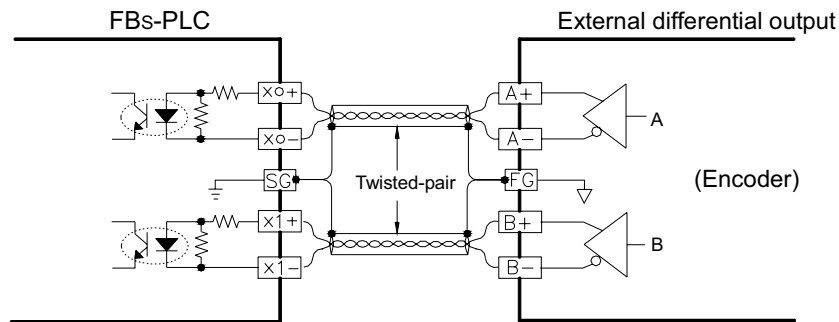

- (B) Wiring of 5VDC differential input to 5VDC single SINK or SRCE input (100KHz)

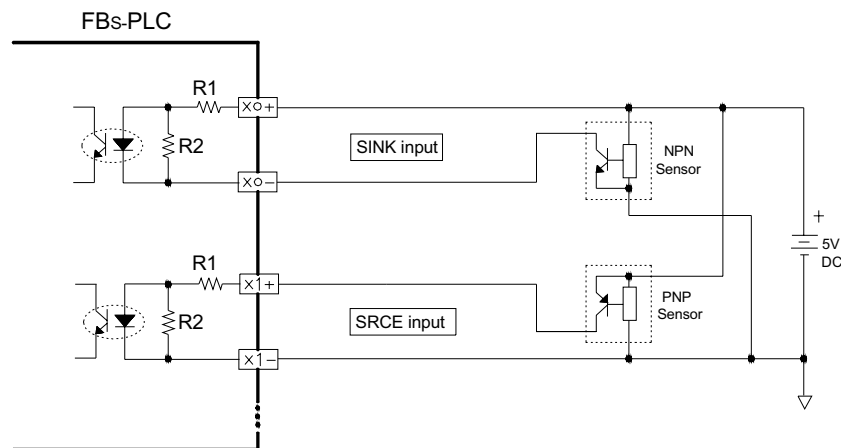

- (C) Method of converting 5VDC differential input to 24VDC single-end SRCE input (frequency $< 100\text{KHz}$)

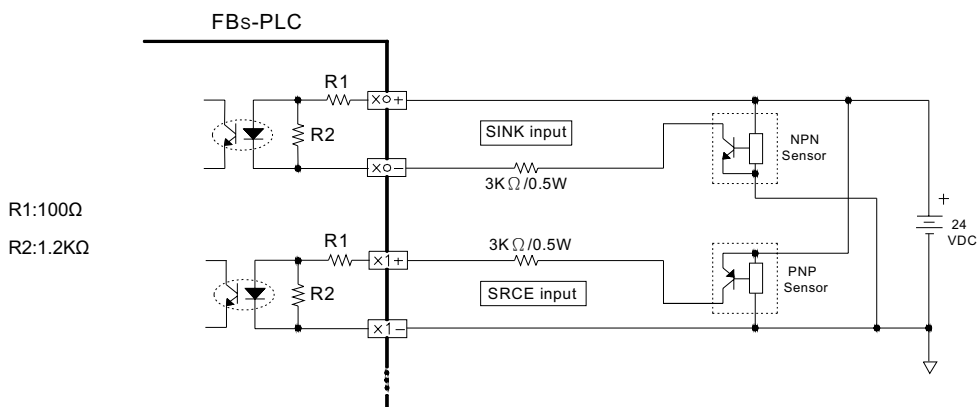

6.3 24VDC Single-End Input Circuit and Wiring for SINK/SRCE input

The 24VDC single-end digital input circuits of FBS-PLC are available for high, medium and low speed. They all have the similar circuit structures but with different response speeds. To save input terminals, the circuit of single-end input is implemented by connecting one end of all input points (photo coupler) inside the PLC to the same internal common point labeled as S/S. The other end of each input circuit is connected to corresponding terminals such as X0, X1, X2, etc. The S/S common terminal and N single-end inputs comprise of N digital inputs (i.e., only N+1 terminals are used for N terminals). Therefore, we call this type of input structure the single-end input. The user also needs to do the same thing when making the connection of external digital input devices. Namely, the one end of all input devices (e.g., buttons, switches) are connected together and called the external common wire, while the other ends of input circuits are connected to the input terminals X0, X1, X2, etc., of PLC. Then finish it by connecting the external common wiring and internal common terminal S/S to the positive/negative terminals of the 24VDC power. When connect the internal common terminal S/S to 24V+ (positive) and the external common wire to 24V- (negative), then the circuit serve as SINK input. On the contrary, while exchange the wiring of the above internal and external common will serve as a SRCE input. The above wiring schemes can illustrated below:

- Wiring of single-end common SINK input (internal common terminal S/S → 24V+, external common wiring → 24V-)

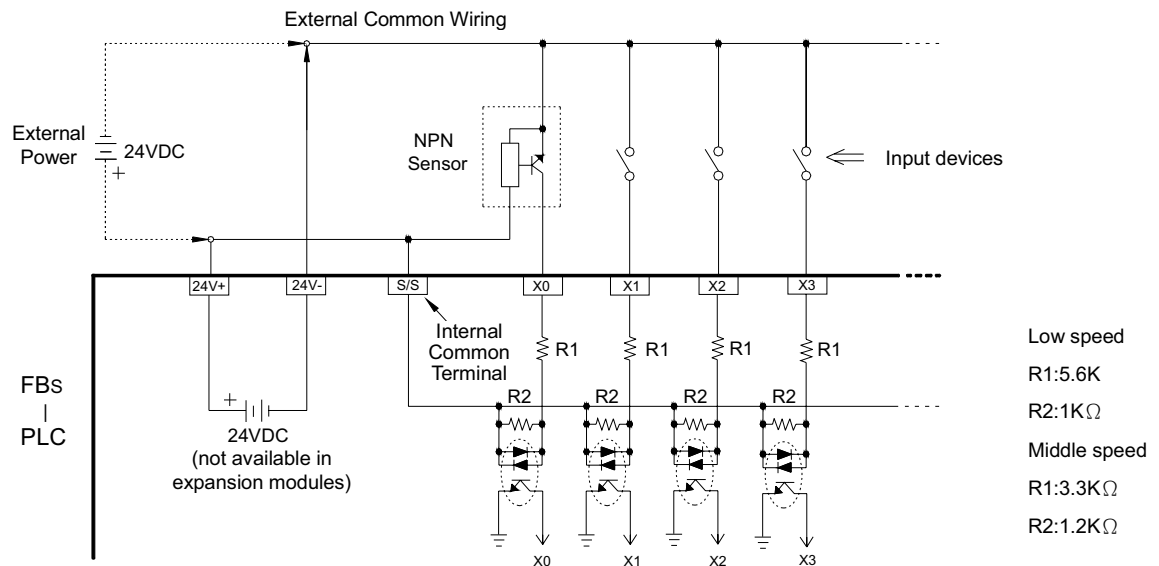

- Wiring of single-end common SRCE input (internal common terminal S/S → 24V-, external common wiring → 24V+)

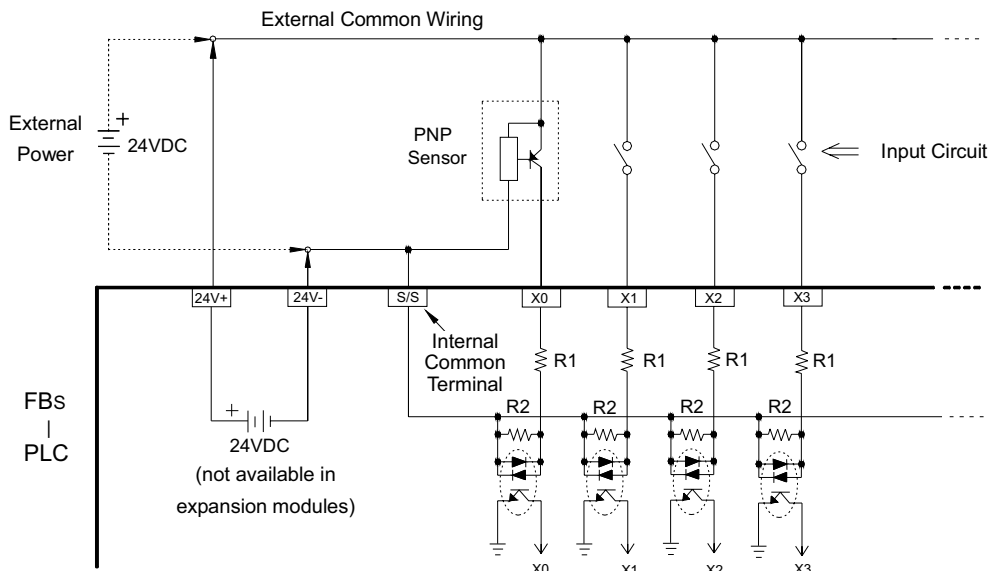

Chapter 7 Digital Output (DO) Circuit

The digital outputs of FBs-PLC are available in the following two structures: the 5VDC ultra high speed Line-driver type differential output (i.e., one output occupying two terminals), and the single-end output circuit for saving terminals. There are three kinds of output device for the single-end output, which are relays, TRIAC and transistors. Since the relay and TRIAC are bilateral, even when used in single-end output, they can serve as SINK or SRCE output. The transistor, however, because of its polarities, after being used as single-end common output, its SINK and SRCE polarities are exactly the opposite (common point Cn of SINK output must connect to negative end of DC power). Therefore, the product model of transistor output of FBs-PLC for SINK and SRCE is distinct. At the right side of terminal block of FBs-PLC, there is a place for making SINK or SRCE label. The following are labeling examples of: ① SINK output models in FBs-PLC ② Transistor SRCE output model ③ Relay of TRIAC models with no SINK /SRCES polarity :

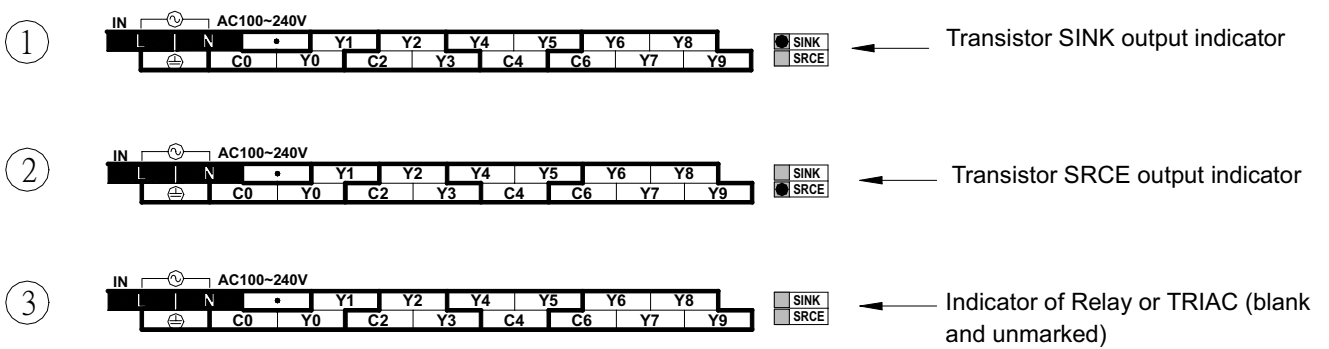

Warning

No over current protection is available in the FBs series PLC. Except for the 5V differential output circuit, all other output circuits have to be added with over current or short circuit protections externally, such as fuses, in applications with safety concern.

Terminals labeled by “●” on the terminal block are empty contacts, which cannot be connected with any wire to maintain the required safety clearance and to avoid damage to the unit.

In situations where simultaneous operations of outputs(such as reverse/forward action of motor) pose safety concerns, besides the interlock in PLC programs, additional interlock circuits are needed outside PLC, as shown below :

The diagram illustrates an interlocking circuit for two magnetic switches, Relay A and Relay B. The PLC Forward output is connected to the coil of Relay A. The PLC Reverse output is connected to the coil of Relay B. A Forward Limit switch is connected in series with the Forward output. A Reverse Limit switch is connected in series with the Reverse output. Interlocking is achieved by connecting the normally closed (NC) contact of Relay A in series with the coil of Relay B, and the NC contact of Relay B in series with the coil of Relay A. This ensures that both relays cannot be energized simultaneously.

7.1 Specifications of Digital Output Circuit

Item		Differential Output	Single-End Transistor Output			Single-End Relay Output	Single-End TRIAC Output	
		Ultra High Speed	High Speed	Medium Speed	Low Speed			
Maximum switching (working) Frequency		920KHz(1-phase) 460KHz(2-phase)	100KHz	20KHz	200HZ	For ON/OFF, not for frequent exchange		
Working Voltage		5VDC±10%	5~30VDC			<250VAC,30VDC	100~240VAC	
Maximum Load Current	Resistive	50mA	0.5A	0.1A	0.5A	2A/single, 4A/common	1A	
	Inductive					80VA	15VA/100VAC 30VA/200VAC	
Maximum Voltage Drop (@ maximum load)		—	0.6V	2.2V	1.2V	0.06V(initial)	1.2Vrms	
Minimum Load		—	—			2mA/DC power	25mA	
Leakage Current		—	< 0.1 mA/30VDC			—	2mA	
Maximum Output Delay Time	ON→OFF	200nS	200nS	15 μ S	1mS	10mS	1mS	
	OFF→ON			30 μ S			1/2AC period	
Output Status Indication		LED is bit when "ON", dark when "OFF"						
Over Current Protection		N/A						
Isolation Type		Photo Coupler Isolation				Electromagnetic Isolation	Photo Coupler Isolation	
SINK/SRCE Output Type		Independent Dual Terminals for arbitrary connection	Choose SINK/SRCE by models and non-exchangeable			Bilateral device, can be arbitrarily set to SINK/SRCE output		
List of Input Response Speed for Various Models	FBs-20MN(T,S)	Y0~1		Y2~7		Y2~7	Y2~7	
	FBs-32MN(T,S)	Y0~3		Y4~7	Y8~11	Y4~11	Y4~11	
	FBs-44MN(T,S)	Y0~7			Y8~15	Y8~15	Y8~15	
	FBs-10MC(T,S)		Y0,2	Y1,3		All output points	All output points	
	FBs-14MC(T,S)		Y0,2	Y1,3~5				
	FBs-20MC(T,S)		Y0,2	Y1,3~7				
	FBs-24MC(T,S)		Y0,2	Y1,3~7	Y8~9			
	FBs-32MC(T,S)		Y0,2	Y1,3~7	Y8~11			
	FBs-40MC(T,S)		Y0,2	Y1,3~7	Y8~15			
	FBs-60MC(T,S)		Y0,2	Y1,3~7	Y8~23			
	FBs-10MA(T,S)			Y0~3				
	FBs-14MA(T,S)			Y0~3	Y4~5			
	FBs-20MA(T,S)			Y0~3	Y4~7			
	FBs-24MA(T,S)			Y0~3	Y4~9			
	FBs-32MA(T,S)			Y0~3	Y4~11			
	FBs-40MA(T,S)			Y0~3	Y4~15			
	FBs-60MA(T,S)			Y0~3	Y4~23			
	Expansion Units/Modules(T,S)				All output points			

* : The standard product of MC-type High-Speed output is 2 points, it can extend to 3~8points (Option). Every increment one High-speed output point, and decrement one Middle-speed output point relatively. Only X4~X5,X8~X9 and X12~X13 output can be extended, and the priority is low serial-number to High serial-number.

7.2 5VDC Ultra High Speed Line-Driver Differential Output Circuit and its Wiring

The 5VDC ultra high speed Line-Driver differential output circuit of FBS-PLC is only available for the main unit of the MN model. Its output can connect to general photo coupler circuit or Line-Receiver input circuit, with the connection shown in the figure below. To improve noise immunity and maintain signal quality, please use twisted pair with shield (or aluminum foils) for connection and connect the shield with SG of PLC and FG of the driver. Please also operate in 2-phase driving mode (because 2-phase driving can automatically cancel interferences from noise pulses).

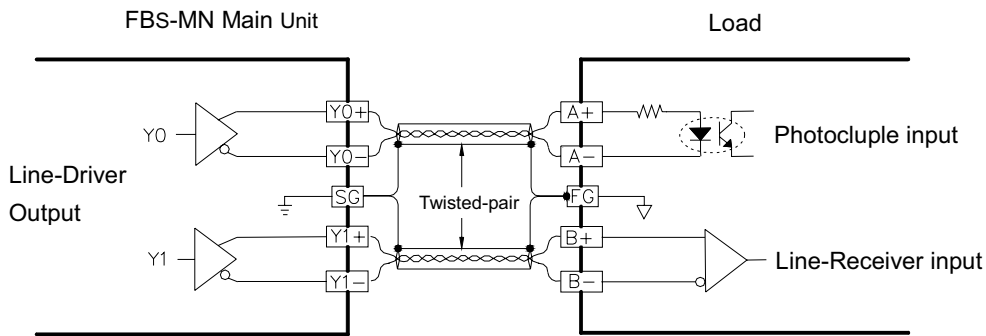

(With frequency up to 750KHz, for use in high speed and large noise environments)

7.3 Single-End Output Circuit

Except that the 5VDC ultra high speed output circuit has independent dual terminal outputs, all other output circuits such as relays, transistors or TRIAC are single-end output structure. A single-end output in each digital output (DO) takes up only one terminal. But since any output device has two ends, the one end of several output devices have to be connected together to one common point (called output common) for single-end output. Then each output point can output via this common point. The more output device share a same common points, the more terminals are saved, while relatively increasing the current running through the common point. Combination of any output common with its individual single-end outputs are called a Common Output Block, which is available in 2, 4 and 8PTs (high-density module) in FBS-PLC. Each Common Output Block is separated from one another. The common terminal has a label initiated with letter "C", while its numbering is determined by the minimum Yn number which comprise the output block. In the example of the figure below, the number of common terminal of output block Y2 and Y3 is C2, while the number of common terminal of output Block Y4, Y5, Y6 and Y7 is C4. The various single-end common output circuits are described below :

7.3.1 Structure and Wiring of Single-End Relay Output Circuit

Because relay contacts have no polarity, it can be applied for AC or DC load power. Each relay can provide current up to 2A. The maximum rated current in all output commons of FBS-PLC is 4A. Its mechanical lifetime can reach up to 2 million times, while the contacts have a shorter lifetime. The lifetime also varies depending on working voltage, load type (power factor $\cos \phi$) and contact current. The relation between them is plotted in the figure below. In the case of pure resistive load ($\cos \phi = 1.0$) at 120VAC and 2A, the lifetime of contacts is about 250 thousand times. While for high inductive or capacitive load with $\cos \phi$ up to 0.2 and current within 1A, the lifetime decreases rapidly to about 50 thousand times (AC200V) or 80 thousand times (AC120V).

FBS-PLC

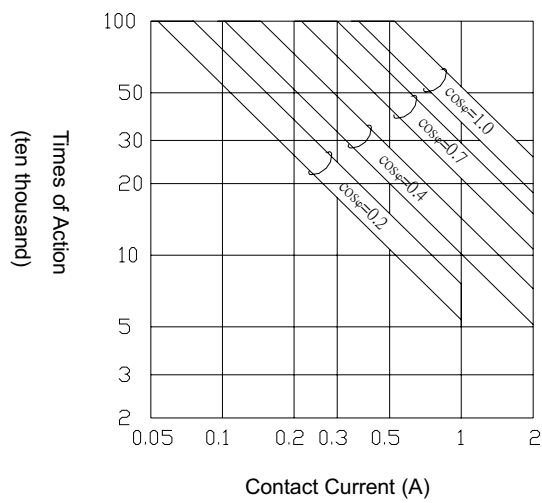
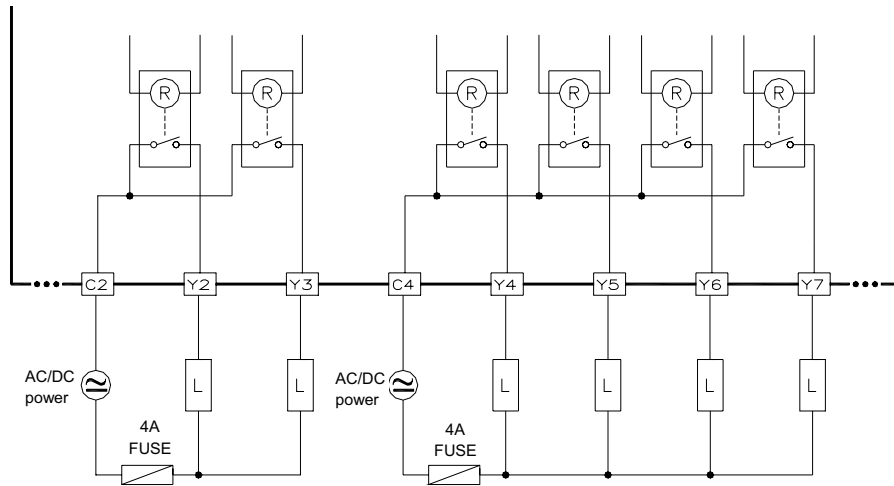

7.3.2 Structure and Wiring of Single-End Transistor SINK and SRCE Output Circuit

A. Transistor Single-End SINK Output

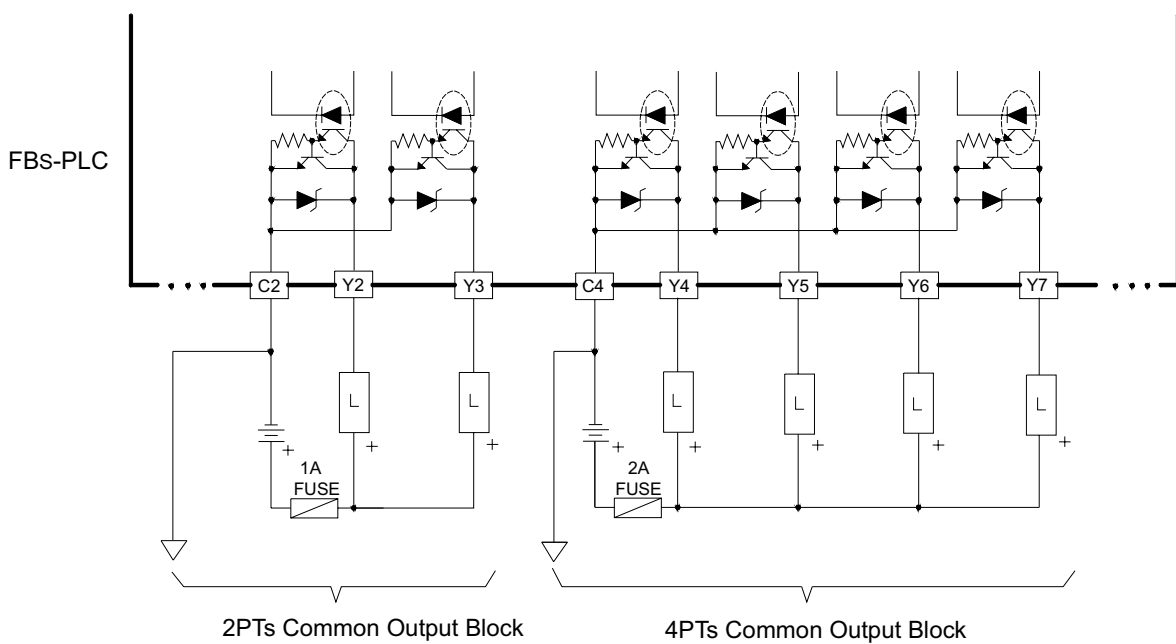

B. Transistor Single-End SRCE Output

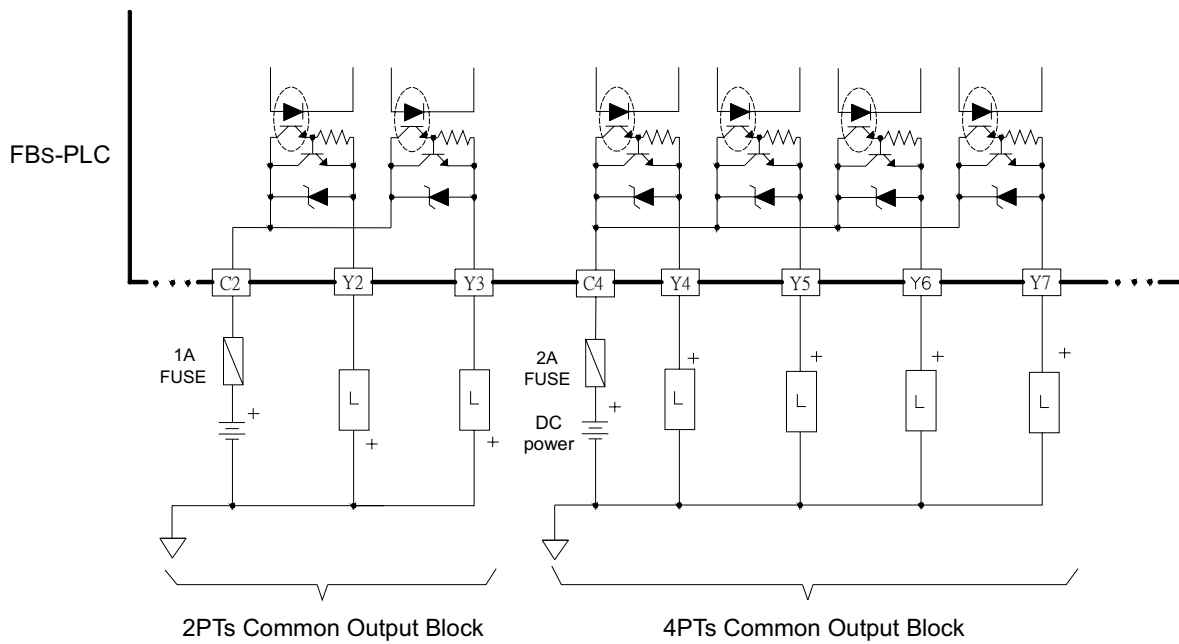

The figure above uses output blocks of 2PTs common and 4PTs common as an example to explain the differences in structural and wiring for SINK and SRCE output circuits, respectively. (8PTs common has the same block structure and wiring, except with different point number) The single-end SINK output and SRCE transistor output in FBS-PLC are different models. The user must check whether it is SINK output model or SRCE output model when purchasing.

7.3.3 Structure and Wiring of Single-End TRIAC Output Circuit

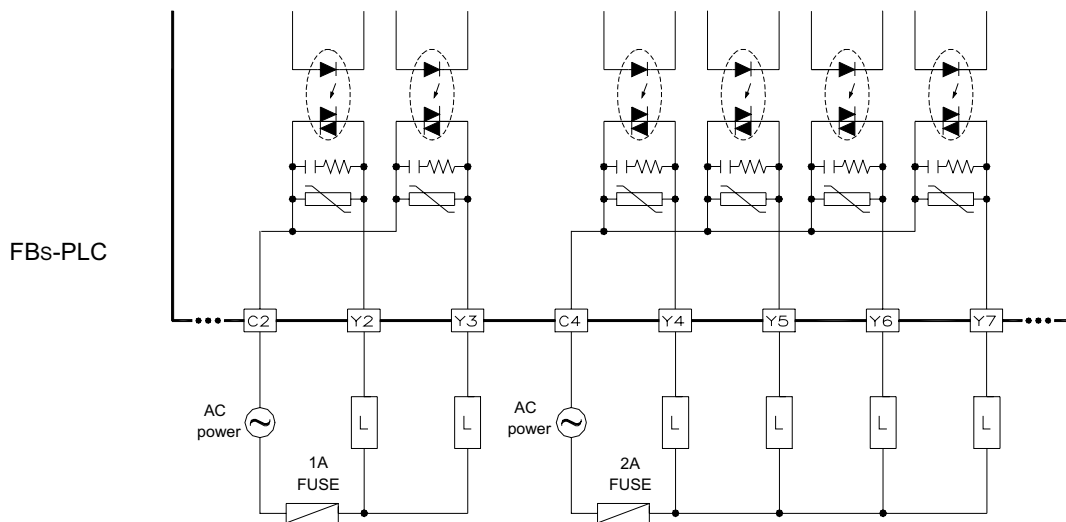

- TRIAC output can only be used for AC load. Furthermore, a load current larger than the holding current (25mA) is required to keep TRIAC conducting. Therefore, when the load current is less than 25mA, a Dummy load must be connected parallel with load to make the load current larger than the TRIAC holding current. Besides, note that even when TRIAC output is open (OFF), there still exists a leakage current of 1mA (AC100V) or 2mA (AC200V), which may trigger actions in loads that can be activated by small currents. Connection of Dummy load in parallel with the load described above can solve this problem.

7.4 Speed up the Single-End Transistor Output Circuit (only applicable to high- and medium-speed)

Either with the SINK or SRCE structure in single-end output transistor circuit, when the transistor switches from ON to OFF, the junction capacitor between transistor CE electrodes should be charged to near the load voltage VDD before it can stop the current running through the photocoupler inside the load, which increase the OFF time and decrease the response speed. This problem can be solved by adding a Dummy load to accelerate charging rate and speed up the working frequency of transistor output. For the transistor output in FBs-PLC, Dummy load that are added to the high- and medium-speed transistor output and generate a load current of 20~50mA is adequate. For low speed transistor where its driving capability (0.5A) but speed is concerned, adding a Dummy load only decreases its driving capability without any significant improvement and hence is not recommended. The following diagram shows how to add a Dummy load to SINK and SRCE transistor output.

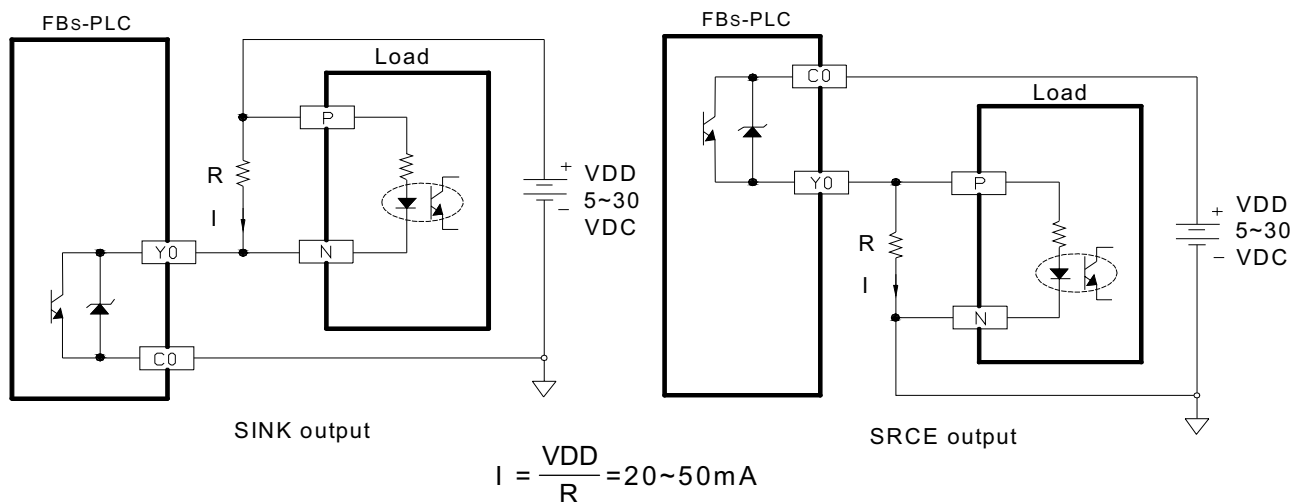

7.5 Output Device Protection and Noise Suppression in DO Circuit

Since the digital output circuits are mainly used for the ON/OFF switching operation, the output components such as relays, transistors and TRIAC can be deemed as kinds of switch components. Normally, surge currents or counter-electromotive force voltages are generated during the ON/OFF operation of these switch components. The effect of surge currents or counter-electromotive force voltages is particularly serious when heavy capacitive or inductive loads are incorporated, which may cause damage to the output components or generate noises in other electronic circuits and equipment. Among those three FBs-PLC output components, where TRIAC require no special treatment because of their features of smaller rated current, zero cross in ON/OFF, and built-in protection circuits, special consideration should be given to relays and transistors when they are used in high power applications or connected with capacitive or inductive loads and are described in the following:

7.5.1 Protection of Relay Contacts and Noise Suppression

Because the relay contacts are used to contact switch components having extremely low resistance, the surge current IR generated instantly upon turning on the relay is normally pretty strong (even if the steady load current is very small). Under such strong surge, the contact tends to melt and stick due to extreme temperature in such a way that the relay cannot trip when it is disconnected. In addition, when the relay connections are OFF, large di/dt is generated because of the instantaneous change from low resistance to open circuit (∞) soon after following the tripping of contact. As a result, an extremely strong counter-electromotive force voltage is induced, which creates sparks between the electrodes of two relay contacts and results in poor contact due to carbon deposits. Among those three output components, either in ON or OFF state, very serious interference can be caused by the surge current or the counter-electromotive of the relay. The solutions to this problem are listed as follows:

A. Suppression of Surge Current \Rightarrow Connect a small resistor R in series to lower the surge current, but note that too large R will affect the driving capability or cause too much voltage drop.

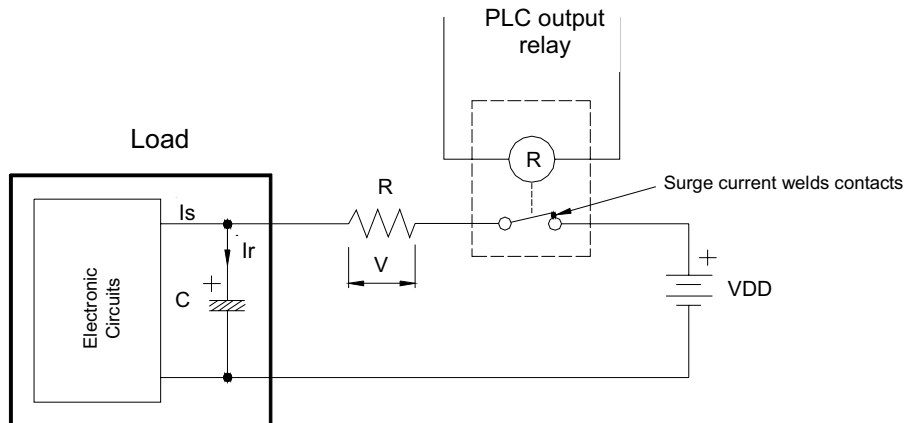

$$R \geq \frac{VDD}{I_r \text{ max}} \quad (\text{note power dissipation } P = I_s^2 R \text{ and voltage drop } V = I_s R)$$

$I_r \text{ max of relay in FBS-PLC} = 5A$

B. Suppression of Counter-Electromotive Force

For the inductive load, whether in AC or DC power, suppression devices must be connected in parallel to both its ends to protect the relay contacts and lower noise interference. The schematic diagrams for AC and DC powers are shown below, respectively:

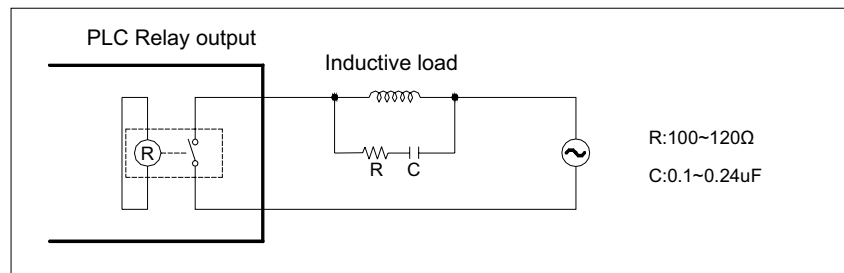

Scheme of AC power load

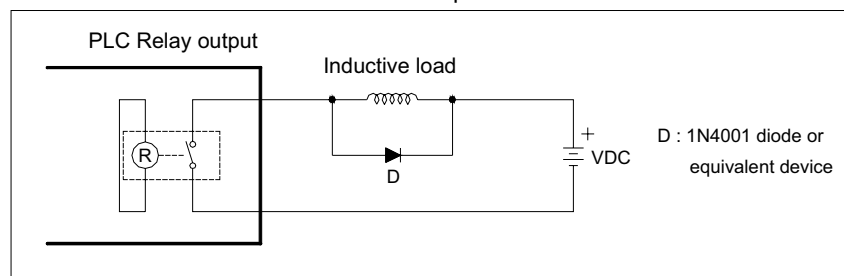

Suppress by a diode in DC power load (for low power)

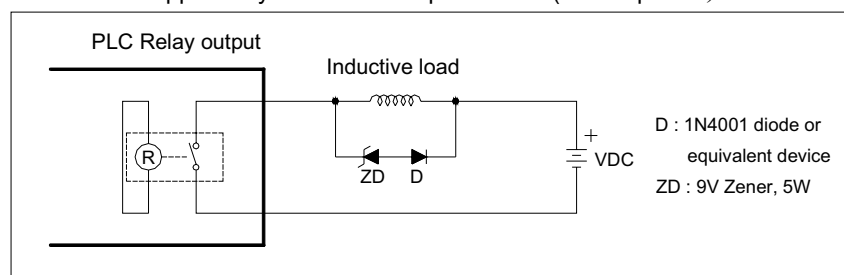

Suppress by a diode + Zener in DC power load (for high power and frequent ON/OFF)

7.5.2 Protection of Transistor Output and Noise Suppression

The transistor output in FBs-PLC already includes Zener diode for counter-electromotive force, which is sufficient for low power inductive load and medium frequency of ON/OFF application. In conditions of high power or frequent ON/OFF, please construct another suppression circuit to lower noise interference and prevent voltage from exceeding the limit or overheating that may damage the transistor output circuit.

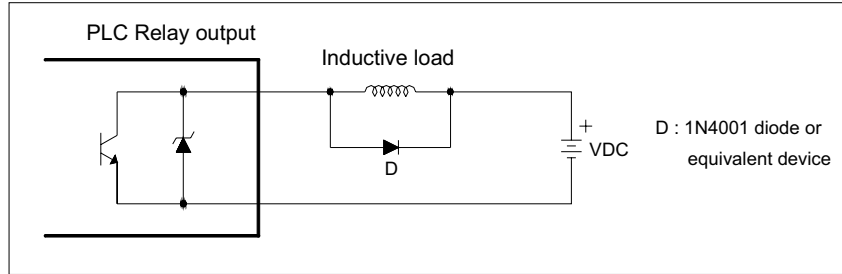

Suppress by a diode (for low power)

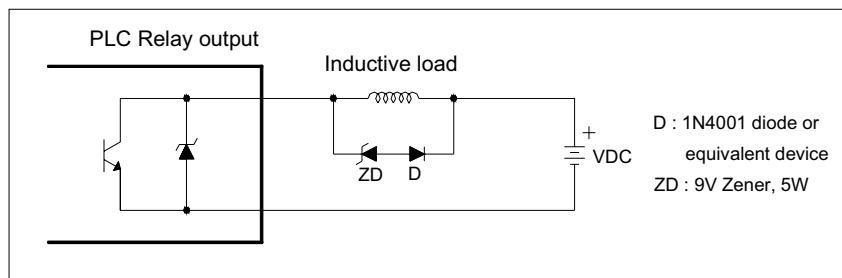

Suppress by a diode + Zener (high power and frequent ON/OFF)

Chapter 8 Test Run, Monitoring and Maintenance

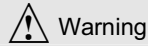

During maintenance, be sure to turn off the input power of PLC in case the actions to touch any terminal on PLC, or insert and extract accessories (e.g., expansion ribbon cables) is required. Otherwise, electric shock, short circuit, damaged PLC or PLC malfunction will be caused if the power is on.

8.1 Inspection after Wiring and Before First Time Power on

Before power on, clean all unnecessary objects such as iron chippings and screws, and remove the dust cover sheet that surround the FBS-PLC.

Make sure that the input power and PLC required power is of the same type. When input power is AC power, please pay attention to connect the hot wire (L) to the “L” terminal on PLC and the ground wire (N) to the “N” terminal. Mistakenly connect to DC powered PLC or to terminals other than “L” and “N” will result in electric shock, serious damage or malfunction.

Make sure the load power and PLC output circuits are consistent. Connection of AC power to transistor output or DC power to TRIAC output will damage PLC or result in malfunction.

Make sure the DC24V input and polarities of SINK/SOURCE in transistor output are consistent with those of your existing wiring. Any mismatch will result in failure of PLC input and damage to the output circuit.

8.2 Test Run and Monitoring

The FBS-PLC provides a convenient feature to Disable/Enable the I/O points by whole or individually. Namely, while PLC performs the normal logic scan operation and I/O refreshment, it does not update the status of the disabled input points according to the actual external input. For the disabled output points, the result of logic scan can't override the disable status of outputs, only the user can force the state to 'on' or 'off' in order to simulate its operation. The user only needs to utilize the disable function combined with Monitor to achieve simulating the input or output via FP-07C or WINPROLADDER and observe the result. Upon the finish the simulation, revert all the inputs or outputs to Enable state will bring back normal operation. Refer the instructions of WINPROLADDER or FR-07C for the operation of RUN/STOP PLC, Disable/Enable I/O and monitoring of I/O status and content of register.

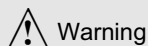

The disable function is to let the input or output status out of PLC program control and switched to the control of the user (tester) to freely set the disabled input or output to be ON or OFF. In normal PLC operation, when dealing with input or output with safety issues (such as upper/lower limit of detected input or output emergency stop), the user must make sure whether it can be disabled or overridden to ON/OFF before starting the disable or override control, to avoid damage to equipment or harm to people.

8.3 LED Indicators on PLC Main Unit and Troubleshooting

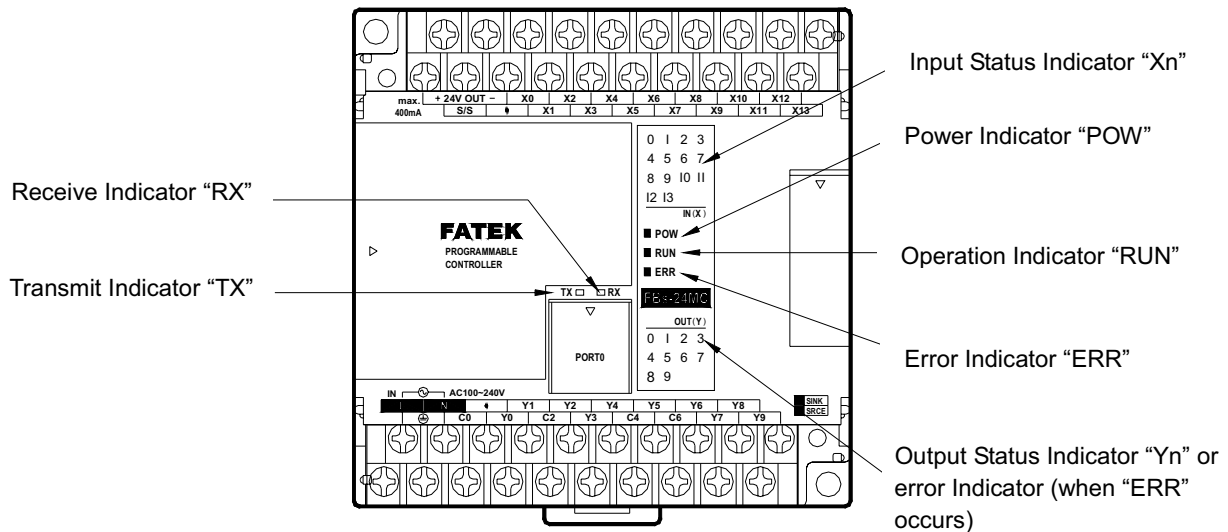

Power Indicator “POW”

After the PLC is power on, with correct power source and wiring, the “POW” LED indicator in the middle of the PLC nameplate will turn on, indicating that power supply is normal. If the indicator is not on, please try to temporarily remove the wiring of 24VDC output power for Sensor. If the LED is back to normal, it means that the load on the power for the 24VDC input circuit is too large so that PLC enters overload low voltage protection mode. (When PLC enters overload low voltage protection mode, “POW” LED is off and there are slight and intermittent low frequency hissing sounds, from which one can tell if the 24VDC power is overloaded or shorted.)

When the above method still cannot turn on the “POW” LED, if it is confirmed that correct power input exists between PLC power input L/N terminals or +/- (DC power), please send the unit to your local distributor for repair.

Operation Indicator “RUN”

As long as the CPU is working properly, in the STOP state, this indicator will go on and off for 2 seconds, respectively. When it's in the RUN state, the indicator will go on and off for 0.25 seconds, respectively. To make PLC enter into Run state, or switch from RUN to STOP state, it has to be done through the programmer (FP-07C or WINPROLADDER). Once PLC is set to RUN or STOP, it will keep that state even after power off. The only exception is, when using the ROM PACK, no matter if it's running or stopped before power off, PLC will automatically enter RUN state (with correct ROM PACK syntax check) when power is back. In normal operation of PLC upon errors (e.g., errors in WDT timer and program), PLC will automatically switch to STOP state and light the “ERR” error indicator. If it is a minor error, the RUN state can be resumed as long as the power is back after an outage. In case of serious errors, the PLC cannot be operated again with the programmer until the problem is solved. If PLC cannot be resumed to RUN state after all, please send it to your local distributor for repair.

Error Indicator “ERR”

In normal PLC operation, either in RUN or STOP state, this indicator will not show any signal (off). If it is on, it means that the system has an error (e.g., WDT time-out, program error, communication error, etc.)

If it is constantly on, please reset the power. If the situation is still the same, it implies a hardware failure in CPU and has to be sent to the distributor for repair.

When the ERR indicator flashes with a 0.5 sec interval, it means that some anomaly occurs to PLC. At the same time, status indicators Y0~Y3 switch to serve as indications of 15 error codes (the corresponding outputs are disabled), which are described in the following :

Y3	Y2	Y1	Y0	Error Code	Description
0	0	0	1	1	Application program contains the functions not supported by this CPU
0	0	1	0	2	Mismatch of PLC ID VS. program ID
0	0	1	1	3	Check sum error in LADDER program
0	1	0	0	4	System STACK abnormal
0	1	0	1	5	Watch-Dog occurs
0	1	1	0	6	Exceed main unit I/O
0	1	1	1	7	Syntax check error occurs
1	0	0	0	8	Expansion I/O modules over limit
1	0	0	1	9	Expansion I/O points over limit
1	0	1	0	10	System FLASH ROM CRC error
1	0	1	1	11	Reserved
1	1	0	0	12	Reserved
1	1	0	1	13	Reserved
1	1	1	0	14	Reserved
1	1	1	1	15	Reserved

Indicator on Transmit/Receive of Built-In Communication Port (Port0) "TX"、"RX"

These two LED indicators are used for the status of transmit/receive of the built-in communication port (Port0). The RX indicator (green) is for indication when PLC receives external signals, while the TX indicator (red) is for indication when PLC transmits signals, both of which are very helpful in monitoring communication condition and debugging. When PLC communicates with external equipment (computer, programmer, intelligent peripherals, etc.), Port0 in FBs-PLC can only be used in slave mode (Port1~4 can be used in master mode). Therefore, during its operation, PLC must first receive external signals (RX on) before it can transmit signals back to external equipment (TX on now). When the communication is fail, one can tell if it's PLC is not receiving signals or PCL is not replying by looking at the these two indicators. The currents in these two LED are constant and their lighting duration is proportional to the reception or transmission time. The more received/transmitted data or the slower (bps) reception/transmission, the longer the reception/transmission time and so is the indication time (brighter visually). If in high speed but small amount of data, only short and dim brightness is observed. Therefore, the communication condition can be easily distinguished by these two indicators.

Indicator of Input Status "Xn"

When external input Xn is ON, the corresponding LED indicator Xn will be on, otherwise it will be off. If it fails to respond to external input, please check if the terminal wiring is securely connected, or measure the voltage between "Xn" and common "C" to see if it has a change of 0V/22V with ON/OFF of input. If it does, it means that an error occurs in PLC input circuit or LED indicator. Or you can locate the problem by using the monitor mode of the programmer to check if this input status works correspondingly with the external input state.

Indicator of Output Status "Yn"

When the Yn output of PLC is ON, its corresponding output indicator will also be on and its external load will be ON. If ON/OFF condition of external load is inconsistent with output indicator, please check the wiring of the load, power, and terminal for secure connection. If the connection is good, then it should be the PLC output component failure. The main reasons to cause the output component failure are:

Overload or short circuit that burns output component and results in permanent open or short circuit.

Not overloaded, but Inrush current from capacitive load welds relay contacts at "ON", resulting in permanent ON, or burns transistor or TRIAC, resulting in permanent ON or OFF.

Not overloaded, but the inductive load without proper snubber circuit causes high voltage sparks between relay contact at "OFF" and generate carbon deposition, which separates contacts and causes permanent OFF or intermittent ON/OFF, or punches through transistor or TRIAC with high voltage, resulting in permanent ON or OFF.

8.4 Maintenance

FBs-PLC itself has no user serviceable parts and all maintenance has to be conducted by professional personnel. During use, in case of any defective unit, please first try to find out the defect from the above error codes on the main unit, followed by performing maintenance over the entire unit or on the Board level. Send the unit that is still not functioning well to local distributors.

8.5 The charge of battery & recycle of used battery

Every FBs –PLC main units have inside one re-chargeable lithium battery to safely maintain program and data during main power shut down. Each lithium battery was fully charged when the FBs-PLC ship out from the factory capable to retain program and data at least 6 months. There is risk to miss program and data when battery exhaust over 6 months, the users should mind the date marked on each FBs-PLC.

In case exceeding 6 months, users can do battery re-charging by themselves through keeping FBs-PLC be powered for over 12 hours then more 6 months can work smoothly on the data saving.

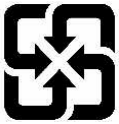
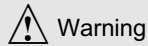

Any recharge, disassembly, heating, burning on defective or discarded battery is prohibited. Otherwise may cause danger of explosion or fire. The chemical material of battery will lead to environment pollution, easily throw away or treat as normal garbage is prohibited. Please follow after the local or government's regulation to make proper treatment on discard battery.