



**TBI MOTION TECHNOLOGY CO., LTD.**

No.91, Zhong Shan Rd., Tucheng Dist, New Taipei City,  
23680, Taiwan.(R.O.C.)

TEL : +886-2-22687211~4    E-mail : tbi.tbi@msa.hinet.net

FAX : +886-2-22687210    http : //www.tbimotion.com.tw

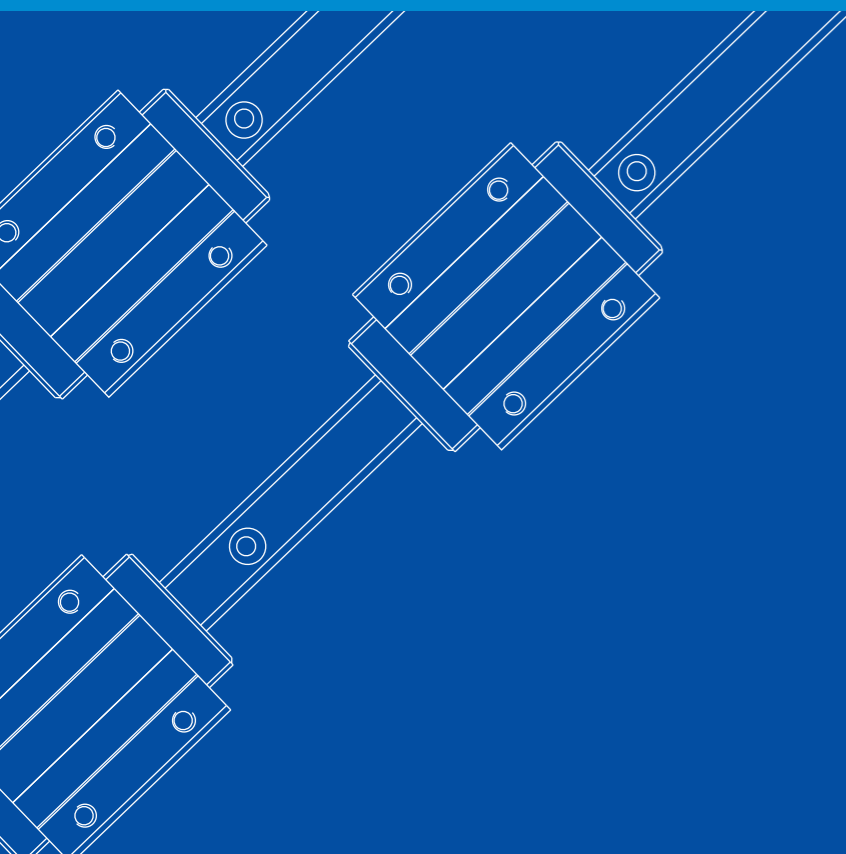

2013/05-2000

Note : The appearance and specification may be changed without prior notice only if the requirement improves performance.



LINEAR GUIDE Technical Manual

# LINEAR GUIDE CATALOG



# LINEAR GUIDE



● 1986



Taiwan Ball Screw Industrial Co.,Ltd. ( *TBI* ) was established in Tucheng Industrial District, Taipei, Taiwan. We were also the first manufacturer who produces ground type of precise ball screws in Taiwan.

● 1988

TBI established Research & Development Department and finished constructing the factory in Taichung that focuses on innovative products and producing precise grinding ball screws.

● 2002



**COMTOP** was established and exported ball screws to world wide based on a professional and successful marketing sales system.

● 2010



( *TBI MOTION* ) has integrated the technology of *TBI* and the marketing strategy of **COMTOP** to develop *TBI MOTION* in a leading place of Linear Motion Industry. The main products are Ball Screws, Linear Guides, Ball Splines, Single Axis Robot, Linear Ball Bearing, Couplings, and Ball Screw Accessories... etc.

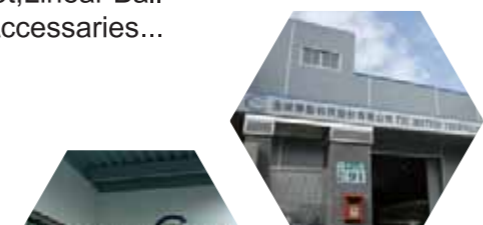

**Linear Guideway**

**1. General Information**

1-1 Advantage and Features of Linear Guide	1
1-2 The procedure of Selecting Linear Guide	4
1-3 Basic Load Rating and Service Life of Linear Guide	5
1-4 Working Load	13
1-5 Safety Factor and Load	19
1-6 Calculation of average working load	28
1-7 Calculation example	32
1-8 Installation of Linear Guide	42
1-9 Friction	54
1-10 Design of Rigidity	55
1-11 Accuracy	57
1-12 Lubrication	59
1-13 Precautions of Linear Guide	60

**2. TBI MOTION Linear Guide**

2-1 The Characteristics of TBI Linear Guide	61
2-2 TR Structure	62
2-3 TR Structure chose	62
2-4 TR Series	63
2-5 TR Codes	64
TRH-V Series Dimension Table	65
TRH-F Series Dimension Table	67
TRS-V Series Dimension Table	69
TRS-F Series Dimension Table	71
TRC-V Series Dimension Table	73
2-6 TM Structure	75
2-7 TM Codes	76
TM-N Series Dimension Table	77
2-8 The Standard length and maxima length of linear rail	79
2-9 Rail Type	79
2-10 Accuracy Level	81
2-11 Preload Methods	83
2-12 Lubrication	85
2-13 Dust Proof	88
2-14 Friction	89
2-15 Installation and Tolerance	90
TBI MOTION linear guide selection guidance	91

## 1-1 The Advantage of Linear Guide

### 1-1-1 High Accuracy

Because linear guide has little friction resistance, only a small driving force is needed to move the load. Low frictional resistance helps the temperature rising effect be small. Thus, the frictional resistance is decreased and the accuracy could be maintained for long period than traditional slide system.

### 1-1-2 High Rigidity

The design of Linear Guide rail and block features an equal lead rating in all four directions that request sufficient rigidity load in all directions, and self-aligning capability to absorb installation-error. Moreover, a sufficient preload can be achieved to increase rigidity and makes it suitable for any kind of installation.

### 1-1-3 Easy for Maintenance

Compared with high-skill required scrapping process of traditional slide system, the Linear Guide can offer high precision even if the mounting surface is machined by milling or grinding. Moreover the interchangeability of Linear Guide gives a convenience for installation and future maintenance.

### 1-1-4 High Speed

Linear Guide block, rail and ball apply by contact point of Rolling system. Due to the characteristic of low frictional resistance, the required driving force is much lower than that in other systems, thus the power consumption is small. Moreover, the temperature rising effect is small even under high speed operation.

### 1-1-5 High Performance without Clearance ( see Fig 1.1.1~1.1.4 )

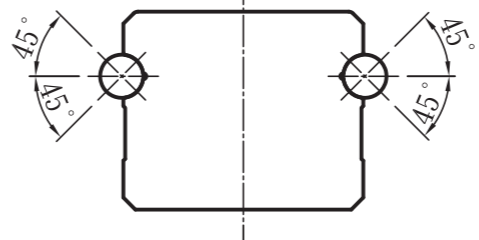
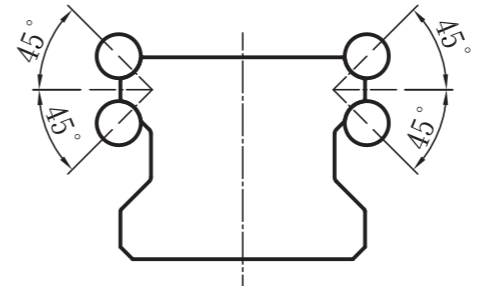
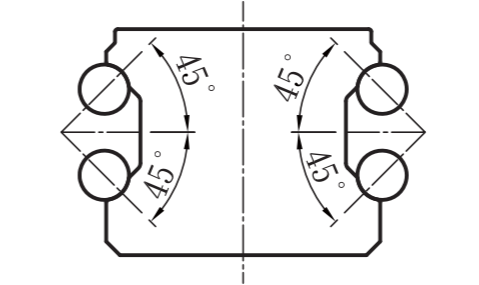
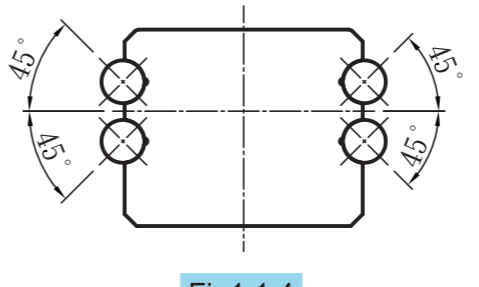
Drawing	Characteristics 、 Performance
 <p style="text-align: center;">Fig1.1.1</p>	<ul style="list-style-type: none"> <li>● Two trains of balls.</li> <li>● In a Gothic-arch groove, each ball contacts the raceway at four points 45°- 45°.</li> <li>● It has constant contact point between ball and arc groove.</li> <li>● Rigidity has high stability.</li> <li>● Two-row design is able to perform an equal load rating in four directions.</li> </ul>
 <p style="text-align: center;">Fig1.1.2</p>	<ul style="list-style-type: none"> <li>● Four trains of balls.</li> <li>● The circular-arc groove has two contact points at 45°- 45°(DF)-Four-Row Design features an equal load rating in all four directions with high rigidity.</li> <li>● Four-row design is able to perform an equal load rating in four directions.</li> <li>● Self-Aligning to absorb installation-error.</li> </ul>
 <p style="text-align: center;">Fig1.1.3</p>	<ul style="list-style-type: none"> <li>● Four trains of balls.</li> <li>● The circular-arc groove has two contact points at 45°- 45° (DB).</li> <li>● Four-Row Design features an equal load rating in all four directions with high rigidity.</li> <li>● Low friction resistance promotes smooth operating condition.</li> </ul>
 <p style="text-align: center;">Fig1.1.4</p>	<ul style="list-style-type: none"> <li>● Four trains of balls.</li> <li>● In the Gothic-arch groove, each ball contacts the raceway at two points 45°- 45°, Light preload, two contact points, Heavy preload, four contact points.</li> <li>● It contrasts with traditional DB type, which has better rigidity at permissible Moment.</li> </ul>



The Contract table of four-row design with equal load rating and two-row Gothic design.

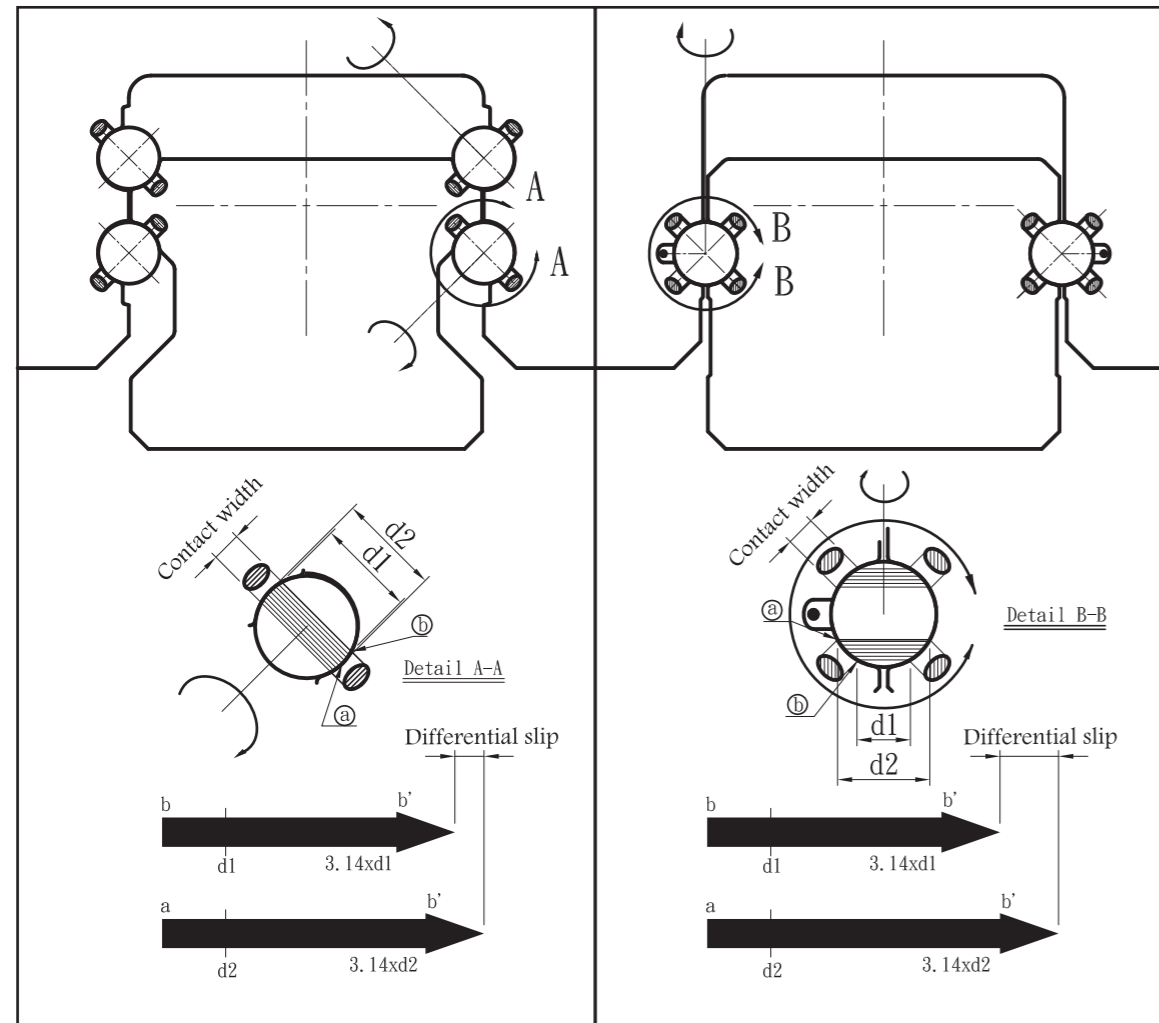

Table1.1.5 Four-Row Equal Load Rating Design.

Table1.1.6 Two-Row Gothic Design.

As shown in the diagrams, each time the ball rolls, a slip occurs in an amount equal to the difference between the circumferences of the inner and outer surfaces of the ball in contact with the raceway ( $\pi d1$ ) and ( $\pi d2$ ). (This slip is called the differential slip). When the circumferential difference is too large, a slip occurs when the ball rolls. The friction coefficient between the ball and the raceway is several times greater when slip occurs than when there is no slip and frictional resistance increases substantially. Even under a preload or regular load, the ball and raceway contact one another at two points in the loading direction, as shown. Thus the difference between  $d1$  and  $d2$  can be small, as can the differential slip. This design gives rise to a smooth rolling motion.

## 1-2 Selecting the Correct Type of Linear Guide Flowchart

### 1-2-1 Flowchart

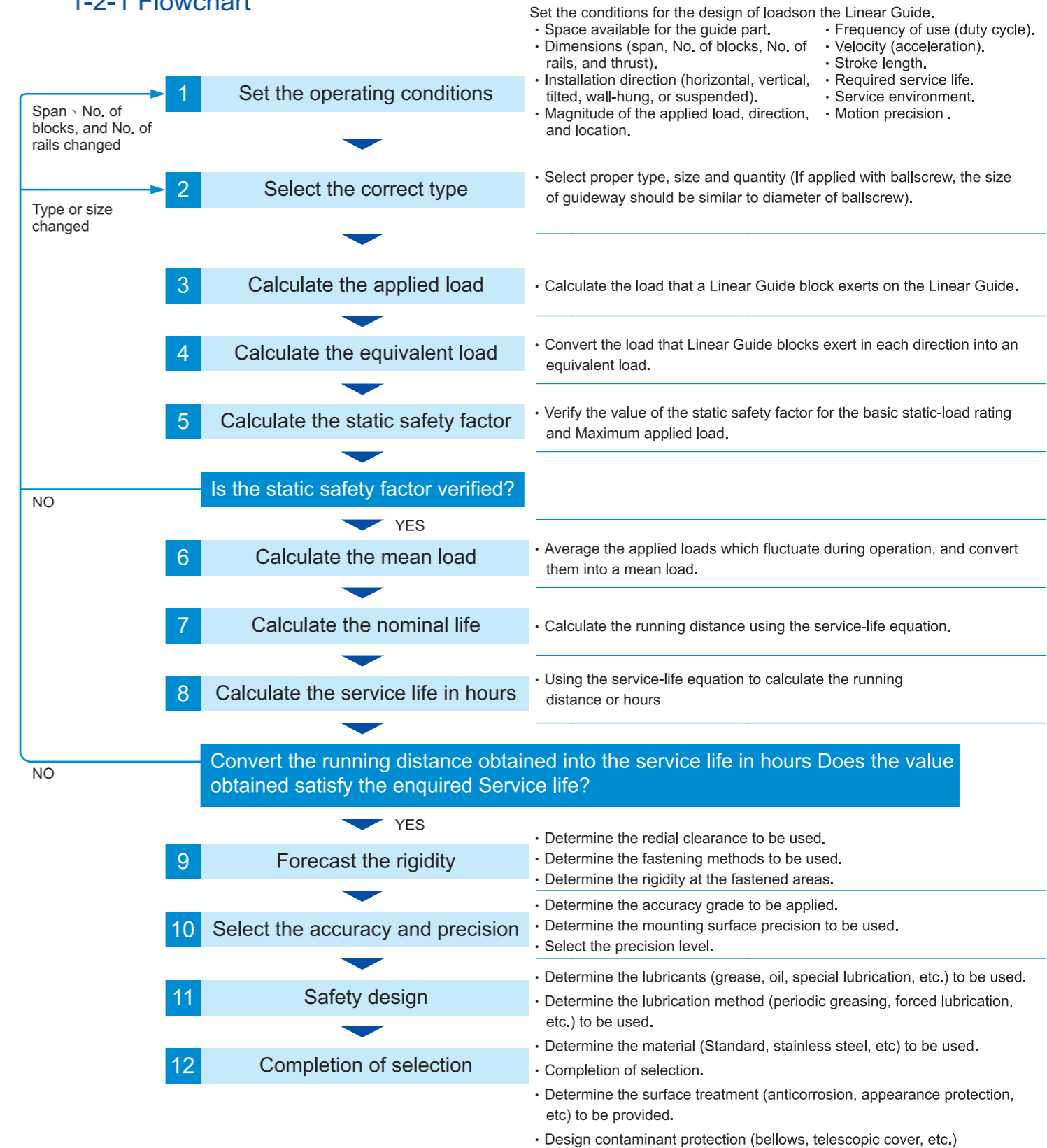



## 1-3 Load Rating and Service Life

When determining a model that would best suit your service conditions for a linear motion system, the load carrying capacity and service life of the model must be considered. To consider the load carrying capacity you should know the static safety factor of the model calculated based on the basic static load rating. Service life can be assessed by calculating the nominal life based on the basic dynamic load rating and checking to see if the values thus obtained meet your requirements.

The service life of a linear motion system refers to the total running distance that the linear motion system travels until flaking (the disintegration of a metal surface in scale-like pieces) occurs there to as a result of the rolling fatigue of the material caused by repeated stress on raceways and rolling elements.

Basic Load Rating : There are two basic load ratings for linear motion systems : basic static load rating( $C_0$ ), which sets the static permissible limits, and basic dynamic load rating ( $C$ ).

### 1-3-1 Basic Static Load Rating ( $C_0$ )

If a linear motion system, whether at rest or in motion, receives an excessive load or a large impact, a localized permanent set develops between the raceway and rolling elements. If the magnitude of the permanent set exceeds a certain limit, it hinders the smooth motion of the linear motion system.

The basic static load rating refers to a static load in a given direction with given magnitude such that the sum of the permanent set of the rolling elements and that of the raceway at the contact area under the most stress is 0.0001 times greater than the rolling element diameter. In linear motion systems, the basic static load rating is defined as the radial load. Thus the basic static load rating provides a limit on the static permissible load.

### 1-3-2 Basic Permissible Moment ( $M_x$ , $M_y$ , $M_z$ )

When a Linear Guide gets a force that makes the balls distorted to 1/10,000 of their diameter, we call the force as basic static permissible moment. Values of  $M_x$ ,  $M_y$ ,  $M_z$  are shown on Fig1.3.1, which suggest 3 axes of moment on a Linear Guide slide.

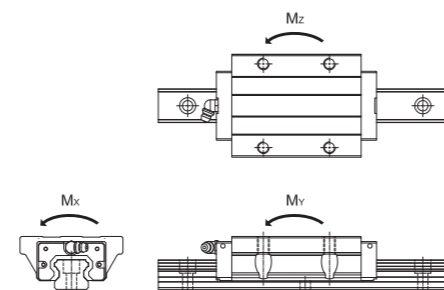

Fig1.3.1

### 1-3-3 Static Safety Factor $f_s$

A linear motion system may possibly receive an unpredictable external force due to vibration and impact while it is at rest or is moving or due to inertia resulting from start and stop. It is therefore necessary to consider the static safety factor against operating loads like these. The static safety factor ( $f_s$ ) indicates the ratio of a linear motion system load carrying capacity [ basic static load rating  $C_0$  ] to the load exerted there on.

$$f_s = \frac{C_0}{P} \text{ or } \frac{M_0}{M}$$

$f_s$  : static safety factor

$C_0$  : basic static load rating (N)

$M_0$  : static permissible moment (N-mm)

$P$  : calculated load (N)

$M$  : calculated moment (N-mm)

To calculate a load exerted on the Linear Guide, the mean load necessary for calculating the service life and the maximum load necessary for calculating the static safety factor must be obtained in advance. In a system that is subjected to frequent starts and stops and is placed under machining loads, and one upon which a moment due to an overhang load is forcefully exerted, an excessive, load greater than expected may develop. When selecting the correct type of Linear Guide for your purpose, be sure that the type you are considering can bear the maximum possible load, both when stopped and when in operation. The table below specifies the standard values for the static safety factor.

Table1.3.1 Static Safety Factor  $f_s$

Machine used	Loading conditions	$f_s$ lower limit
Ordinary industrial machine	Receives no vibration or impact	1.0 - 1.3
	Receives vibration and impact	2.0 - 3.0
Machine tool	Receives no vibration or impact	1.0 - 1.5
	Receives vibration and impact	2.5 - 7.0

For large radial loads	$\frac{f_h \cdot f_t \cdot f_c \cdot C_0}{P_R} \geq f_s$
For large reverse-radial loads	$\frac{f_h \cdot f_t \cdot f_c \cdot C_{0L}}{P_L} \geq f_s$
For large lateral loads	$\frac{f_h \cdot f_t \cdot f_c \cdot C_{0T}}{P_T} \geq f_s$

$f_s$  : Static safety factor

$C_0$  : Basic static-load rating (radial) (N)

$C_{0L}$  : Basic static-load rating (reverse-radial) (N)

$C_{0T}$  : Basic static-load rating (lateral) (N)

$P_R$  : Calculated load (radial) (N)

$P_L$  : Calculated load (reverse-radial) (N)

$P_T$  : Calculated load (lateral) (N)

$f_h$  : Hardness factor (Fig1.3.2)

$f_t$  : Temperature factor (Fig1.3.3)

$f_c$  : Contact factor (Table1.3.2)

### 1-3-4 Service life (L)

Even when identical linear guideways in a group are manufactured in the same way or applied under the same condition, the service life may be varied. Thus, the service life is used as an indicator for determining the service life of a linear guideway system. The nominal life (L) is defined as the total running distance that 90% of identical linear guideways in a group, when they are applied under the same conditions, can work without developing laking.

### 1-3-5 Basic Dynamic Load Rating (C)

Basic dynamic load rating (C) can be used to calculate the service life when linear guideway system response to a load. The basic dynamic load rating (C) is defined as a load in a given direction and with a given magnitude that when a group of linear guideways operate under the same conditions. As the rolling element is ball, the nominal life of the linear guideway is 50 km. Moreover, as the rolling element is roller, the nominal life is 100 km.

### 1-3-6 Calculation of Nominal Life

The service lives of linear motion systems more or less vary from system to system even if they are manufactured to the same specifications and remain in service under the same operating conditions. Hence a guideline for determining the service life of a linear motion system is given based on nominal life, which is defined as follows. The nominal life refers to the total running distance that 90% of identical linear motion systems in a group, when interlocked with one another under the same conditions, can achieve without developing flaking. The nominal life(L) of a linear motion system can be obtained from the basic dynamic load rating (C) and load imposed (P) using the following equations.

For a linear motion system with balls

$$L = \left( \frac{f_h \cdot f_t \cdot f_c}{f_w} \cdot \frac{C}{P_c} \right)^3 \cdot 50$$

For a linear motion system with rollers

$$L = \left( \frac{f_h \cdot f_t \cdot f_c}{f_w} \cdot \frac{C}{P_c} \right)^{10} \cdot 100$$

### Service-Life Equation

The service life of the Linear Guide can be obtained using the following equation :

$$L = \left( \frac{f_h \cdot f_t \cdot f_c}{f_w} \cdot \frac{C}{P_c} \right)^3 \cdot 50$$

(total distance that can be traveled by at least 90% of a group of Linear Guide operated under the same conditions)

- C : basic dynamic-load rating (N)
- P<sub>c</sub> : calculated load (N)
- f<sub>h</sub> : hardness factor (Fig1.3.2)
- f<sub>t</sub> : temperature factor (Fig1.3.3)
- f<sub>c</sub> : contact factor (Table1.3.3)
- f<sub>w</sub> : load factor (Table1.3.4)

(Once nominal life (L) is obtained using this equation. The Linear Guide service life can be calculated by using the following equation if the stroke length and the number of reciprocating cycles are constant :

$$L_h = \frac{L \cdot 10^6}{2 \cdot \ell_s \cdot n_1 \cdot 60}$$

- L<sub>h</sub> : service life in hours (h)
- ℓ<sub>s</sub> : stroke length (mm)
- n<sub>1</sub> : No. of reciprocating cycles per min (min<sup>-1</sup>)

### 【f<sub>h</sub> : Hardness factor】

To ensure achievement of the optimum load-bearing capacity of the Linear Guide, the raceway hardness must be 58~64HRC. At a hardness below this range, the basic dynamic and Static-load ratings decrease.

The ratings must therefore be multiplied by the

respective hardness factors (f<sub>h</sub>). As the Linear Guide has sufficient hardness, f<sub>h</sub> for the Linear Guide is 1.0 unless otherwise specified.

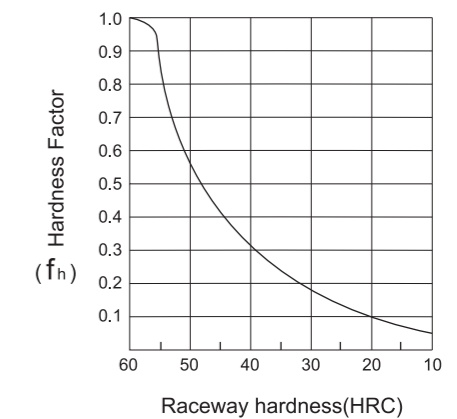

Fig1.3.2 Hardness Factor (f<sub>h</sub>)

### 【f<sub>t</sub> : Temperature factor】

For Linear Guide used at ambient temperatures over 100°C, a temperature factor corresponding to the ambient temperature, selected from the diagram below, must be taken into consideration. In addition, please note that selected Linear Guide itself must be a model with high-temperature specifications.

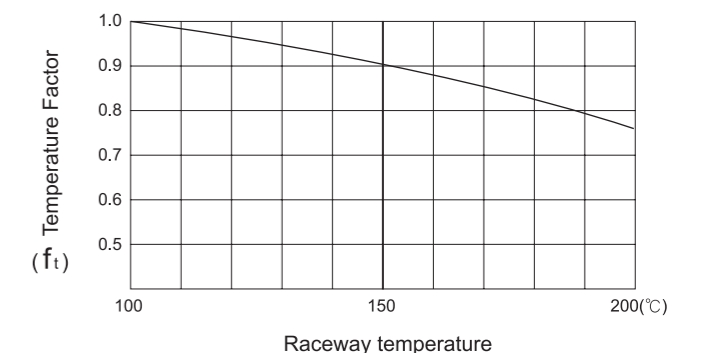

Fig1.3.3 Temperature Factor (f<sub>t</sub>)

(Note:When used at ambient temperatures higher than 80°C, the seals, end plates, and ball cages used must be changed to those with high-temperature specifications.)

## 【 $f_c$ : Contact factor】

When multiple Linear Guide blocks are used laid over one another, moments and mounting-surface precision will affect operation, making it difficult to achieve uniform load distribution. For Linear Guide blocks used laid over one another, multiply the basic load rating (C), ( $C_0$ ) by a contact factor selected from the table below.

Table 1.3.2

No. of blocks used	Contact factor ( $f_c$ )
2	0.81
3	0.72
4	0.66
5	0.61
6 or more	0.6
In normal use	1

Note: When the non-uniform load distribution can be predicted, as in a large system, consider using a contact factor.

## 【 $f_w$ : Load factor】

In general, machines in reciprocal motion are likely to cause vibration and impact during operation, and it is particularly difficult to determine the magnitude of vibration that develops during high-speed operation as well as that of impact during repeated starting and stopping in normal use. Therefore, where the effects of speed and vibration are estimated to be significant divide the basic dynamic-load rating (C) by a load factor selected from the table below.

Table 1.3.3 Load Factor ( $f_w$ )

Vibration and impact	Velocity(V)	$f_w$
Very Slight	Very Low $V \leq 0.25\text{m/s}$	1~1.2
Slight	Low $0.25 < V \leq 1\text{m/s}$	1.2~1.5
Moderate	Medium $1 < V \leq 2\text{m/s}$	1.5~2
Strong	High $V > 2\text{m/s}$	2~3.5

## Calculation Examples :

Application : Machine Center

Block model number : TRH30FE (Basic static load  $C_0=88.329\text{kN}$ , Basic dynamic load  $C=47\text{kN}$ )

The calculated load  $P_c=2614\text{N}$

The formula of calculating the life time by travel is

$$L = \left( \frac{f_h \cdot f_t \cdot f_c}{f_w} \cdot \frac{C}{P_c} \right)^3 \cdot 50 \text{ km}$$

Since using only 1 block in this application, we take  $f_c=1$

Supposed the speed is not very high between 0.25~1m/s, so we take  $f_w=1.5$

The temperature of working environment is under 100°C. The temperature factor  $f_T=1$

The hardness of raceway is 58~64 HRC, so the hardness  $f_H=1$

With all above data, the life time by travel of this application  $L = 86112\text{km}$

To calculate the life time by using hours :

We supposed the distance of travel  $L_s = 3000\text{mm}$

Times (Back and forth) per mins  $N_1 = 4 \text{ (min}^{-1}\text{)}$

The life time by travel is 86112km. the distance of travel is 3m (3000mm), so each back and forth is 6m.

The total times of back and forth would be  $86112 \times 1000 / 6 = 14352044$

The life time by using minutes is  $14352044 / 4 = 3588011 \text{ mins} = 59800 \text{ hours}$



## 1-3-7 Service-Life Equation L<sub>h</sub>

The Service Life can be calculated by operating term and velocity Nominal Life.

$$L_h = \left( \frac{L \cdot 10^3}{V_e \cdot 60} \right) = \frac{\left( \frac{C}{P} \right)^3 \cdot 50 \cdot 10^3}{V_e \cdot 60} \cdot \text{hr}$$

L<sub>h</sub> : Service Life in Hour

L : Nominal life(km)

V<sub>e</sub> : Velocity(m/min)

C/P : Load Ratio

### Calculating Life Time

Formula (A) calculating hour

L<sub>n</sub> : Lifetime (h)

L : Nominal life (km)

L<sub>s</sub> : Distance of travel (mm)

N1 : Times of travel per minute (min<sup>-1</sup>)

$$L_n = \frac{L \cdot 10^6}{2 \cdot L_s \cdot N1 \cdot 60}$$

Formula (B) calculating year

L<sub>y</sub> : Lifetime (year)

L : Nominal life (km)

L<sub>s</sub> : Distance of travel (mm)

N1 : Times of travel per minute (min<sup>-1</sup>)

M<sub>n</sub> : Minutes of running per day (hr/day)

H<sub>n</sub> : Hours of running per day (hr/day)

D<sub>n</sub> : Days of running per year (day/year)

$$L_y = \frac{L \cdot 10^6}{2 \cdot L_s \cdot N1 \cdot M \cdot H \cdot D}$$

**Example 1 :** There is a working station using linear guides with a nominal life of 45000 km, how should we calculate its service life in hours.

Known :

L<sub>s</sub> : Distance of travel = 3000mm (mm)

N1 : 4 times of travel per minute (min<sup>-1</sup>)

$$L_n = \frac{L \cdot 10^6}{2 \cdot L_s \cdot N1 \cdot M \cdot H \cdot D} = \frac{45000 \cdot 10^6}{2 \cdot 3000 \cdot 4 \cdot 60} = 31250 \text{ hr}$$

**Example 2 :** There is a working station using linear guides with a nominal life 7123.5 km, how should we calculate its service life in hours.

Known :

L<sub>s</sub> : Distance of travel = 4000mm (mm)

N1 : 5 times of travel per minute (min<sup>-1</sup>)

M<sub>s</sub> : Running 60 mins per hour (min/hr)

H<sub>s</sub> : Running 24 hours per day (hr/day)

D<sub>s</sub> : Running 360 days per year (day/year)

$$L_n = \frac{L \cdot 10^6}{2 \cdot L_s \cdot N1 \cdot M \cdot H \cdot D} = \frac{7123.5 \cdot 10^6}{2 \cdot 4000 \cdot 5 \cdot 60 \cdot 24 \cdot 360} = 3.435 \text{ hr}$$

## 1-4 Working Load

### 1-4-1 Working Load

The load applied to the Linear Guide, varies with the external force exerted thereon, such as the location of the center of gravity of an object being moved, the location of the thrust developed, inertia due to acceleration and deceleration during starting and stopping, and the machining resistance. To select the correct type of Linear Guide, the magnitude of applied loads must be determined in consideration of the above conditions to calculate accurate applied load.

To obtain the magnitude of an applied load and the service life in hours, the operating conditions of the Linear Guide system must first be set.

- (1) Mass : m (kg)
- (2) Direction of the action load
- (3) Location of the action point (e.g., center of gravity) :  $L_2$   $L_3$   $h_1$  (mm)
- (4) Location of the thrust developed :  $L_4$   $h_2$  (mm)
- (5) Linear Guide system arrangement :  $L_0$   $L_1$  (mm)
- (6) Velocity diagram  
Velocity : V (mm/s)  
Time constant :  $t_n$  (s)  
Acceleration :  $a_n$  ( $\text{mm/s}^2$ )  
 $a_n = \left(\frac{V}{t_n}\right)$   
Gravitational acceleration  $g = 9.8 \text{ m/s}^2$
- (7) Duty cycle (No: of reciprocating cycles per min) :  $N_1$  ( $\text{min}^{-1}$ )
- (8) Stroke length : L (mm)
- (9) Mean velocity :  $V_m$  (mm/s)
- (10) Required service life in hours :  $L_h$  (h)

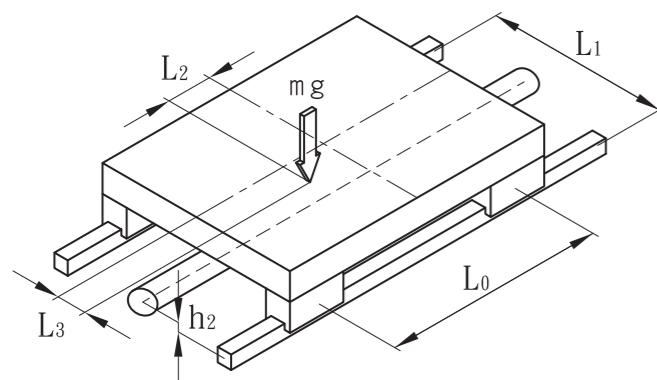

Fig1.4.1

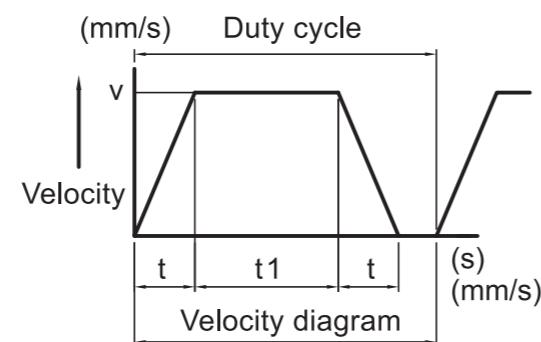

Fig1.4.2

### Calculating the Working Load

The load applied to the Linear Guide varies with the external force exerted thereon, such as the location of the center of gravity of an object being moved, the location of the thrust developed, inertia due to acceleration and deceleration during starting and stopping, and the machining resistance. To select the correct type of Linear Guide, the magnitude of applied loads must be determined in consideration of the above conditions. Using the following Table1.4.1, we will now calculate the loads applied to the Linear Guide.

m : Mass	(kg)	g : Gravitational acceleration ( $\text{m/s}^2$ )	( $g=9.8\text{m/s}^2$ )
$L_n$ : Distance	(mm)	V : Velocity	(m/s)
$F_n$ : External force	(N)	$t_n$ : Time constant	(s)
$P_n$ : Applied load	(N)	$a_n$ : Acceleration	( $\text{m/s}^2$ )
(radial and reverse-radial directions)		$a_n = \left(\frac{V}{t_n}\right)$	
$P_{nT}$ : Applied load	(mm)		

Table1.4.1

NO.	Operating conditions	Equation for calculating applied load
1	Install in a horizontal position. (Move the block) Measure in uniform motion or at rest.	$F_1 = \frac{mg}{4} + \frac{mg \cdot L_2}{2 \cdot L_0} - \frac{mg \cdot L_3}{2 \cdot L_1}$ $F_2 = \frac{mg}{4} - \frac{mg \cdot L_2}{2 \cdot L_0} - \frac{mg \cdot L_3}{2 \cdot L_1}$ $F_3 = \frac{mg}{4} - \frac{mg \cdot L_2}{2 \cdot L_0} + \frac{mg \cdot L_3}{2 \cdot L_1}$ $F_4 = \frac{mg}{4} + \frac{mg \cdot L_2}{2 \cdot L_0} + \frac{mg \cdot L_3}{2 \cdot L_1}$
2	Install in an overhung horizontal position. (Move the block) Measure in uniform motion or at rest.	$F_1 = \frac{mg}{4} + \frac{mg \cdot L_2}{2 \cdot L_0} + \frac{mg \cdot L_3}{2 \cdot L_1}$ $F_2 = \frac{mg}{4} - \frac{mg \cdot L_2}{2 \cdot L_0} + \frac{mg \cdot L_3}{2 \cdot L_1}$ $F_3 = \frac{mg}{4} - \frac{mg \cdot L_2}{2 \cdot L_0} - \frac{mg \cdot L_3}{2 \cdot L_1}$ $F_4 = \frac{mg}{4} + \frac{mg \cdot L_2}{2 \cdot L_0} - \frac{mg \cdot L_3}{2 \cdot L_1}$

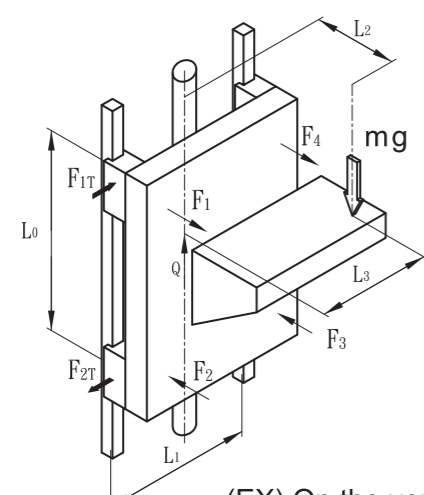
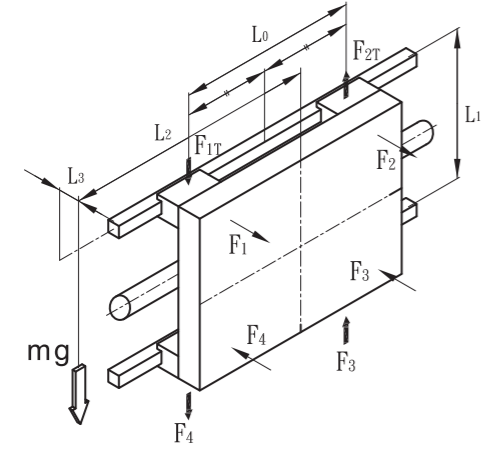
NO.	Operating conditions	Equation for calculating applied load
3	<p>Install in a vertical position. Measure in uniform motion or at rest.</p>  <p>(EX) On the vertical axis of industrial robots in automatic painting machines and lifters.</p>	$F_1 = F_2 = F_3 = F_4 = \frac{mg \cdot L_2}{2 \cdot L_0}$ $F_{1T} = F_{2T} = F_{3T} = F_{4T} = \frac{mg \cdot L_3}{2 \cdot L_0}$
4	<p>On a wall. Measure in uniform motion or at rest.</p>  <p>(EX) On cross rails loader travel axis.</p>	$F_1 = F_2 = F_3 = F_4 = \frac{mg \cdot L_3}{2 \cdot L_1}$ $F_{1T} = F_{4T} = \frac{mg}{4} + \frac{mg \cdot L_2}{2 \cdot L_0}$ $F_{2T} = F_{3T} = \frac{mg}{4} - \frac{mg \cdot L_2}{2 \cdot L_0}$

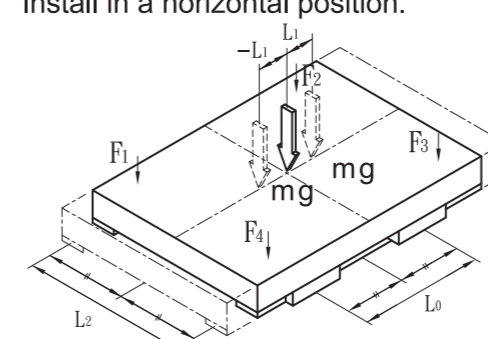
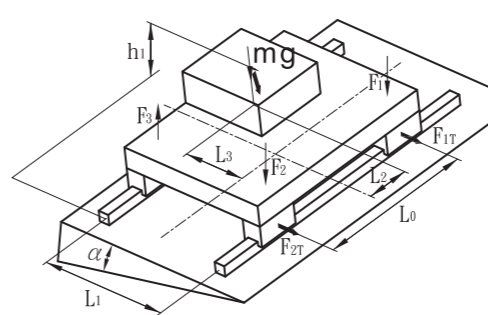
NO.	Operating conditions	Equation for calculating applied load
5	<p>Move on Linear Guide rail Install in a horizontal position.</p>  <p>(EX) XY table / Sliding fork.</p>	$F_{1max} = F_{2max} = F_{3max} = F_{4max} = \frac{mg}{4} + \frac{mg \cdot L_1}{2 \cdot L_0}$ $F_{1min} = F_{2min} = F_{3min} = F_{4min} = \frac{mg}{4} - \frac{mg \cdot L_1}{2 \cdot L_0}$
6	<p>Install in a laterally tilted position.</p>  <p>(EX) NC lathe / Carriage (for the lathe).</p>	$F_1 = + \frac{mg \cdot \cos \theta}{4} + \frac{mg \cdot \cos \theta \cdot L_2}{2 \cdot L_0} - \frac{mg \cdot \cos \theta \cdot L_3}{2 \cdot L_1} + \frac{mg \cdot \sin \theta \cdot h_1}{2 \cdot L_1}$ $F_{1T} = \frac{mg \cdot \sin \theta}{4} + \frac{mg \cdot \sin \theta \cdot L_2}{2 \cdot L_0}$ $F_2 = + \frac{mg \cdot \cos \theta}{4} - \frac{mg \cdot \cos \theta \cdot L_2}{2 \cdot L_0} - \frac{mg \cdot \cos \theta \cdot L_3}{2 \cdot L_1} + \frac{mg \cdot \sin \theta \cdot h_1}{2 \cdot L_1}$ $F_{2T} = \frac{mg \cdot \sin \theta}{4} - \frac{mg \cdot \sin \theta \cdot L_2}{2 \cdot L_0}$ $F_3 = + \frac{mg \cdot \cos \theta}{4} - \frac{mg \cdot \cos \theta \cdot L_2}{2 \cdot L_0} + \frac{mg \cdot \cos \theta \cdot L_3}{2 \cdot L_1} - \frac{mg \cdot \sin \theta \cdot h_1}{2 \cdot L_1}$ $F_{3T} = \frac{mg \cdot \sin \theta}{4} - \frac{mg \cdot \sin \theta \cdot L_2}{2 \cdot L_0}$ $F_4 = + \frac{mg \cdot \cos \theta}{4} + \frac{mg \cdot \cos \theta \cdot L_2}{2 \cdot L_0} + \frac{mg \cdot \cos \theta \cdot L_3}{2 \cdot L_1} - \frac{mg \cdot \sin \theta \cdot h_1}{2 \cdot L_1}$ $F_{4T} = \frac{mg \cdot \sin \theta}{4} + \frac{mg \cdot \sin \theta \cdot L_2}{2 \cdot L_0}$

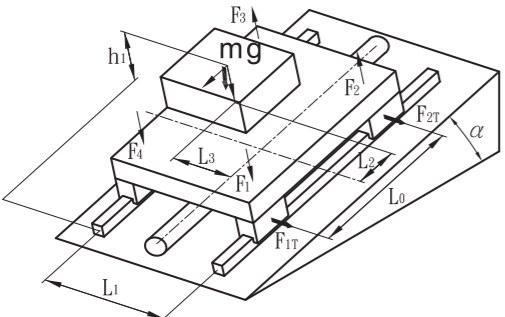
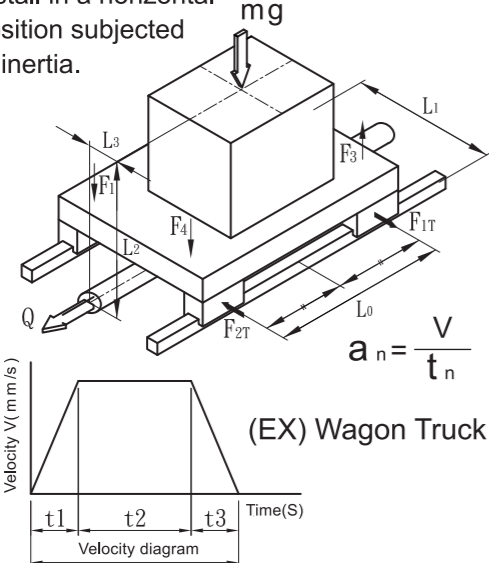

NO.	Operating conditions	Equation for calculating applied load
7	<p>Install in a longitudinally tilted position.</p>  <p>(EX) NC lathe / Tool res (for the lathe).</p>	$F_1 = + \frac{mg \cdot \cos \theta}{4} + \frac{mg \cdot \cos \theta \cdot L_2}{2 \cdot L_0} - \frac{mg \cdot \cos \theta \cdot L_3}{2 \cdot L_1} + \frac{mg \cdot \sin \theta \cdot h_1}{2 \cdot L_0}$ $F_{1T} = + \frac{mg \cdot \sin \theta \cdot L_3}{2 \cdot L_0}$ $F_2 = + \frac{mg \cdot \cos \theta}{4} - \frac{mg \cdot \cos \theta \cdot L_2}{2 \cdot L_0} - \frac{mg \cdot \cos \theta \cdot L_3}{2 \cdot L_1} - \frac{mg \cdot \sin \theta \cdot h_1}{2 \cdot L_0}$ $F_{2T} = - \frac{mg \cdot \sin \theta \cdot L_3}{2 \cdot L_0}$ $F_3 = + \frac{mg \cdot \cos \theta}{4} - \frac{mg \cdot \cos \theta \cdot L_2}{2 \cdot L_0} + \frac{mg \cdot \cos \theta \cdot L_3}{2 \cdot L_1} - \frac{mg \cdot \sin \theta \cdot h_1}{2 \cdot L_0}$ $F_{3T} = - \frac{mg \cdot \sin \theta \cdot L_3}{2 \cdot L_0}$ $F_4 = + \frac{mg \cdot \cos \theta}{4} + \frac{mg \cdot \cos \theta \cdot L_2}{2 \cdot L_0} + \frac{mg \cdot \cos \theta \cdot L_3}{2 \cdot L_1} + \frac{mg \cdot \sin \theta \cdot h_1}{2 \cdot L_0}$ $F_{4T} = + \frac{mg \cdot \sin \theta \cdot L_3}{2 \cdot L_0}$
8	<p>Install in a horizontal position subjected to inertia.</p>  <p>(EX) Wagon Truck.</p>	<p>During acceleration</p> $F_1 = F_4 = \frac{mg}{4} - \frac{mg \cdot a_1 \cdot L_2}{2 \cdot L_0 \cdot g}$ $F_2 = F_3 = \frac{mg}{4} + \frac{mg \cdot a_1 \cdot L_2}{2 \cdot L_0 \cdot g}$ $F_{1T} = F_{2T} = F_{3T} = F_{4T} = \frac{mg \cdot a_1 \cdot L_3}{2 \cdot L_0 \cdot g}$ <p>In uniform motion</p> $F_1 = F_2 = F_3 = F_4 = \frac{mg}{4}$ <p>During deceleration</p> $F_1 = F_4 = \frac{mg}{4} - \frac{mg \cdot a_3 \cdot L_2}{2 \cdot L_0 \cdot g}$ $F_2 = F_3 = \frac{mg}{4} + \frac{mg \cdot a_3 \cdot L_2}{2 \cdot L_0 \cdot g}$ $F_{1T} = F_{2T} = F_{3T} = F_{4T} = \frac{mg \cdot a_3 \cdot L_3}{2 \cdot L_0 \cdot g}$

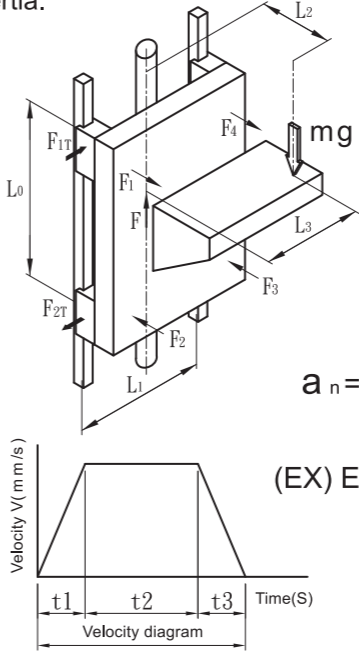
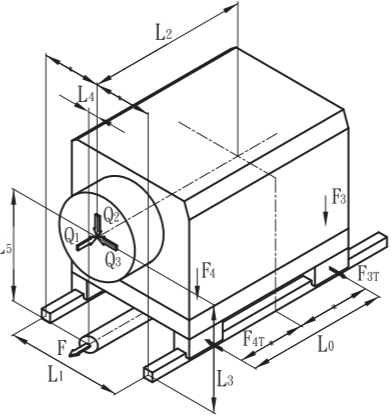
NO.	Operating conditions	Equation for calculating applied load
9	<p>Mount in a vertical position subjected to inertia.</p>  <p>(EX) Elevator.</p>	<p>During acceleration</p> $F_1 = F_2 = F_3 = F_4 = \frac{(mg + mg \cdot a_1/g) \cdot L_2}{2 \cdot L_0}$ $F_{1T} = F_{2T} = F_{3T} = F_{4T} = \frac{(mg + mg \cdot a_1/g) \cdot L_3}{2 \cdot L_0}$ <p>In uniform motion</p> $F_1 = F_2 = F_3 = F_4 = \frac{mg \cdot L_2}{2 \cdot L_0}$ $F_{1T} = F_{2T} = F_{3T} = F_{4T} = \frac{mg \cdot L_3}{2 \cdot L_0}$ <p>During deceleration</p> $F_1 = F_2 = F_3 = F_4 = \frac{(mg - mg \cdot a_3/g) \cdot L_2}{2 \cdot L_0}$ $F_{1T} = F_{2T} = F_{3T} = F_{4T} = \frac{(mg - mg \cdot a_3/g) \cdot L_3}{2 \cdot L_0}$
10	<p>Install on a horizontal position subjected to external force.</p>  <p>(EX) Drill unit / Milling machine / Lathe / Machining center and similar cutting machine.</p>	<p>Under force Q1</p> $F_1 = F_2 = F_3 = F_4 = \frac{Q_1 \cdot L_5}{2 \cdot L_0}$ $F_{1T} = F_{2T} = F_{3T} = F_{4T} = \frac{Q_1 \cdot L_4}{2 \cdot L_0}$ <p>Under force Q2</p> $F_1 = F_4 = \frac{Q_2}{4} + \frac{Q_2 \cdot L_2}{2 \cdot L_0}$ $F_2 = F_3 = \frac{Q_2}{4} - \frac{Q_2 \cdot L_2}{2 \cdot L_0}$ <p>Under force Q3</p> $F_1 = F_2 = F_3 = F_4 = \frac{Q_3 \cdot L_3}{2 \cdot L_1}$ $F_{1T} = F_{4T} = \frac{Q_3}{4} + \frac{Q_3 \cdot L_2}{2 \cdot L_0}$ $F_{2T} = F_{3T} = \frac{Q_3}{4} - \frac{Q_3 \cdot L_2}{2 \cdot L_0}$

## 1-5 Safety Factor and Load

### 1-5-1 Equivalent Factors of Linear Guide Block

Where a sufficient installation space is not available you may be obliged to use just one Linear Guide block or two Linear Guide blocks laid over one another for the Linear Guide. In such a setting, the load distribution cannot be uniform and, as a result, an excessive load is exerted in localized areas (e.g., rail ends). Continued use under such conditions may result in flaking in those areas, consequently shortening the service life. In such a case, calculate true load by multiplying the moment value by any one of the moment-equivalent factors specified in Tables.

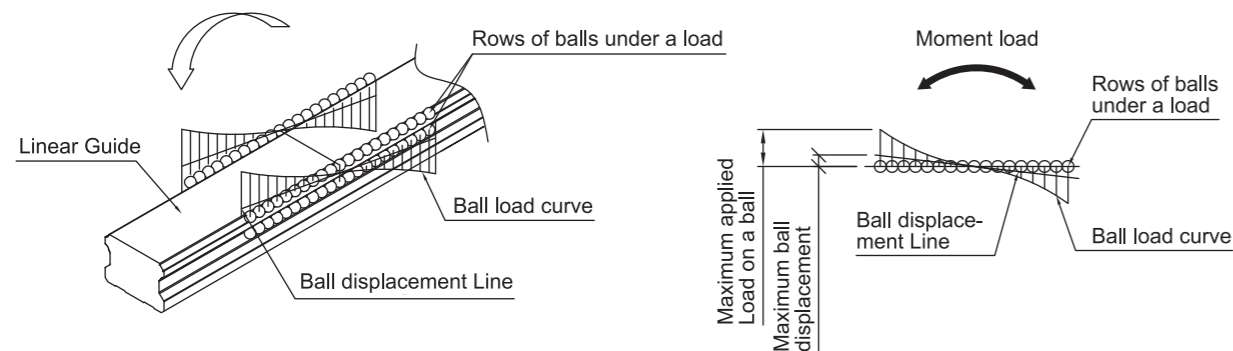

Fig.1.5.1 Ball Load Effected by a Moment

An equivalent-load equation applicable when a moment acts on a Linear Guides is shown below.

$$P=K.M$$

P : equivalent load per Linear Guide (kgf)

K : equivalent moment factor ( $\text{mm}^{-1}$ )

M : developed moment (kgf · mm)

$K_A$ 、 $K_B$ 、 $K_C$  represent the equivalent moment factors in directions  $M_A$ 、 $M_B$  and  $M_C$  respectively.

### Calculation Examples

Two Linear Guide blocks are used laid over one another.

Model No : TRH30FE

Gravitational Acceleration  $g = 9.8\text{m/s}^2$

Mass  $w = 5\text{kgf}$

$M_C = 5 \cdot 150 = 750 \text{ (kgf}\cdot\text{mm)}$

$M_A = 5 \cdot 200 = 1000 \text{ (kgf}\cdot\text{mm)}$

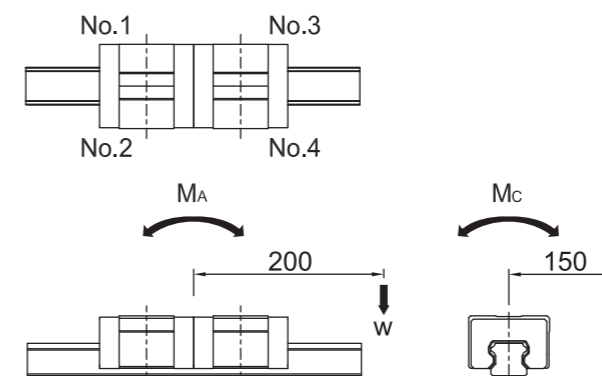

Fig.1.5.2

$$P_1 = K_c \cdot \frac{M_c}{2} + K_A \cdot M_A + \frac{W}{2} = 7.15 \cdot 10^{-2} \cdot \frac{750}{2} + 1.3 \cdot 10^{-2} \cdot 1000 + \frac{5}{2} = 42.3 \text{ (kgf)}$$

$$P_2 = -K_c \cdot \frac{M_c}{2} + K_A \cdot M_A + \frac{W}{2} = -7.15 \cdot 10^{-2} \cdot \frac{750}{2} + 1.3 \cdot 10^{-2} \cdot 1000 + \frac{5}{2} = -11.3 \text{ (kgf)}$$

$$P_3 = K_c \cdot \frac{M_c}{2} - K_A \cdot M_A + \frac{W}{2} = 7.15 \cdot 10^{-2} \cdot \frac{750}{2} - 1.3 \cdot 10^{-2} \cdot 1000 + \frac{5}{2} = 16.3 \text{ (kgf)}$$

$$P_4 = -K_c \cdot \frac{M_c}{2} - K_A \cdot M_A + \frac{W}{2} = -7.15 \cdot 10^{-2} \cdot \frac{750}{2} - 1.3 \cdot 10^{-2} \cdot 1000 + \frac{5}{2} = -37.3 \text{ (kgf)}$$

Note:

1. Since a Linear Guide in a vertical position receives only a moment load, there is no need to apply other loads (w).
2. In some models, load ratings differ depending on the direction of the applied load. With such a model, calculate an equivalent load in a direction in which conditions are comparably bad.

Table1.5.1 TRH-F

Model No.	Equivalent Factors Ka (mm <sup>-1</sup> )		Equivalent Factors Kb (mm <sup>-1</sup> )		Equivalent Factors Kc (mm <sup>-1</sup> )
	Equivalent Load Calculation for a system Using One Linear Guide Block	Equivalent Load Calculation for a system Using Two Linear Guide Blocks laid Over One-Another	Equivalent Load Calculation for a system Using One Linear Guide Block	Equivalent Load Calculation for a system Using Two Linear Guide Blocks laid Over One-Another	
TRH15FN	1.48 x 10 <sup>-1</sup>	3.11 x 10 <sup>-2</sup>	1.48 x 10 <sup>-1</sup>	3.11 x 10 <sup>-2</sup>	1.34 x 10 <sup>-1</sup>
TRH15FL	1.26 x 10 <sup>-1</sup>	2.70 x 10 <sup>-2</sup>	1.26 x 10 <sup>-1</sup>	2.70 x 10 <sup>-2</sup>	1.34 x 10 <sup>-1</sup>
TRH15FE	1.01 x 10 <sup>-1</sup>	2.19 x 10 <sup>-2</sup>	1.01 x 10 <sup>-1</sup>	2.19 x 10 <sup>-2</sup>	1.34 x 10 <sup>-1</sup>
TRH20FN	1.11 x 10 <sup>-1</sup>	2.35 x 10 <sup>-2</sup>	1.11 x 10 <sup>-1</sup>	2.35 x 10 <sup>-2</sup>	9.90 x 10 <sup>-2</sup>
TRH20FL	1.05 x 10 <sup>-1</sup>	2.20 x 10 <sup>-2</sup>	1.05 x 10 <sup>-1</sup>	2.20 x 10 <sup>-2</sup>	9.90 x 10 <sup>-2</sup>
TRH20FE	8.00 x 10 <sup>-2</sup>	1.78 x 10 <sup>-2</sup>	8.00 x 10 <sup>-2</sup>	1.78 x 10 <sup>-2</sup>	9.90 x 10 <sup>-2</sup>
TRH25FN	1.04 x 10 <sup>-1</sup>	2.17 x 10 <sup>-2</sup>	1.04 x 10 <sup>-1</sup>	2.17 x 10 <sup>-2</sup>	8.62 x 10 <sup>-2</sup>
TRH25FL	8.82 x 10 <sup>-2</sup>	1.89 x 10 <sup>-2</sup>	8.82 x 10 <sup>-2</sup>	1.89 x 10 <sup>-2</sup>	8.62 x 10 <sup>-2</sup>
TRH25FE	7.35 x 10 <sup>-2</sup>	1.60 x 10 <sup>-2</sup>	7.35 x 10 <sup>-2</sup>	1.60 x 10 <sup>-2</sup>	8.62 x 10 <sup>-2</sup>
TRH30FL	7.74 x 10 <sup>-2</sup>	1.64 x 10 <sup>-2</sup>	7.74 x 10 <sup>-2</sup>	1.64 x 10 <sup>-2</sup>	7.15 x 10 <sup>-2</sup>
TRH30FE	6.12 x 10 <sup>-2</sup>	1.33 x 10 <sup>-2</sup>	6.12 x 10 <sup>-2</sup>	1.33 x 10 <sup>-2</sup>	7.15 x 10 <sup>-2</sup>
TRH35FL	6.99 x 10 <sup>-2</sup>	1.42 x 10 <sup>-2</sup>	6.99 x 10 <sup>-2</sup>	1.42 x 10 <sup>-2</sup>	5.85 x 10 <sup>-2</sup>
TRH35FE	5.25 x 10 <sup>-2</sup>	1.15 x 10 <sup>-2</sup>	5.25 x 10 <sup>-2</sup>	1.15 x 10 <sup>-2</sup>	5.85 x 10 <sup>-2</sup>
TRH45FL	5.80 x 10 <sup>-2</sup>	1.24 x 10 <sup>-2</sup>	5.80 x 10 <sup>-2</sup>	1.24 x 10 <sup>-2</sup>	4.38 x 10 <sup>-2</sup>
TRH45FE	4.59 x 10 <sup>-2</sup>	1.00 x 10 <sup>-2</sup>	4.59 x 10 <sup>-2</sup>	1.00 x 10 <sup>-2</sup>	4.38 x 10 <sup>-2</sup>
TRH55FL	5.25 x 10 <sup>-2</sup>	1.07 x 10 <sup>-2</sup>	5.25 x 10 <sup>-2</sup>	1.07 x 10 <sup>-2</sup>	3.78 x 10 <sup>-2</sup>
TRH55FE	4.08 x 10 <sup>-2</sup>	8.69 x 10 <sup>-3</sup>	4.08 x 10 <sup>-2</sup>	8.69 x 10 <sup>-3</sup>	3.78 x 10 <sup>-2</sup>
TRH65FL	4.52 x 10 <sup>-2</sup>	8.76 x 10 <sup>-3</sup>	4.52 x 10 <sup>-2</sup>	8.76 x 10 <sup>-3</sup>	3.24 x 10 <sup>-2</sup>
TRH65FE	3.27 x 10 <sup>-2</sup>	6.77 x 10 <sup>-3</sup>	3.27 x 10 <sup>-2</sup>	6.77 x 10 <sup>-3</sup>	3.24 x 10 <sup>-2</sup>

Ka : Equivalent moment factor in the pitching direction.

Kb : Equivalent moment factor in the yawing direction.

Kc : Equivalent moment factor in the rolling direction.

Table1.5.2 TRH-V

Model No.	Equivalent Factors Ka (mm <sup>-1</sup> )		Equivalent Factors Kb (mm <sup>-1</sup> )		Equivalent Factors Kc (mm <sup>-1</sup> )
	Equivalent Load Calculation for a system Using One Linear Guide Block	Equivalent Load Calculation for a system Using Two Linear Guide Blocks laid Over One-Another	Equivalent Load Calculation for a system Using One Linear Guide Block	Equivalent Load Calculation for a system Using Two Linear Guide Blocks laid Over One-Another	
TRH15VN	1.48 x 10 <sup>-1</sup>	3.11 x 10 <sup>-2</sup>	1.48 x 10 <sup>-1</sup>	3.11 x 10 <sup>-2</sup>	1.34 x 10 <sup>-1</sup>
TRH15VL	1.26 x 10 <sup>-1</sup>	2.70 x 10 <sup>-2</sup>	1.26 x 10 <sup>-1</sup>	2.70 x 10 <sup>-2</sup>	1.34 x 10 <sup>-1</sup>
TRH20VN	1.11 x 10 <sup>-1</sup>	2.35 x 10 <sup>-2</sup>	1.11 x 10 <sup>-1</sup>	2.35 x 10 <sup>-2</sup>	9.90 x 10 <sup>-2</sup>
TRH20VL	1.05 x 10 <sup>-1</sup>	2.20 x 10 <sup>-2</sup>	1.05 x 10 <sup>-1</sup>	2.20 x 10 <sup>-2</sup>	9.90 x 10 <sup>-2</sup>
TRH20VE	8.00 x 10 <sup>-2</sup>	1.78 x 10 <sup>-2</sup>	8.00 x 10 <sup>-2</sup>	1.78 x 10 <sup>-2</sup>	9.90 x 10 <sup>-2</sup>
TRH25VN	1.04 x 10 <sup>-1</sup>	2.17 x 10 <sup>-2</sup>	1.04 x 10 <sup>-1</sup>	2.17 x 10 <sup>-2</sup>	8.62 x 10 <sup>-2</sup>
TRH25VL	8.82 x 10 <sup>-2</sup>	1.89 x 10 <sup>-2</sup>	8.82 x 10 <sup>-2</sup>	1.89 x 10 <sup>-2</sup>	8.62 x 10 <sup>-2</sup>
TRH25VE	7.35 x 10 <sup>-2</sup>	1.60 x 10 <sup>-2</sup>	7.35 x 10 <sup>-2</sup>	1.60 x 10 <sup>-2</sup>	8.62 x 10 <sup>-2</sup>
TRH30VL	7.74 x 10 <sup>-2</sup>	1.64 x 10 <sup>-2</sup>	7.74 x 10 <sup>-2</sup>	1.64 x 10 <sup>-2</sup>	7.15 x 10 <sup>-2</sup>
TRH30VE	6.12 x 10 <sup>-2</sup>	1.33 x 10 <sup>-2</sup>	6.12 x 10 <sup>-2</sup>	1.33 x 10 <sup>-2</sup>	7.15 x 10 <sup>-2</sup>
TRH35VL	6.99 x 10 <sup>-2</sup>	1.42 x 10 <sup>-2</sup>	6.99 x 10 <sup>-2</sup>	1.42 x 10 <sup>-2</sup>	5.85 x 10 <sup>-2</sup>
TRH35VE	5.25 x 10 <sup>-2</sup>	1.15 x 10 <sup>-2</sup>	5.25 x 10 <sup>-2</sup>	1.15 x 10 <sup>-2</sup>	5.85 x 10 <sup>-2</sup>
TRH45VL	5.80 x 10 <sup>-2</sup>	1.24 x 10 <sup>-2</sup>	5.80 x 10 <sup>-2</sup>	1.24 x 10 <sup>-2</sup>	4.38 x 10 <sup>-2</sup>
TRH45VE	4.59 x 10 <sup>-2</sup>	1.00 x 10 <sup>-2</sup>	4.59 x 10 <sup>-2</sup>	1.00 x 10 <sup>-2</sup>	4.38 x 10 <sup>-2</sup>
TRH55VL	5.25 x 10 <sup>-2</sup>	1.07 x 10 <sup>-2</sup>	5.25 x 10 <sup>-2</sup>	1.07 x 10 <sup>-2</sup>	3.78 x 10 <sup>-2</sup>
TRH55VE	4.08 x 10 <sup>-2</sup>	8.69 x 10 <sup>-3</sup>	4.08 x 10 <sup>-2</sup>	8.69 x 10 <sup>-3</sup>	3.78 x 10 <sup>-2</sup>
TRH65VL	4.52 x 10 <sup>-2</sup>	8.76 x 10 <sup>-3</sup>	4.52 x 10 <sup>-2</sup>	8.76 x 10 <sup>-3</sup>	3.24 x 10 <sup>-2</sup>
TRH65VE	3.27 x 10 <sup>-2</sup>	6.77 x 10 <sup>-3</sup>	3.27 x 10 <sup>-2</sup>	6.77 x 10 <sup>-3</sup>	3.24 x 10 <sup>-2</sup>

Ka : Equivalent moment factor in the pitching direction.

Kb : Equivalent moment factor in the yawing direction.

Kc : Equivalent moment factor in the rolling direction.



Table1.5.3 TRS-F

Model No.	Equivalent Factors Ka (mm <sup>-1</sup> )		Equivalent Factors Kb (mm <sup>-1</sup> )		Equivalent Factors Kc (mm <sup>-1</sup> )
	Equivalent Load Calculation for a system Using One Linear Guide Block	Equivalent Load Calculation for a system Using Two Linear Guide Blocks laid Over One-Another	Equivalent Load Calculation for a system Using One Linear Guide Block	Equivalent Load Calculation for a system Using Two Linear Guide Blocks laid Over One-Another	
TRS15FS	2.29 x 10 <sup>-1</sup>	4.39 x 10 <sup>-2</sup>	2.29 x 10 <sup>-1</sup>	4.39 x 10 <sup>-2</sup>	1.34 x 10 <sup>-1</sup>
TRS15FN	1.48 x 10 <sup>-1</sup>	3.11 x 10 <sup>-2</sup>	1.48 x 10 <sup>-1</sup>	3.11 x 10 <sup>-2</sup>	1.34 x 10 <sup>-1</sup>
TRS20FS	2.00 x 10 <sup>-1</sup>	3.58 x 10 <sup>-2</sup>	2.00 x 10 <sup>-1</sup>	3.58 x 10 <sup>-2</sup>	9.90 x 10 <sup>-2</sup>
TRS20FN	1.25 x 10 <sup>-1</sup>	2.60 x 10 <sup>-2</sup>	1.25 x 10 <sup>-1</sup>	2.60 x 10 <sup>-2</sup>	9.90 x 10 <sup>-2</sup>
TRS25FS	1.60 x 10 <sup>-1</sup>	3.07 x 10 <sup>-2</sup>	1.60 x 10 <sup>-1</sup>	3.07 x 10 <sup>-2</sup>	8.62 x 10 <sup>-2</sup>
TRS25FN	1.04 x 10 <sup>-1</sup>	2.17 x 10 <sup>-2</sup>	1.04 x 10 <sup>-1</sup>	2.17 x 10 <sup>-2</sup>	8.62 x 10 <sup>-2</sup>
TRS30FS	1.47 x 10 <sup>-1</sup>	2.57 x 10 <sup>-2</sup>	1.47 x 10 <sup>-1</sup>	2.57 x 10 <sup>-2</sup>	7.15 x 10 <sup>-2</sup>
TRS30FN	8.65 x 10 <sup>-2</sup>	1.82 x 10 <sup>-2</sup>	8.65 x 10 <sup>-2</sup>	1.82 x 10 <sup>-2</sup>	7.15 x 10 <sup>-2</sup>
TRS35FS	1.26 x 10 <sup>-1</sup>	2.30 x 10 <sup>-2</sup>	1.26 x 10 <sup>-1</sup>	2.30 x 10 <sup>-2</sup>	5.85 x 10 <sup>-2</sup>
TRS35FN	7.87 x 10 <sup>-2</sup>	1.61 x 10 <sup>-2</sup>	7.87 x 10 <sup>-2</sup>	1.61 x 10 <sup>-2</sup>	5.85 x 10 <sup>-2</sup>
TRS45FN	6.89 x 10 <sup>-2</sup>	1.39 x 10 <sup>-2</sup>	6.89 x 10 <sup>-2</sup>	1.39 x 10 <sup>-2</sup>	4.38 x 10 <sup>-2</sup>

Ka : Equivalent moment factor in the pitching direction.

Kb : Equivalent moment factor in the yawing direction.

Kc : Equivalent moment factor in the rolling direction.

Table1.5.4 TRS-V

Model No.	Equivalent Factors Ka (mm <sup>-1</sup> )		Equivalent Factors Kb (mm <sup>-1</sup> )		Equivalent Factors Kc (mm <sup>-1</sup> )
	Equivalent Load Calculation for a system Using One Linear Guide Block	Equivalent Load Calculation for a system Using Two Linear Guide Blocks laid Over One-Another	Equivalent Load Calculation for a system Using One Linear Guide Block	Equivalent Load Calculation for a system Using Two Linear Guide Blocks laid Over One-Another	
TRS15VS	2.29 x 10 <sup>-1</sup>	4.39 x 10 <sup>-2</sup>	2.29 x 10 <sup>-1</sup>	4.39 x 10 <sup>-2</sup>	1.34 x 10 <sup>-1</sup>
TRS15VN	1.48 x 10 <sup>-1</sup>	3.11 x 10 <sup>-2</sup>	1.48 x 10 <sup>-1</sup>	3.11 x 10 <sup>-2</sup>	1.34 x 10 <sup>-1</sup>
TRS15VL	1.26 x 10 <sup>-1</sup>	2.70 x 10 <sup>-2</sup>	1.26 x 10 <sup>-1</sup>	2.70 x 10 <sup>-2</sup>	1.34 x 10 <sup>-1</sup>
TRS15VE	1.01 x 10 <sup>-1</sup>	2.19 x 10 <sup>-2</sup>	1.01 x 10 <sup>-1</sup>	2.19 x 10 <sup>-2</sup>	1.34 x 10 <sup>-1</sup>
TRS20VS	2.00 x 10 <sup>-1</sup>	3.58 x 10 <sup>-2</sup>	2.00 x 10 <sup>-1</sup>	3.58 x 10 <sup>-2</sup>	9.90 x 10 <sup>-2</sup>
TRS20VN	1.25 x 10 <sup>-1</sup>	2.60 x 10 <sup>-2</sup>	1.25 x 10 <sup>-1</sup>	2.60 x 10 <sup>-2</sup>	9.90 x 10 <sup>-2</sup>
TRS25VS	1.60 x 10 <sup>-1</sup>	3.07 x 10 <sup>-2</sup>	1.60 x 10 <sup>-1</sup>	3.07 x 10 <sup>-2</sup>	8.62 x 10 <sup>-2</sup>
TRS25VN	1.04 x 10 <sup>-1</sup>	2.17 x 10 <sup>-2</sup>	1.04 x 10 <sup>-1</sup>	2.17 x 10 <sup>-2</sup>	8.62 x 10 <sup>-2</sup>
TRS30VS	1.47 x 10 <sup>-1</sup>	2.57 x 10 <sup>-2</sup>	1.47 x 10 <sup>-1</sup>	2.57 x 10 <sup>-2</sup>	7.15 x 10 <sup>-2</sup>
TRS30VN	8.65 x 10 <sup>-2</sup>	1.82 x 10 <sup>-2</sup>	8.65 x 10 <sup>-2</sup>	1.82 x 10 <sup>-2</sup>	7.15 x 10 <sup>-2</sup>
TRS30VL	7.74 x 10 <sup>-2</sup>	1.64 x 10 <sup>-2</sup>	7.74 x 10 <sup>-2</sup>	1.64 x 10 <sup>-2</sup>	7.15 x 10 <sup>-2</sup>
TRS30VE	6.12 x 10 <sup>-2</sup>	1.33 x 10 <sup>-2</sup>	6.12 x 10 <sup>-2</sup>	1.33 x 10 <sup>-2</sup>	7.15 x 10 <sup>-2</sup>
TRS35VS	1.26 x 10 <sup>-1</sup>	2.30 x 10 <sup>-2</sup>	1.26 x 10 <sup>-1</sup>	2.30 x 10 <sup>-2</sup>	5.85 x 10 <sup>-2</sup>
TRS35VN	7.87 x 10 <sup>-2</sup>	1.61 x 10 <sup>-2</sup>	7.87 x 10 <sup>-2</sup>	1.61 x 10 <sup>-2</sup>	5.85 x 10 <sup>-2</sup>
TRS35VL	6.99 x 10 <sup>-2</sup>	1.42 x 10 <sup>-2</sup>	6.99 x 10 <sup>-2</sup>	1.42 x 10 <sup>-2</sup>	5.85 x 10 <sup>-2</sup>
TRS35VE	5.25 x 10 <sup>-2</sup>	1.15 x 10 <sup>-2</sup>	5.25 x 10 <sup>-2</sup>	1.15 x 10 <sup>-2</sup>	5.85 x 10 <sup>-2</sup>
TRS45VN	6.89 x 10 <sup>-2</sup>	1.39 x 10 <sup>-2</sup>	6.89 x 10 <sup>-2</sup>	1.39 x 10 <sup>-2</sup>	4.38 x 10 <sup>-2</sup>
TRS45VL	5.80 x 10 <sup>-2</sup>	1.24 x 10 <sup>-2</sup>	5.80 x 10 <sup>-2</sup>	1.24 x 10 <sup>-2</sup>	4.38 x 10 <sup>-2</sup>
TRS45VE	4.59 x 10 <sup>-2</sup>	1.00 x 10 <sup>-2</sup>	4.59 x 10 <sup>-2</sup>	1.00 x 10 <sup>-2</sup>	4.38 x 10 <sup>-2</sup>

Ka : Equivalent moment factor in the pitching direction.

Kb : Equivalent moment factor in the yawing direction.

Kc : Equivalent moment factor in the rolling direction.

Table1.5.5 TRC-V

Model No.	Equivalent Factors Ka ( $\text{mm}^{-1}$ )		Equivalent Factors Kb ( $\text{mm}^{-1}$ )		Equivalent Factors Kc ( $\text{mm}^{-1}$ )
	Equivalent Load Calculation for a system Using One Linear Guide Block	Equivalent Load Calculation for a system Using Two Linear Guide Blocks laid Over One-Another	Equivalent Load Calculation for a system Using One Linear Guide Block	Equivalent Load Calculation for a system Using Two Linear Guide Blocks laid Over One-Another	
TRC25VL	$8.82 \times 10^{-2}$	$1.89 \times 10^{-2}$	$8.82 \times 10^{-2}$	$1.89 \times 10^{-2}$	$8.62 \times 10^{-2}$
TRC25VE	$7.35 \times 10^{-2}$	$1.60 \times 10^{-2}$	$7.35 \times 10^{-2}$	$1.60 \times 10^{-2}$	$8.62 \times 10^{-2}$

Ka : Equivalent moment factor in the pitching direction.

Kb : Equivalent moment factor in the yawing direction.

Kc : Equivalent moment factor in the rolling direction.

表1.5.6 TM-N

Model No.	Equivalent Factors Ka ( $\text{mm}^{-1}$ )		Equivalent Factors Kb ( $\text{mm}^{-1}$ )		Equivalent Factors Kc ( $\text{mm}^{-1}$ )
	Equivalent Load Calculation for a system Using One Linear Guide Block	Equivalent Load Calculation for a system Using Two Linear Guide Blocks laid Over One-Another	Equivalent Load Calculation for a system Using One Linear Guide Block	Equivalent Load Calculation for a system Using Two Linear Guide Blocks laid Over One-Another	
TM07NN	$8.82 \times 10^{-1}$	$6.31 \times 10^{-2}$	$8.82 \times 10^{-1}$	$6.31 \times 10^{-2}$	$2.74 \times 10^{-1}$
TM07NL	$4.41 \times 10^{-1}$	$5.16 \times 10^{-2}$	$4.41 \times 10^{-1}$	$5.16 \times 10^{-2}$	$2.74 \times 10^{-1}$
TM09NN	$4.41 \times 10^{-1}$	$5.26 \times 10^{-2}$	$4.41 \times 10^{-1}$	$5.26 \times 10^{-2}$	$2.19 \times 10^{-1}$
TM09NL	$2.76 \times 10^{-1}$	$4.08 \times 10^{-2}$	$2.76 \times 10^{-1}$	$4.08 \times 10^{-2}$	$2.19 \times 10^{-1}$
TM12NN	$4.90 \times 10^{-1}$	$4.32 \times 10^{-2}$	$4.90 \times 10^{-1}$	$4.32 \times 10^{-2}$	$1.64 \times 10^{-1}$
TM12NL	$2.67 \times 10^{-1}$	$3.42 \times 10^{-2}$	$2.67 \times 10^{-1}$	$3.42 \times 10^{-2}$	$1.64 \times 10^{-1}$
TM15NN	$3.60 \times 10^{-1}$	$3.61 \times 10^{-2}$	$3.60 \times 10^{-1}$	$3.61 \times 10^{-2}$	$1.32 \times 10^{-1}$
TM15NL	$1.94 \times 10^{-1}$	$2.76 \times 10^{-2}$	$1.94 \times 10^{-1}$	$2.76 \times 10^{-2}$	$1.32 \times 10^{-1}$

Ka : Equivalent moment factor in the pitching direction.

Kb : Equivalent moment factor in the yawing direction.

Kc : Equivalent moment factor in the rolling direction.

## 1-5-2 Calculating the Equivalent Load

The Linear Guide can bear loads and moments in four directions, including a radial load (PR), reverse-radial load (PL), and lateral load (PT), simultaneously.

- PR : Radial load
- PL : Reverse-radial load
- PT : Lateral load
- MA : Moment in the pitching direction
- MB : Moment in the yawing direction
- MC : Moment in the rolling direction

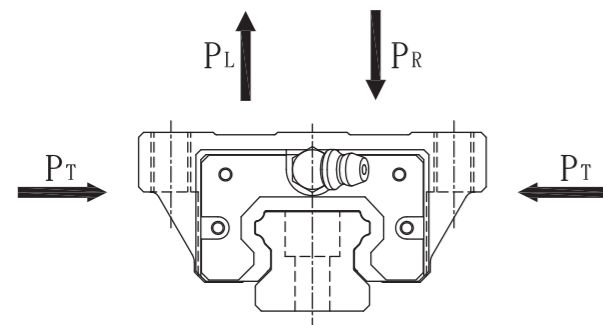

Fig1.5.4 Directions of the Load and Moment Exerted on the Linear Guide

### Equivalent load PE

When more than one load (e.g., radial and lateral loads) is exerted on the Linear Guide simultaneously, the service life and static safety factors should be calculated using equivalent load values obtained by converting all loads involved into radial, lateral, and other loads involved.

### Equivalent-load equation

The equivalent-load equations for the Linear Guide differ by guide type. For details, see the relevant sections.

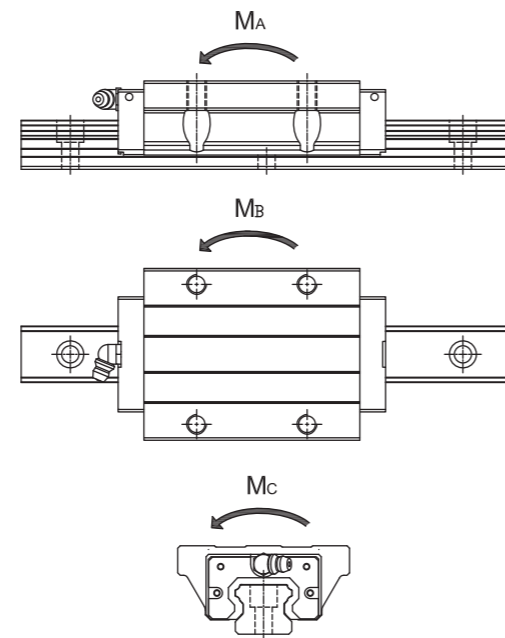

Fig1.5.3

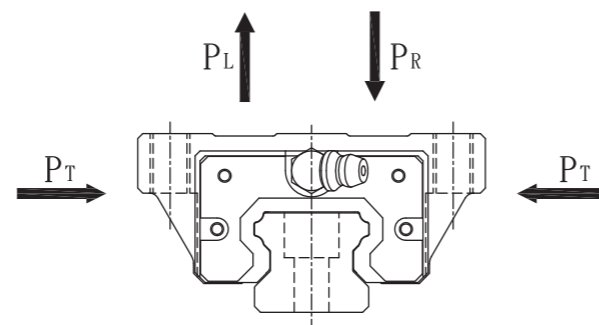

Fig1.5.5 Linear Guide Equivalent load

The equivalent load when a radial load (PR) and a lateral load (PT) are applied simultaneously can be obtained using the following equation.

$$PE : (\text{equivalent load}) = PR + PT$$

- PR : Radial load
- PT : Lateral load

## 1-6 Calculation of average working load

### 1-6-1 Calculating the Mean Load

An industrial robot grasps a workpiece using its arm as it advances, moving further under the load. When it returns, the arm has no load other than its tare. In a machine tool, Linear Guide blocks receive varying loads depending on the host-system operating conditions.

The service life of the Linear Guides; therefore, should be calculated in consideration of such fluctuations in load.

The mean load (Pm) is the load under which the service life of the Linear Guide becomes equivalent to that under the varying loads exerted on the Linear Guide blocks.

$$P_m = \sqrt[3]{\frac{1}{L} \cdot \sum (P_n^3 \cdot L_n)}$$

- Pm : mean load (N)
  - Pn : varying load (N)
  - Lc : total running distance (mm)
  - Ln : running distance under load Pn (mm)
- Note : This equation and equation (1) below apply in cases in which the rolling elements are balls.

$$P_m = \sqrt[3]{\frac{1}{L} (P_1^3 \cdot L_1 + P_2^3 \cdot L_2 + \dots + P_n^3 \cdot L_n)} \dots \dots (1)$$

- Pm : mean load (N)
- Pn : varying load (N)
- Lc : total running distance (mm)
- Ln : running distance under load Pn (mm)

(1) For loads that change stepwise

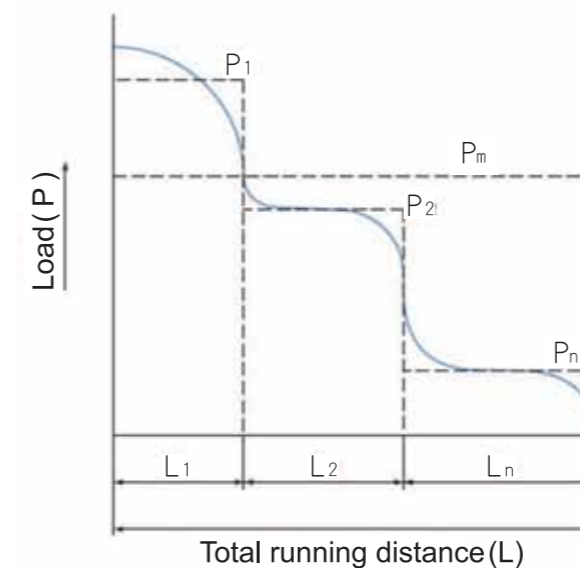

Fig1.5.6

(2) For loads that change monotonous

$$P_m \cong \frac{1}{3} (P_{min} + 2 \cdot P_{max}) \dots\dots(2)$$

P min : minimum load (N)

P max : maximum load (N)

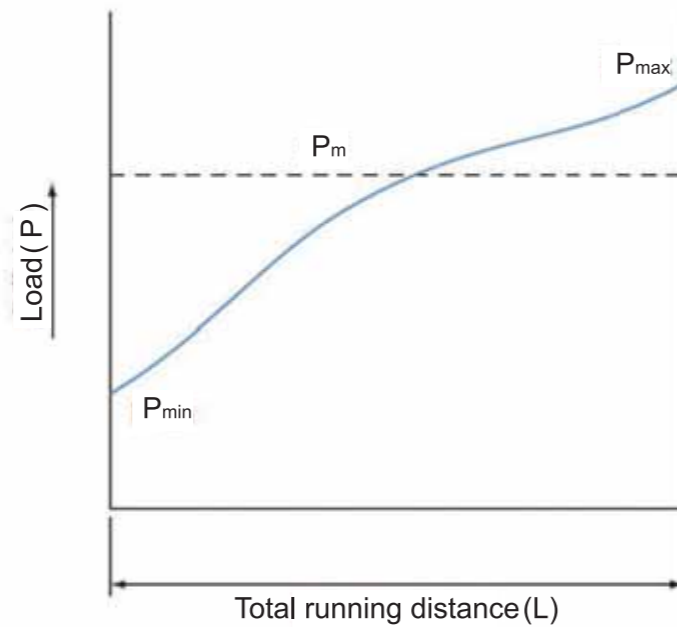

Fig.1.5.7

(3) For loads that change sinusoidal

$$P_m \cong 0.65 P_{max} \dots\dots\dots(3)$$

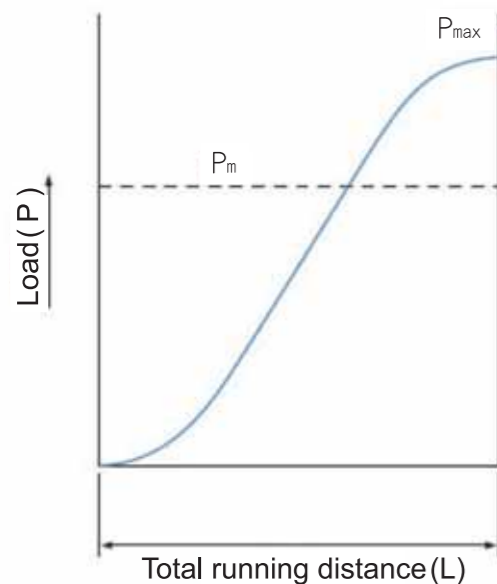

Fig.1.5.8

$$P_m \cong 0.75 P_{max} \dots\dots\dots(4)$$

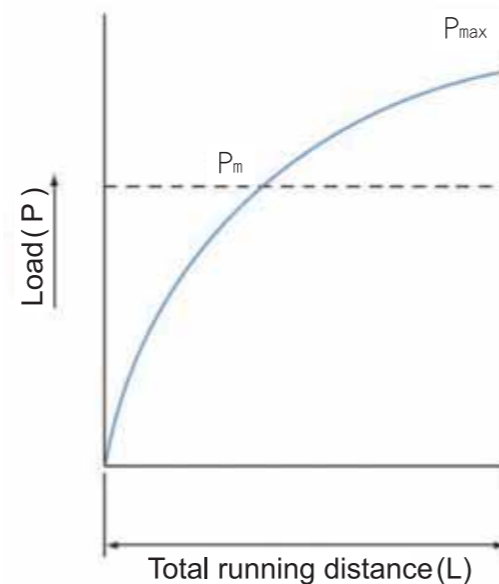
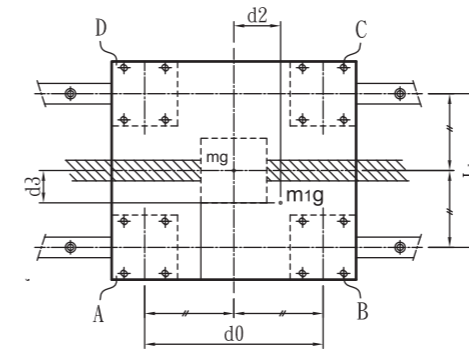

Fig.1.5.9

## 1-6-2 Mean Load Calculation Example ( I )

(1) Horizontal Installations Subjected to Acceleration and Deceleration



$$\alpha_1 = \frac{V}{t_1} \text{ m/s}^2$$

Fig1.6.1

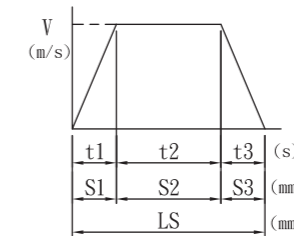

Fig1.6.2

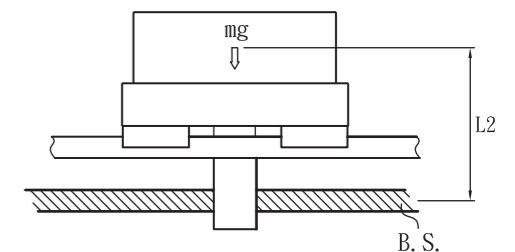

Fig1.6.3

(2) Load applied to the Linear Guide block

1. In uniform motion

$$P_1 = + \frac{mg}{4}$$

$$P_2 = + \frac{mg}{4}$$

$$P_3 = + \frac{mg}{4}$$

$$P_4 = + \frac{mg}{4}$$

2. During acceleration

$$P_{a_1} = P_1 + \frac{m \cdot \alpha_1 \cdot L_2}{2 \cdot L_0}$$

$$P_{a_2} = P_2 + \frac{m \cdot \alpha_1 \cdot L_2}{2 \cdot L_0}$$

$$P_{a_3} = P_3 + \frac{m \cdot \alpha_1 \cdot L_2}{2 \cdot L_0}$$

$$P_{a_4} = P_4 + \frac{m \cdot \alpha_1 \cdot L_2}{2 \cdot L_0}$$

3. During deceleration

$$P_{d_1} = P_1 - \frac{m \cdot \alpha_1 \cdot L_2}{2 \cdot L_0}$$

$$P_{d_2} = P_2 + \frac{m \cdot \alpha_1 \cdot L_2}{2 \cdot L_0}$$

$$P_{d_3} = P_3 + \frac{m \cdot \alpha_1 \cdot L_2}{2 \cdot L_0}$$

$$P_{d_4} = P_4 + \frac{m \cdot \alpha_1 \cdot L_2}{2 \cdot L_0}$$

(3) Mean load

$$P_{m_1} = \sqrt[3]{\frac{1}{L_s} ( P_{a_1}^3 \cdot S_1 + P_1^3 \cdot S_2 + P_{d_1}^3 \cdot S_3 )}$$

$$P_{m_3} = \sqrt[3]{\frac{1}{L_s} ( P_{a_3}^3 \cdot S_1 + P_3^3 \cdot S_2 + P_{d_3}^3 \cdot S_3 )}$$

$$P_{m_2} = \sqrt[3]{\frac{1}{L_s} ( P_{a_2}^3 \cdot S_1 + P_2^3 \cdot S_2 + P_{d_2}^3 \cdot S_3 )}$$

$$P_{m_4} = \sqrt[3]{\frac{1}{L_s} ( P_{a_4}^3 \cdot S_1 + P_4^3 \cdot S_2 + P_{d_4}^3 \cdot S_3 )}$$

Note:  $P_{a_n}$  ·  $P_{d_n}$  represent loads exerted on the Linear Guide block. The suffix “n” indicates the block number in the diagram above.



## Mean Load Calculation Example (II)

(1) Operating conditions-Installations on Rails.

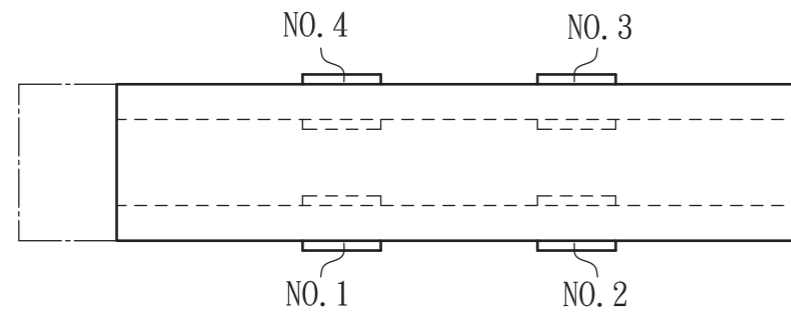

Fig.1.6.4

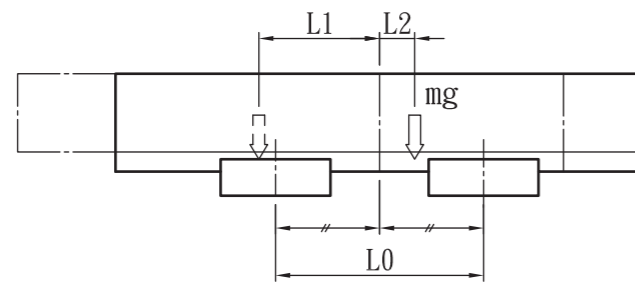

Fig.1.6.5

(2) Load applied to the Linear Guide block

1. At the left of the arm

$$P_{L1} = + \frac{mg}{4} + \frac{mg \cdot L_1}{2 \cdot L_0}$$

$$P_{L2} = + \frac{mg}{4} - \frac{mg \cdot L_1}{2 \cdot L_0}$$

$$P_{L3} = + \frac{mg}{4} - \frac{mg \cdot L_1}{2 \cdot L_0}$$

$$P_{L4} = + \frac{mg}{4} + \frac{mg \cdot L_1}{2 \cdot L_0}$$

2. At the right of the arm

$$P_{R1} = + \frac{mg}{4} - \frac{mg \cdot L_1}{2 \cdot L_0}$$

$$P_{R2} = + \frac{mg}{4} + \frac{mg \cdot L_1}{2 \cdot L_0}$$

$$P_{R3} = + \frac{mg}{4} + \frac{mg \cdot L_1}{2 \cdot L_0}$$

$$P_{R4} = + \frac{mg}{4} - \frac{mg \cdot L_1}{2 \cdot L_0}$$

(3) Mean load

$$P_{m1} = \frac{1}{3} (2 \cdot |P_{L1}| + |P_{R1}|)$$

$$P_{m1} = \frac{1}{3} (2 \cdot |P_{L2}| + |P_{R2}|)$$

$$P_{m1} = \frac{1}{3} (2 \cdot |P_{L3}| + |P_{R3}|)$$

$$P_{m1} = \frac{1}{3} (2 \cdot |P_{L4}| + |P_{R4}|)$$

Note:  $P_{Ln}$  ·  $P_{m}$  represent loads exerted on the Linear Guide block. The suffix “n” indicates the block number in the diagram above.

## 1-7 Calculation example

### 1-7-1 Calculation Examples

#### Example 1

(1) Operating conditions-Horizontal installations subjected to high acceleration and deceleration

Model number : TRH30FE

Basic dynamic-load rating C = 47kN

Basic static-load rating C0 = 88.329kN

Gravitational acceleration : g = 9.8 (m/s<sup>2</sup>)

Load : m1 = 6000N

m2 = 3800N

Velocity : V = 0.5 m/s

Time : t1 = 0.05s

t2 = 2.8s

t3 = 0.15s

Acceleration : α1 = 10 m/s<sup>2</sup>

α2 = 3.333 m/s<sup>2</sup>

Stroke : Ls = 1450 mm

Distance : L0 = 600 mm

L1 = 400 mm

L2 = 100 mm

L3 = 50 mm

L4 = 200 mm

L5 = 400 mm

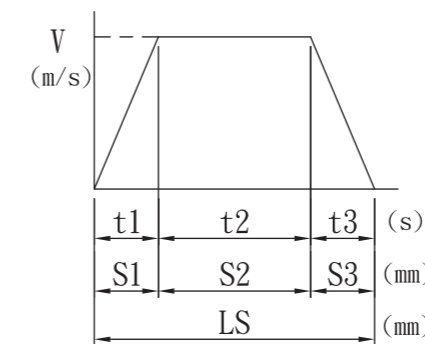

Fig.1.7.1

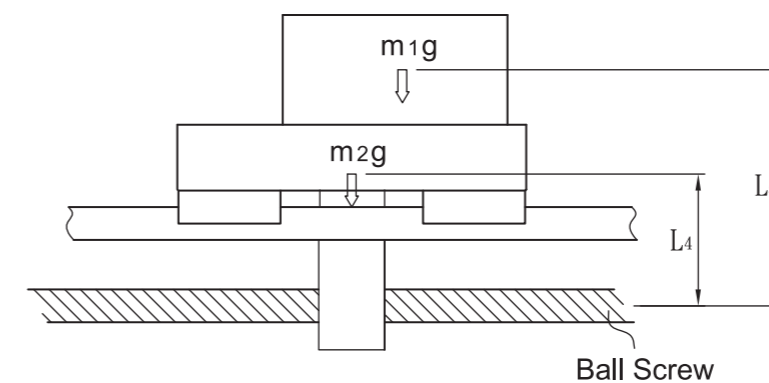

Fig.1.7.3

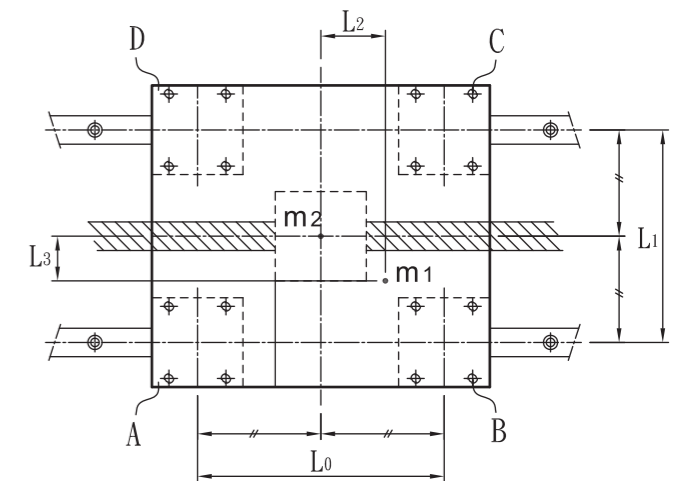

Fig.1.7.2

## (2) Load Exerted on the Linear Guide by the Linear Guide Block

Calculate the load that each Linear Guide block exerts.

1. In uniform motion Load applied in radial direction  $P_n$ . (Base on the first condition of Load exerted [ please see page14, No.1 ] , that's regarding influence of  $m_1g$  and  $m_2g$ .)

$$P_A = \frac{m_1g}{4} - \frac{m_1g \cdot L_2}{2 \cdot L_0} + \frac{m_1g \cdot L_3}{2 \cdot L_1} + \frac{m_2g}{4} = 2325 \text{ N} \quad P_C = \frac{m_1g}{4} + \frac{m_1g \cdot L_2}{2 \cdot L_0} - \frac{m_1g \cdot L_3}{2 \cdot L_1} + \frac{m_2g}{4} = 2575 \text{ N}$$

$$P_B = \frac{m_1g}{4} + \frac{m_1g \cdot L_2}{2 \cdot L_0} + \frac{m_1g \cdot L_3}{2 \cdot L_1} + \frac{m_2g}{4} = 3325 \text{ N} \quad P_D = \frac{m_1g}{4} - \frac{m_1g \cdot L_2}{2 \cdot L_0} - \frac{m_1g \cdot L_3}{2 \cdot L_1} + \frac{m_2g}{4} = 1575 \text{ N}$$

2. During acceleration to the left Load applied in radial direction  $P_{nLa}$  and lateral direction  $P_{ntLa}$  (Base on the 8th condition of load exerted [ please see page 17. No.8 ]. The load should allocate on the central of table, and  $\frac{m_1g}{4}$  should be re-placed by  $P_n$ ).

$$P_{ALa} = P_A - \frac{m_1g \cdot \alpha_1 \cdot L_5}{2 \cdot L_0 \cdot g} - \frac{m_2g \cdot \alpha_1 \cdot L_4}{2 \cdot L_0 \cdot g} = -362 \text{ N} \quad P_{CLa} = P_C - \frac{m_1g \cdot \alpha_1 \cdot L_5}{2 \cdot L_0 \cdot g} - \frac{m_2g \cdot \alpha_1 \cdot L_4}{2 \cdot L_0 \cdot g} = 5262.1 \text{ N}$$

$$P_{BLa} = P_B - \frac{m_1g \cdot \alpha_1 \cdot L_5}{2 \cdot L_0 \cdot g} - \frac{m_2g \cdot \alpha_1 \cdot L_4}{2 \cdot L_0 \cdot g} = 6012.1 \text{ N} \quad P_{DLa} = P_D - \frac{m_1g \cdot \alpha_1 \cdot L_5}{2 \cdot L_0 \cdot g} - \frac{m_2g \cdot \alpha_1 \cdot L_4}{2 \cdot L_0 \cdot g} = 1112.1 \text{ N}$$

$$P_{AtLa} = -\frac{m_1g \cdot \alpha_1 \cdot L_3}{2 \cdot L_0 \cdot g} = -255.1 \text{ N} \quad P_{CtLa} = -\frac{m_1g \cdot \alpha_1 \cdot L_3}{2 \cdot L_0 \cdot g} = 255.1 \text{ N}$$

$$P_{BtLa} = -\frac{m_1g \cdot \alpha_1 \cdot L_3}{2 \cdot L_0 \cdot g} = 255.1 \text{ N} \quad P_{DtLa} = -\frac{m_1g \cdot \alpha_1 \cdot L_3}{2 \cdot L_0 \cdot g} = -255.1 \text{ N}$$

3. During deceleration to the left Load applied in radial direction  $P_{nLd}$

$$P_{ALd} = P_A + \frac{m_1g \cdot \alpha_3 \cdot L_5}{2 \cdot L_0 \cdot g} + \frac{m_2g \cdot \alpha_3 \cdot L_4}{2 \cdot L_0 \cdot g} = 3220.6 \text{ N} \quad P_{CLd} = P_C - \frac{m_1g \cdot \alpha_3 \cdot L_5}{2 \cdot L_0 \cdot g} - \frac{m_2g \cdot \alpha_3 \cdot L_4}{2 \cdot L_0 \cdot g} = 1679.4 \text{ N}$$

$$P_{BLd} = P_B - \frac{m_1g \cdot \alpha_3 \cdot L_5}{2 \cdot L_0 \cdot g} - \frac{m_2g \cdot \alpha_3 \cdot L_4}{2 \cdot L_0 \cdot g} = 2429.4 \text{ N} \quad P_{DLd} = P_D + \frac{m_1g \cdot \alpha_3 \cdot L_5}{2 \cdot L_0 \cdot g} + \frac{m_2g \cdot \alpha_3 \cdot L_4}{2 \cdot L_0 \cdot g} = 2470.6 \text{ N}$$

Load applied in lateral direction  $P_{ntLd}$

$$P_{AtLd} = \frac{m_1g \cdot \alpha_3 \cdot L_3}{2 \cdot L_0 \cdot g} = 85 \text{ N} \quad P_{CtLd} = -\frac{m_1g \cdot \alpha_3 \cdot L_3}{2 \cdot L_0 \cdot g} = -85 \text{ N}$$

$$P_{BtLd} = -\frac{m_1g \cdot \alpha_3 \cdot L_3}{2 \cdot L_0 \cdot g} = -85 \text{ N} \quad P_{DtLd} = \frac{m_1g \cdot \alpha_3 \cdot L_3}{2 \cdot L_0 \cdot g} = 85 \text{ N}$$

4. During acceleration to the right Load applied in radial direction  $P_{nRa}$

$$P_{ARa} = P_A + \frac{m_1g \cdot \alpha_1 \cdot L_5}{2 \cdot L_0 \cdot g} + \frac{m_2g \cdot \alpha_1 \cdot L_4}{2 \cdot L_0 \cdot g} = 4982.1 \text{ N} \quad P_{CRa} = P_C - \frac{m_1g \cdot \alpha_1 \cdot L_5}{2 \cdot L_0 \cdot g} - \frac{m_2g \cdot \alpha_1 \cdot L_4}{2 \cdot L_0 \cdot g} = -112.1 \text{ N}$$

$$P_{BRa} = P_B - \frac{m_1g \cdot \alpha_1 \cdot L_5}{2 \cdot L_0 \cdot g} - \frac{m_2g \cdot \alpha_1 \cdot L_4}{2 \cdot L_0 \cdot g} = 637.9 \text{ N} \quad P_{DRa} = P_D + \frac{m_1g \cdot \alpha_1 \cdot L_5}{2 \cdot L_0 \cdot g} + \frac{m_2g \cdot \alpha_1 \cdot L_4}{2 \cdot L_0 \cdot g} = 4262.1 \text{ N}$$

Load applied in lateral direction  $P_{ntLa}$

$$P_{AtLa} = \frac{m_1g \cdot \alpha_1 \cdot L_3}{2 \cdot L_0 \cdot g} = 255.1 \text{ N} \quad P_{CtLa} = -\frac{m_1g \cdot \alpha_1 \cdot L_3}{2 \cdot L_0 \cdot g} = -255.1 \text{ N}$$

$$P_{BtLa} = -\frac{m_1g \cdot \alpha_1 \cdot L_3}{2 \cdot L_0 \cdot g} = -255.1 \text{ N} \quad P_{DtLa} = \frac{m_1g \cdot \alpha_1 \cdot L_3}{2 \cdot L_0 \cdot g} = 255.1 \text{ N}$$

5. During deceleration to the right Load applied in radial direction  $P_{nRd}$  and Load applied in lateral direction  $P_{ntRd}$

$$P_{ARd} = P_A - \frac{m_1 g \cdot \alpha_3 \cdot L_5}{2 \cdot L_0 \cdot g} - \frac{m_2 g \cdot \alpha_3 \cdot L_4}{2 \cdot L_0 \cdot g} = 1429.4 \text{ N}$$

$$P_{BRd} = P_B + \frac{m_1 g \cdot \alpha_3 \cdot L_5}{2 \cdot L_0 \cdot g} + \frac{m_2 g \cdot \alpha_3 \cdot L_4}{2 \cdot L_0 \cdot g} = 4220.6 \text{ N}$$

$$P_{CRd} = P_C + \frac{m_1 g \cdot \alpha_3 \cdot L_5}{2 \cdot L_0 \cdot g} + \frac{m_2 g \cdot \alpha_3 \cdot L_4}{2 \cdot L_0 \cdot g} = 3470.6 \text{ N}$$

$$P_{DRd} = P_D - \frac{m_1 g \cdot \alpha_3 \cdot L_5}{2 \cdot L_0 \cdot g} - \frac{m_2 g \cdot \alpha_3 \cdot L_4}{2 \cdot L_0 \cdot g} = 679.4 \text{ N}$$

Load applied in lateral direction  $P_{ntRd}$

$$P_{AtRd} = - \frac{m_1 g \cdot \alpha_3 \cdot L_3}{2 \cdot L_0 \cdot g} = -85 \text{ N}$$

$$P_{CtRd} = \frac{m_1 g \cdot \alpha_3 \cdot L_3}{2 \cdot L_0 \cdot g} = 85 \text{ N}$$

$$P_{BtRd} = \frac{m_1 g \cdot \alpha_3 \cdot L_3}{2 \cdot L_0 \cdot g} = 85 \text{ N}$$

$$P_{DtRd} = - \frac{m_1 g \cdot \alpha_3 \cdot L_3}{2 \cdot L_0 \cdot g} = -85 \text{ N}$$

(3) Combined radial and thrus load  $P_{En}$

1. In uniform motion  $P_{En}$

$$P_{EA} = P_A = 2325 \text{ N}$$

$$P_{EC} = P_C = 2575 \text{ N}$$

$$P_{EB} = P_B = 3325 \text{ N}$$

$$P_{ED} = P_D = 1575 \text{ N}$$

2. During acceleration to the left  $P_{EnLa}$

$$P_{EALa} = |P_{ALa}| + |P_{AtLa}| = 617 \text{ N}$$

$$P_{EALd} = |P_{ALd}| + |P_{AtLd}| = 3305.6 \text{ N}$$

$$P_{EBLa} = |P_{BLa}| + |P_{BtLa}| = 6267.1 \text{ N}$$

$$P_{EBLd} = |P_{BLd}| + |P_{BtLd}| = 2514.4 \text{ N}$$

$$P_{ECLa} = |P_{CLa}| + |P_{CtLa}| = 5517.1 \text{ N}$$

$$P_{ECLd} = |P_{CLd}| + |P_{CtLd}| = 1764.1 \text{ N}$$

$$P_{EDLa} = |P_{DLa}| + |P_{DtLa}| = 1367.1 \text{ N}$$

$$P_{EDLd} = |P_{DLd}| + |P_{DtLd}| = 2555.6 \text{ N}$$

4. During acceleration to the right  $P_{EnRa}$

$$P_{EARa} = |P_{ARa}| + |P_{AtRa}| = 5237.2 \text{ N}$$

$$P_{EARd} = |P_{ARd}| + |P_{AtRd}| = 1514.4 \text{ N}$$

$$P_{EBRa} = |P_{BRa}| + |P_{BtRa}| = 893 \text{ N}$$

$$P_{EBRd} = |P_{BRd}| + |P_{BtRd}| = 4305.6 \text{ N}$$

$$P_{ECRa} = |P_{CRa}| + |P_{CtRa}| = 367.2 \text{ N}$$

$$P_{ECRd} = |P_{CRd}| + |P_{CtRd}| = 3555.6 \text{ N}$$

$$P_{EDRa} = |P_{DRa}| + |P_{DtRa}| = 4517.2 \text{ N}$$

$$P_{EDRd} = |P_{DRd}| + |P_{DtRd}| = 764.4 \text{ N}$$

3. During deceleration to the left  $P_{EnLd}$

5. During deceleration to the right  $P_{EnRd}$

#### (4) Static Safety Factor

As shown above, it is during acceleration of the B Linear Guide to the left when the maximum load is exerted on the Linear Guide. Therefore, the static safety factor ( $f_s$ ) becomes as follows :

$$f_s = \frac{C_0}{6267.1} = \frac{88329}{6267.1} = 14.9$$

#### (5) Mean Load $P_{mn}$

Unbalanced load at each Linear Guide block will cause during acceleration Uniform motion, and deceleration mean load ( $P_{mn}$ ) is a requirement to find out nominal life. First, calculate the move distances ( $S_1, S_2, S_3$ ) during acceleration, uniform motion, and deceleration of Linear.

$$S_1 = \frac{1}{2} t_1 V = \frac{1}{2} (0.05)(0.5)m = 0.0125m = 12.5mm \quad S_3 = \frac{1}{2} t_3 V = (0.15)(0.5)m = 0.0375m = 37.5mm$$

$$S_2 = t_2 V = (2.8)(0.5)m = 1.4m = 1400mm \quad \text{Nominal Life } L_s = S_1 + S_2 + S_3 = 1450mm$$

The mean load on each LM block is as follows :

$$P_{m_A} = \sqrt[3]{\frac{1}{2 \cdot L_s} (P_{EA}^3 \cdot a \cdot S_1 + P_{EA}^3 \cdot S_2 + P_{EA}^3 \cdot d \cdot S_3 + P_{EA}^3 \cdot R_a \cdot S_1 + P_{EA}^3 \cdot S_2 + P_{EA}^3 \cdot R_d \cdot S_3)} = 2367.3N$$

$$P_{m_B} = \sqrt[3]{\frac{1}{2 \cdot L_s} (P_{EB}^3 \cdot a \cdot S_1 + P_{EB}^3 \cdot S_2 + P_{EB}^3 \cdot d \cdot S_3 + P_{EB}^3 \cdot R_a \cdot S_1 + P_{EB}^3 \cdot S_2 + P_{EB}^3 \cdot R_d \cdot S_3)} = 3355.9N$$

$$P_{m_C} = \sqrt[3]{\frac{1}{2 \cdot L_s} (P_{EC}^3 \cdot a \cdot S_1 + P_{EC}^3 \cdot S_2 + P_{EC}^3 \cdot d \cdot S_3 + P_{EC}^3 \cdot R_a \cdot S_1 + P_{EC}^3 \cdot S_2 + P_{EC}^3 \cdot R_d \cdot S_3)} = 2614N$$

$$P_{m_D} = \sqrt[3]{\frac{1}{2 \cdot L_s} (P_{ED}^3 \cdot a \cdot S_1 + P_{ED}^3 \cdot S_2 + P_{ED}^3 \cdot d \cdot S_3 + P_{ED}^3 \cdot R_a \cdot S_1 + P_{ED}^3 \cdot S_2 + P_{ED}^3 \cdot R_d \cdot S_3)} = 1638.9N$$

#### (6) Nominal life $L_n$ (Assume $F_w = 1.5$ )

$$(L_A = \frac{C}{f_w \cdot P_{mA}})^3 \cdot 50 = 115939 \text{ km} \quad (L_C = \frac{C}{f_w \cdot P_{mC}})^3 \cdot 50 = 86113.86 \text{ km}$$

$$(L_B = \frac{C}{f_w \cdot P_{mB}})^3 \cdot 50 = 40697 \text{ km} \quad (L_D = \frac{C}{f_w \cdot P_{mD}})^3 \cdot 50 = 349407.7 \text{ km}$$

※ From these calculations, 40697 km (the running distance of Linear Guide No.B) is obtained as the service life of the Linear Guide used in a machine or system under the operating conditions specified above.※

In the example above, we assume that we have two loads ( $w_1$  and  $w_2$ ). If there is only one load  $w_1$ ,  $w_2$  should be re-calculated by being set as zero. The appropriate formula determined by condition of loading.



## Example(2)

### (1) Operation Conditions-Vertical Installations

Fig. Table (L type) has combined blocks weigh  $W_1$  and  $W_2$ . Furthermore, the mass  $W_0$  is applied during uniform ascent by Distance 1000mm. After the mass is dropped, empty table is removed during uniform descent. The table has total four Linear Guide blocks.

Model number: TRH30FE

(dynamic-load rating :  $C = 47 \text{ KN}$ )

(static-load rating :  $C_0 = 88.329 \text{ KN}$ )

Gravitational Acceleration :  $g = 9.8 \text{ (m/s}^2\text{)}$

Mass :  $m_0g = 2000\text{N}$

Weight of Table1 :  $m_1g = 4000\text{N}$

Weight of Table1 :  $m_2g = 2000\text{N}$

$L_0=300\text{mm}$

$L_1=80 \text{ mm}$

$L_2=50 \text{ mm}$

$L_3=280\text{mm}$

$L_4=150\text{mm}$

$L_5=250\text{mm}$

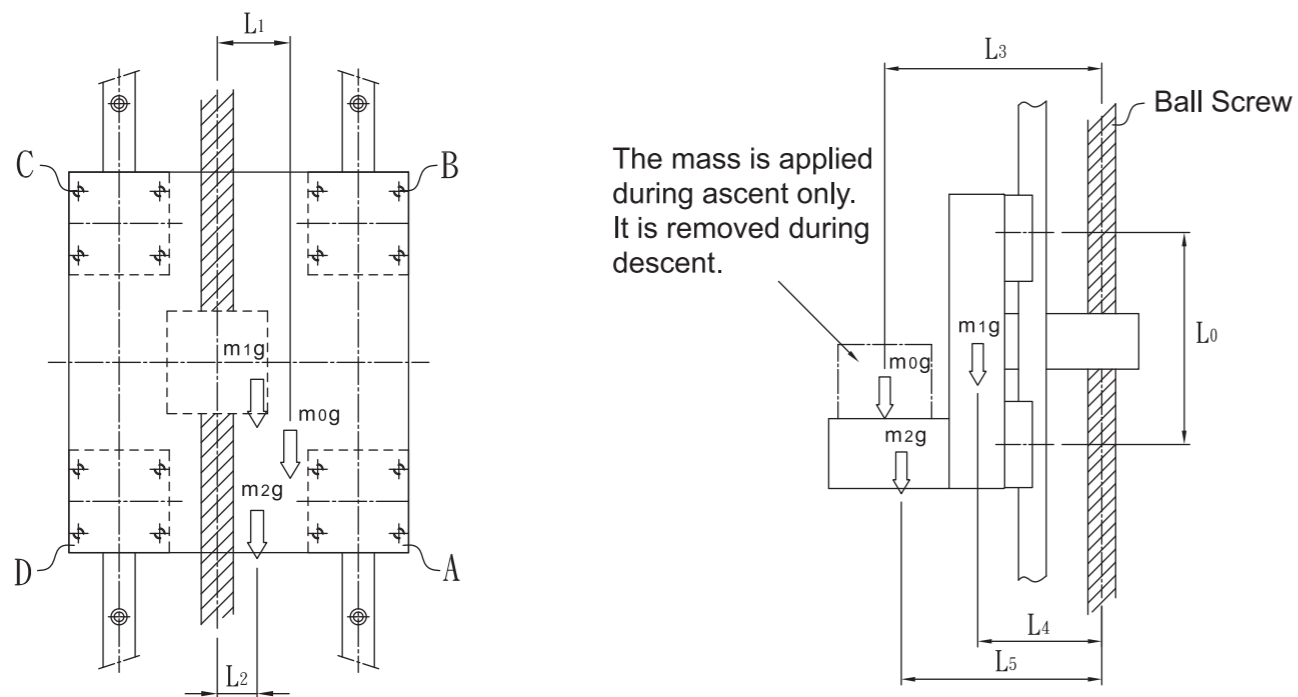

Fig1.7.4 Operating Condition

### (2) Load Exerted on the Linear Guide by the Linear Guide Block

Base on the third condition of Linear Guide is regarding vertical motion to figure out load exerted. [please see page 15. No.3]. Combined influence by  $m_0g$ 、 $m_1g$ 、 $m_2g$ .

#### 1. Load exerted on the Linear Guide in radial direction $P_{nu}$ by the Linear Guide block.

$$P_{AU} = \frac{m_1g \cdot L_4}{2 \cdot L_0} + \frac{m_2g \cdot L_5}{2 \cdot L} + \frac{m_0g \cdot L_3}{2 \cdot L_0} = 2767\text{N} \quad P_{CU} = \frac{m_1g \cdot L_4}{2 \cdot L_0} - \frac{m_2g \cdot L_5}{2 \cdot L} - \frac{m_0g \cdot L_3}{2 \cdot L_0} = -2767\text{N}$$

$$P_{BU} = -\frac{m_1g \cdot L_4}{2 \cdot L_0} - \frac{m_2g \cdot L_5}{2 \cdot L} - \frac{m_0g \cdot L_3}{2 \cdot L_0} = -2767\text{N} \quad P_{DU} = \frac{m_1g \cdot L_4}{2 \cdot L_0} + \frac{m_2g \cdot L_5}{2 \cdot L} + \frac{m_0g \cdot L_3}{2 \cdot L_0} = 2767\text{N}$$

#### Load exerted on the Linear Guide in lateral direction $P_{nTu}$ by the Linear Guide block.

$$P_{ATU} = \frac{m_1g \cdot L_2}{2 \cdot L_0} + \frac{m_2g \cdot L_2}{2 \cdot L} + \frac{m_0g \cdot L_1}{2 \cdot L_0} = 767\text{N} \quad P_{CTU} = -\frac{m_1g \cdot L_2}{2 \cdot L_0} - \frac{m_2g \cdot L_2}{2 \cdot L} - \frac{m_0g \cdot L_1}{2 \cdot L_0} = -767\text{N}$$

$$P_{BTU} = -\frac{m_1g \cdot L_2}{2 \cdot L_0} - \frac{m_2g \cdot L_2}{2 \cdot L} - \frac{m_0g \cdot L_1}{2 \cdot L_0} = -767\text{N} \quad P_{DTU} = \frac{m_1g \cdot L_2}{2 \cdot L_0} + \frac{m_2g \cdot L_2}{2 \cdot L} + \frac{m_0g \cdot L_1}{2 \cdot L_0} = 767\text{N}$$

#### 2. Load exerted on the Linear Guide in radial direction $P_{nD}$ by the Linear Guide block.

$$P_{AD} = \frac{m_1g \cdot L_4}{2 \cdot L_0} + \frac{m_2g \cdot L_5}{2 \cdot L} = 1833.3\text{N} \quad P_{CD} = -\frac{m_1g \cdot L_4}{2 \cdot L_0} - \frac{m_2g \cdot L_5}{2 \cdot L} = -1833.3\text{N}$$

$$P_{BD} = -\frac{m_1g \cdot L_4}{2 \cdot L_0} - \frac{m_2g \cdot L_5}{2 \cdot L} = -1833.3\text{N} \quad P_{DD} = \frac{m_1g \cdot L_4}{2 \cdot L_0} + \frac{m_2g \cdot L_5}{2 \cdot L} = 1833.3\text{N}$$

#### Load exerted on the Linear Guide in lateral direction $P_{nTD}$ by the Linear Guide block

$$P_{ATD} = \frac{m_1g \cdot L_2}{2 \cdot L_0} + \frac{m_2g \cdot L_2}{2 \cdot L} + \frac{m_0g \cdot L_1}{2 \cdot L_0} = 500\text{N} \quad P_{CTD} = -\frac{m_1g \cdot L_2}{2 \cdot L_0} - \frac{m_2g \cdot L_2}{2 \cdot L} - \frac{m_0g \cdot L_1}{2 \cdot L_0} = -500\text{N}$$

$$P_{BTD} = -\frac{m_1g \cdot L_2}{2 \cdot L_0} - \frac{m_2g \cdot L_2}{2 \cdot L} - \frac{m_0g \cdot L_1}{2 \cdot L_0} = -500\text{N} \quad P_{DTD} = \frac{m_1g \cdot L_2}{2 \cdot L_0} + \frac{m_2g \cdot L_2}{2 \cdot L} + \frac{m_0g \cdot L_1}{2 \cdot L_0} = 500\text{N}$$

### (3) Combined radial and thrust load Pen

1. During ascent

$$P_{EAU} = |P_{AD}| + |P_{ATU}| = 3534 \text{ N}$$

$$P_{EBU} = |P_{BD}| + |P_{BTU}| = 3534 \text{ N}$$

$$P_{ECU} = |P_{CD}| + |P_{CTU}| = 3534 \text{ N}$$

$$P_{EDU} = |P_{DD}| + |P_{DTU}| = 3534 \text{ N}$$

2. During descent

$$P_{EAD} = |P_{AD}| + |P_{ATD}| = 2333.3 \text{ N}$$

$$P_{EBD} = |P_{BD}| + |P_{BTD}| = 2333.3 \text{ N}$$

$$P_{ECD} = |P_{CD}| + |P_{CTD}| = 2333.3 \text{ N}$$

$$P_{EDD} = |P_{DD}| + |P_{DTD}| = 2333.3 \text{ N}$$

### (4) Static Safety Factor

The static safety factor ( $f_s$ ) of a machine or system under the operating conditions shown above becomes the following :

$$f_s = \frac{C_0}{3534 \text{ N}} = \frac{88329}{3534} = 24.99$$

### (5) Mean Load Pmn

$$P_{m_A} = \sqrt[3]{\frac{1}{2l_s} (P_{EAU}^3 \cdot l_s + P_{EAD}^3 \cdot l_s)} = 3051.7 \text{ N} \quad P_{m_C} = \sqrt[3]{\frac{1}{2l_s} (P_{ECU}^3 \cdot l_s + P_{ECD}^3 \cdot l_s)} = 3051.7 \text{ N}$$

$$P_{m_B} = \sqrt[3]{\frac{1}{2l_s} (P_{EBU}^3 \cdot l_s + P_{EBD}^3 \cdot l_s)} = 3051.7 \text{ N} \quad P_{m_D} = \sqrt[3]{\frac{1}{2l_s} (P_{EDU}^3 \cdot l_s + P_{EDD}^3 \cdot l_s)} = 3051.7 \text{ N}$$

### (6) Nominal life $L_n$ (Assume $f_w=1.2$ )

$$L_A = \left( \frac{C}{f_w \cdot P_{mA}} \right)^3 \cdot 50 \text{ km} = 105704.7 \text{ km} \quad L_C = \left( \frac{C}{f_w \cdot P_{mC}} \right)^3 \cdot 50 \text{ km} = 105704.7 \text{ km}$$

$$L_B = \left( \frac{C}{f_w \cdot P_{mB}} \right)^3 \cdot 50 \text{ km} = 105704.7 \text{ km} \quad L_D = \left( \frac{C}{f_w \cdot P_{mD}} \right)^3 \cdot 50 \text{ km} = 105704.7 \text{ km}$$

## 1-8 Installation of Linear Guide

### 1-8-1 Datum representation

Jointed rail should be installed by following the arrow sign and ordinal number which is marked on the surface of each rail (see Fig1.8.1) :

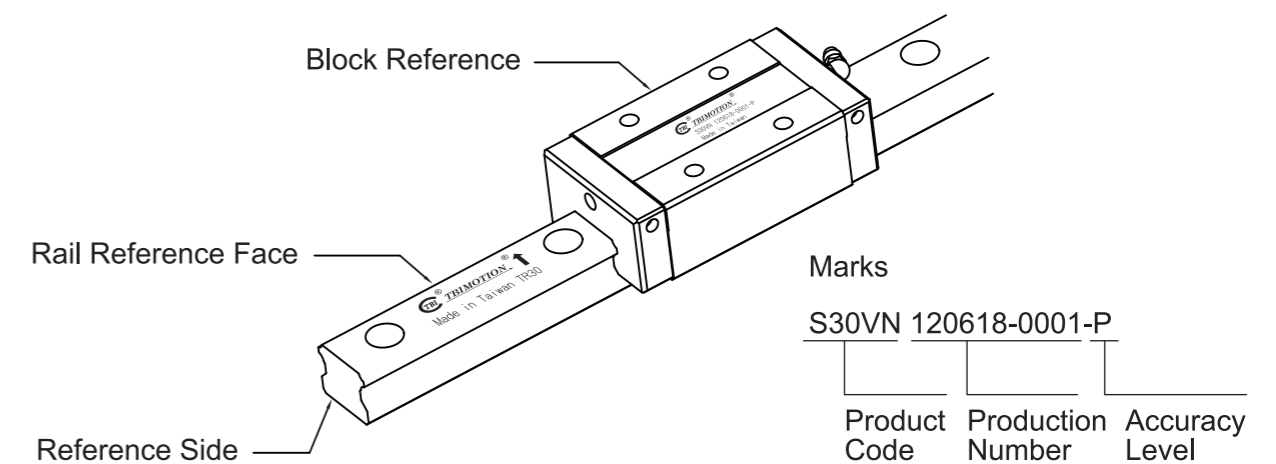

Fig1.8.1 Datum representation

## 1-8-2 Recognizing of Master Rail

Linear rails to be applied on the same plane are all marked with the same serial number, and "M" is marked at the end of serial number for indicating the master rail, shown as the figure below. The reference side of carriage is the surface where is ground to a specified accuracy. For normal grade (N), it has no mark "M" on rail which means any one of rails with same serial number could be the master rail.

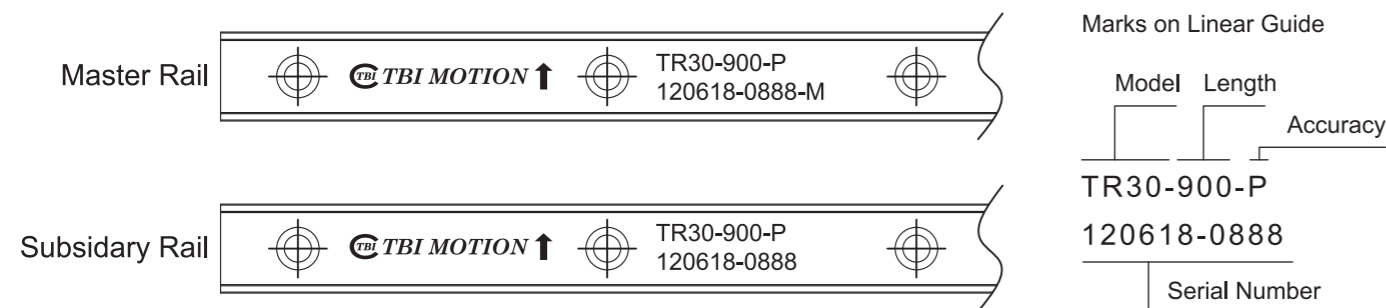

Fig1.8.2 Recognizing of Master Rail

## Combined Use of Rail and Carriage

For combined use, the rail and carriage must have the same serial number. When reinstalling the carriage back to the rail, make sure they have the same serial number and the reference side of carriage should be in accordance with that of rail.

## 1-8-3 For Butt-joint Rail

Accuracy may deviate at joints when carriages pass the joint simultaneously. Therefore, the joints should be interlaced for avoiding such accuracy problem.

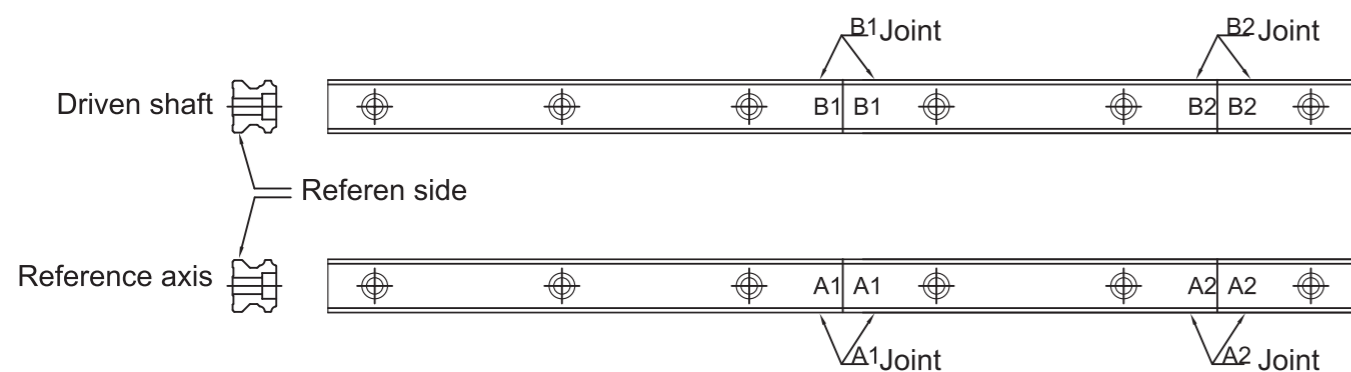

Fig1.8.3 Butt-joint

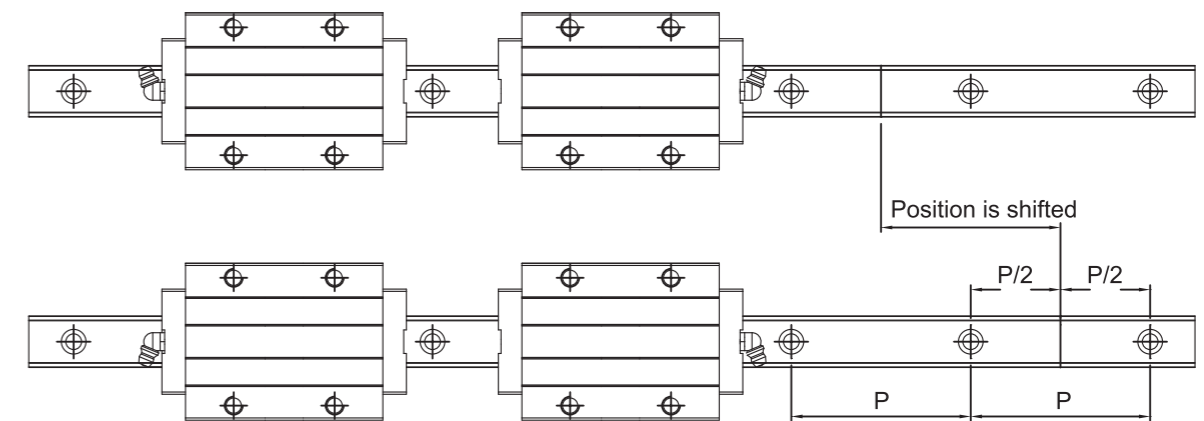
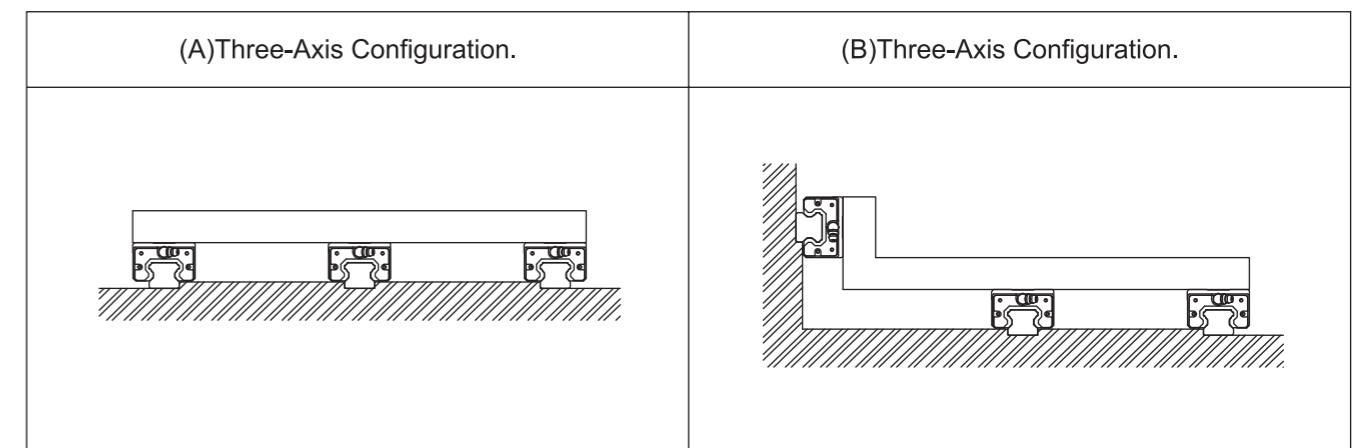
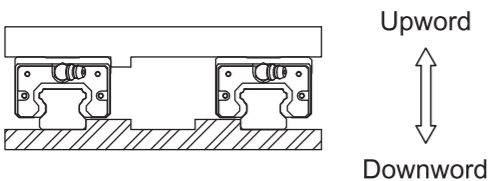
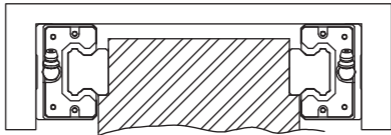
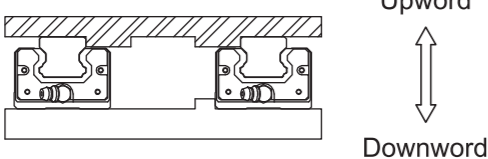
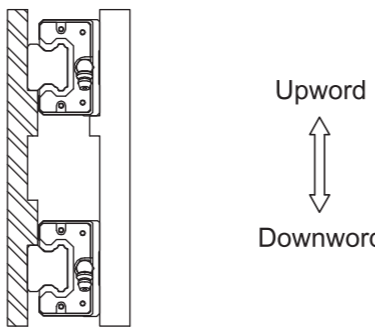
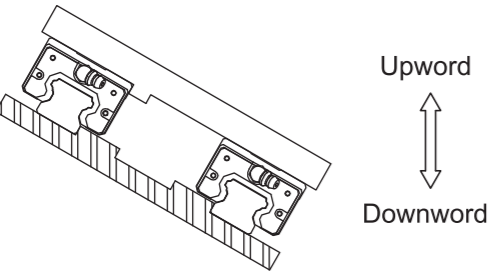
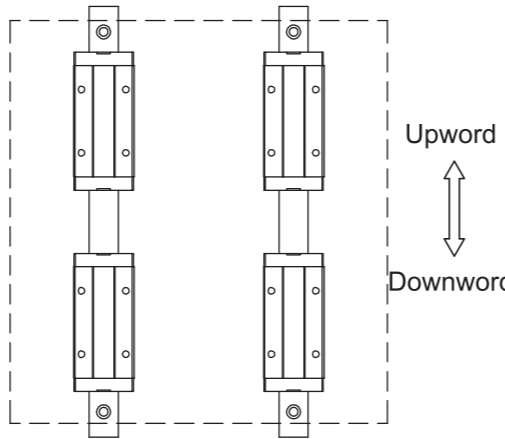

Fig1.8.4

## 1-8-4 Mounting methods

Linear rail is designed to absorb the load of four dimensions; therefore it can be mounted according to the load and structure of the equipment.



Horizontal Configuration.	Two-Axis External Configuration.
	
Upside down Configuration.	Vertical Configuration.
	
Tilted Configuration.	Install on the wall.
	

## 1-8-5 Common Fastening Method of Linear Guide

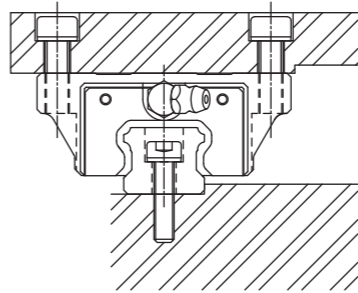
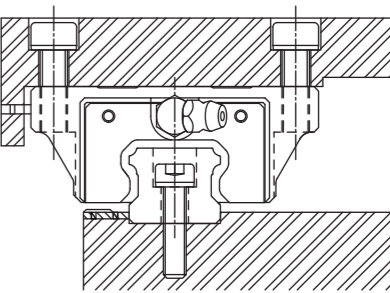
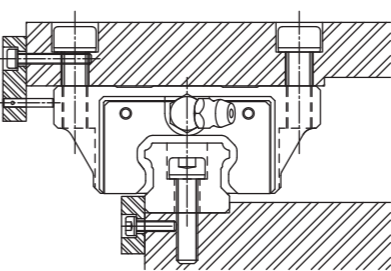
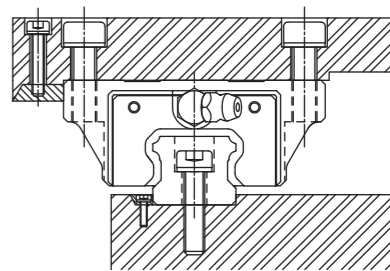
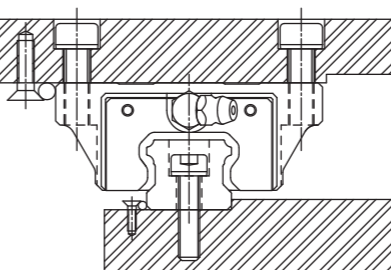
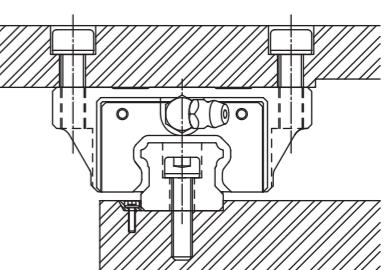
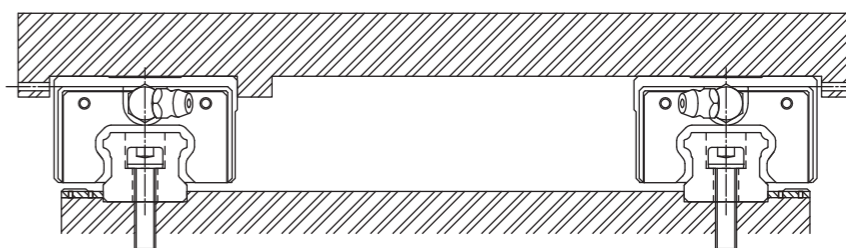
Fastened by pressing both Linear Guide blocks and rail against their respective reference surfaces.	Fastened by using push screws.
	
Fastened by using a hold-down plate.	Fastened by using a tapered gib.1
	
Fastened by using screws.	Fastened by using a tapered gib.2
	
A Seeting Where the Host Machine is Subjected to Impact and Vibration.	
	



## 1-8-6 Mounting the Linear Guide

### Mounting Procedures

※※※※ Sample Installation of the Linear Guide on a Vibration-and-Impact Susceptible Machine that Requires Rigidity and High Precision. ※※※※

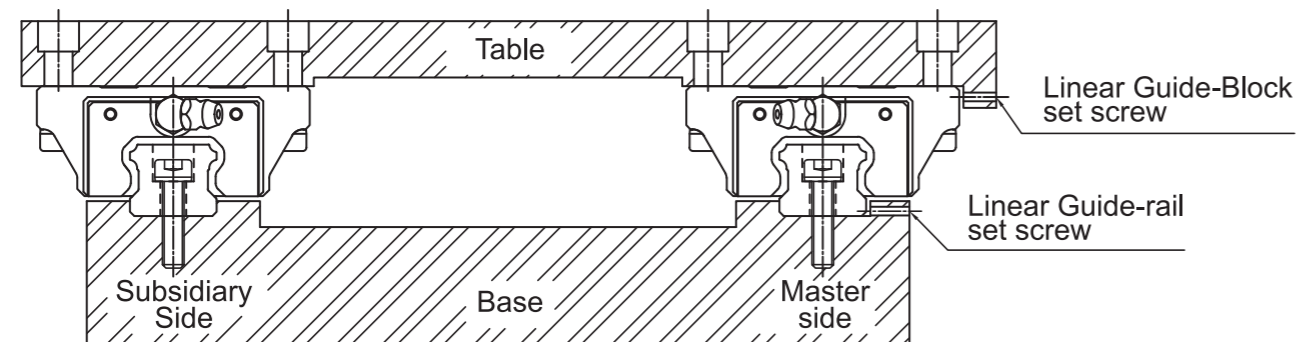

Fig1.8.5 Mounting the Linear Guide on a Machine Susceptible to Vibration and Impact.

### Mounting the Linear Guide Rail

(A) Prior to assembly, always remove all burrs, dents, dust, and the like from the mounting surface of the machine on which the Linear Guide is to be installed. (Fig1.8.6)

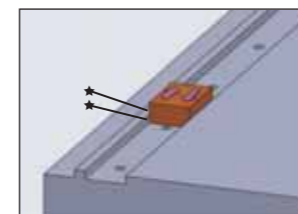

Fig 1.8.6 Checking the Mounting Surface.

CAUTION : The Linear Guide is delivered with an anticorrosive oil applied. Prior to assembly, be sure to remove the oil from the reference surface using a wash oil. If the anticorrosive oil is removed, the surface is likely to rust. The application of a low-viscosity spindle oil or the like is therefore recommended.

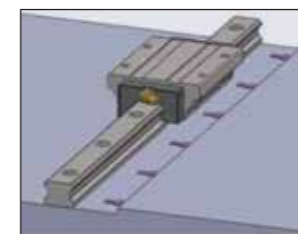

Fig1.8.7 Holding an Linear Guide rail against the Reference Surface

(B) Gently place an Linear Guide rail on the base, and temporarily tighten the bolts so that the rail lightly contacts the mounting surface. Hold the line-marked side of the Linear Guide rail against matching the base-side reference surface (Fig1.8.7)

CAUTION : Use clean bolts to fasten the Linear Guide. When inserting bolts into the Linear Guide rail mounting holes, make sure the threads of the bolt and nut are properly aligned. (Fig1.8.8)

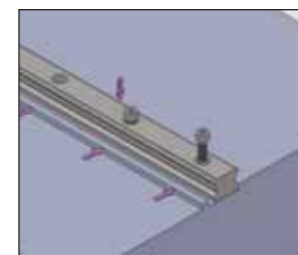

Fig1.8.8 Checking Bolt Play

Table1.8.1 Tightening Torque for Hexagonal-Socket Head Bolts

Unit : N-cm

Model No.	Tightening Torque		
	Iron	Casting	Aluminum
M2	58.2	39.2	29.4
M2.3	78.4	53.9	39.2
M2.6	118	78.4	58.8
M3	196	127	98.0
M4	412	274	206
M5	882	588	441
M6	1370	921	686
M8	3040	2010	1470
M10	6760	4510	3330
M12	11800	7840	5880
M14	15700	10500	7840
M16	19600	13100	9800
M20	38200	25500	19100
M22	51900	34800	26000
M24	65700	44100	32800
M30	130000	87200	65200

(C) Tighten the Linear Guide rail set screws in sequence, until they lightly contact the rail-mounting side surface (Fig1.8.9).

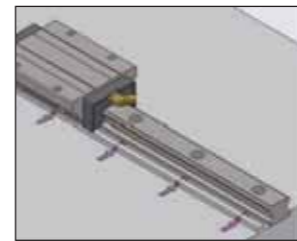

Fig1.8.9 Tightening Set Screws

(D) Using a torque wrench, tightening the mounting bolts to the specified torque (Fig1.8.10).

CAUTION : The sequence for tightening the Linear Guide – rail mounting bolts should start from the center to the end. Following this sequence enables stable accuracy to be achieved.

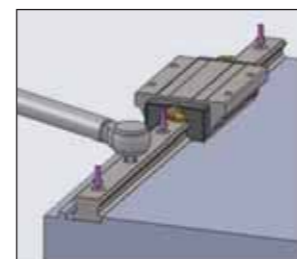

Fig1.8.10 Full Tightening of Mounting Bolts

(E) Following the same procedures for the remaining Linear Guide rails, complete Linear Guide rail installation.

(F) Drive caps into the bolt holes on the Linear Guide rails so that they are flush with the rail top surface.

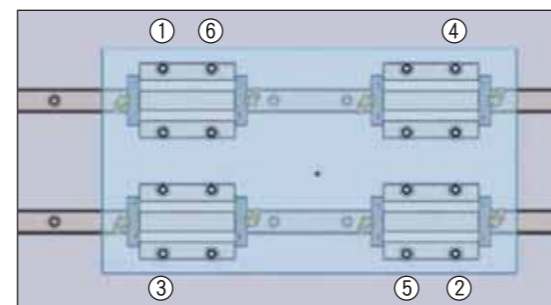

Fig1.8.11

## Mounting the Linear Guide Block

(A) Gently place a table on the Linear Guide blocks and temporarily tighten the mounting bolts.

(B) Using set screws, hold the master-rail Linear Guide block against the table reference-side surface, and position the table.

(C) Fully tighten the mounting bolts on both the master and subsidiary sides. This completes Linear Guide block installation.

CAUTION : To ensure uniform fastening of the table, tighten the mounting bolts diagonally, as shown in (Fig1.8.11) in accordance with the numbers.

The method specified above minimizes the time required to ensure the straightness of the Linear Guide-rail. Moreover, there is no need to use the fastening knock pins, thereby greatly reducing the required assembly man-hours.

※※※※※ Sample Installation of the Linear Guide without Set Screws on the Master Linear Guide Rail ※※※※※

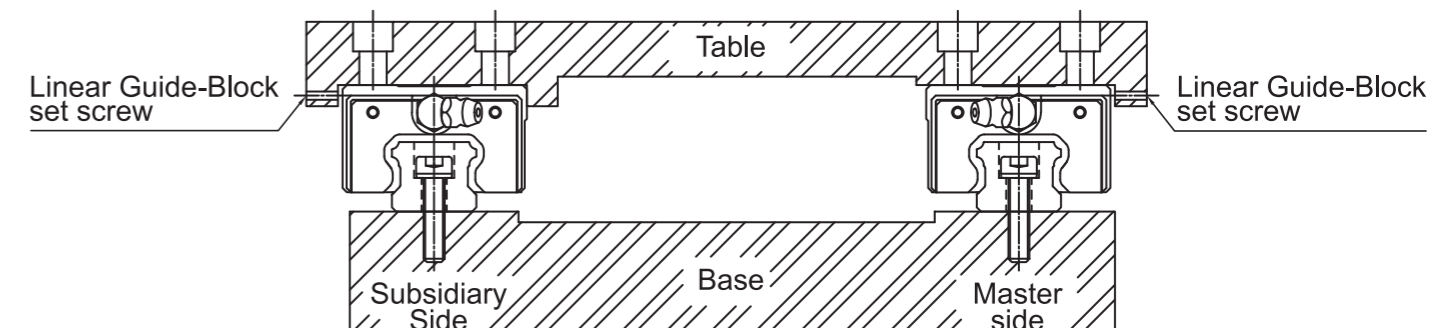

Fig1.8.12 Mounting the Linear Guide without Set Screws on the Master Linear Guide Rail

## Mounting the Master Linear Guide Rail

After temporarily tightening the mounting bolts, use a small device or the like to firmly press the rail to the side, against the reference section. Fully tighten the mounting bolts. Repeat this for each mounting bolt in sequence. (Fig1.8.13)

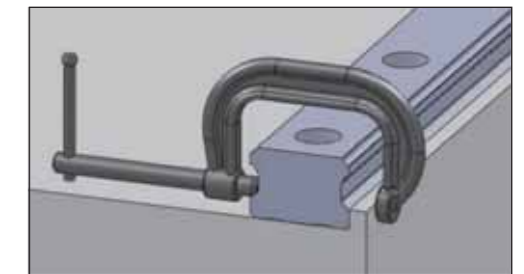

Fig1.8.13 Mounting the master Linear Guide rail

## Mounting the Subsidiary Linear Guide Rail

To ensure parallelism of the subsidiary Linear Guide rail with the master Linear Guide rail properly mounted, the following methods are recommended.

### Use a Straight Edge

Position a straight edge between the two rails so that it is parallel with the master-Linear Guide-rail-side reference surface, and confirm parallelism using a dial gauge. Using the straight edge as a reference, confirm subsidiary-rail straightness from one end to the other, tightening the mounting bolts in sequence as you go (Fig1.8.14).

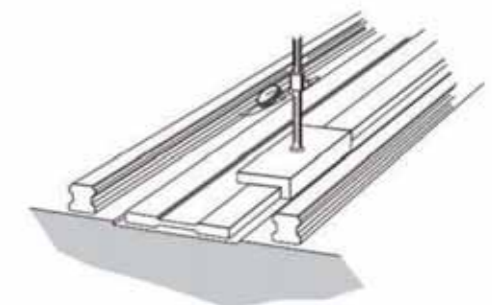

Fig1.8.14 Use a straight edge

## Move the Table

Fasten two Linear Guide blocks on the master side to the table (or a temporary measurement table). Temporarily fasten the subsidiary Linear Guide rail and block to the base and table. From the dial-gauge stand, have a dial gauge contact the subsidiary-rail Linear Guide block side. Move the table from the rail end and check the parallelism between the block and the subsidiary Linear Guide rail, fastening the bolts in sequence as you go. (Fig1.8.15)

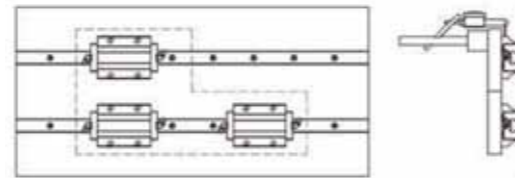

Fig1.8.15 Move the table

## Compare to the Master Linear Guide Rail

Make sure the master Linear Guide rail is properly installed. Temporarily fasten the subsidiary Linear Guide rail in place. Place a table on the Linear Guide blocks mounted on the master rail and on the temporarily fastened subsidiary Linear Guide rail. Fully tighten the mounting bolts on the two Linear Guide blocks on the subsidiary rail. With the remaining Linear Guide block on the subsidiary rail temporarily fastened, correct the position of the subsidiary Linear Guide rail, fully tightening its mounting bolts in sequence as you go. (Fig1.8.16)

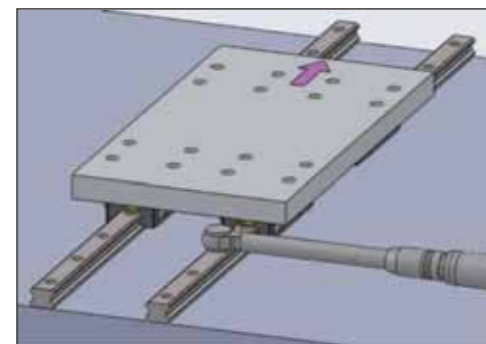

Fig1.8.16 Compare to the master Linear Guide rail

## Method Using a Jig

Using a jig as shown in (Fig1.8.17) confirm parallelism between the master-rail-side reference surface and that of the subsidiary rail at each mounting hole, and fully tighten the mounting bolt there.

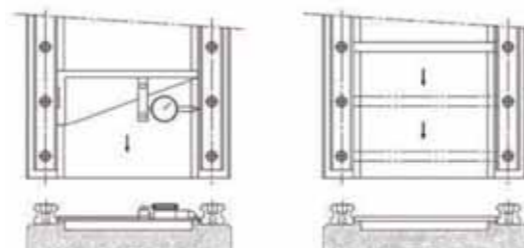

Fig1.8.17

※※※※ Sample Installation of the Linear Guide without a Reference Section for the Master Linear Guide Rail ※※※※

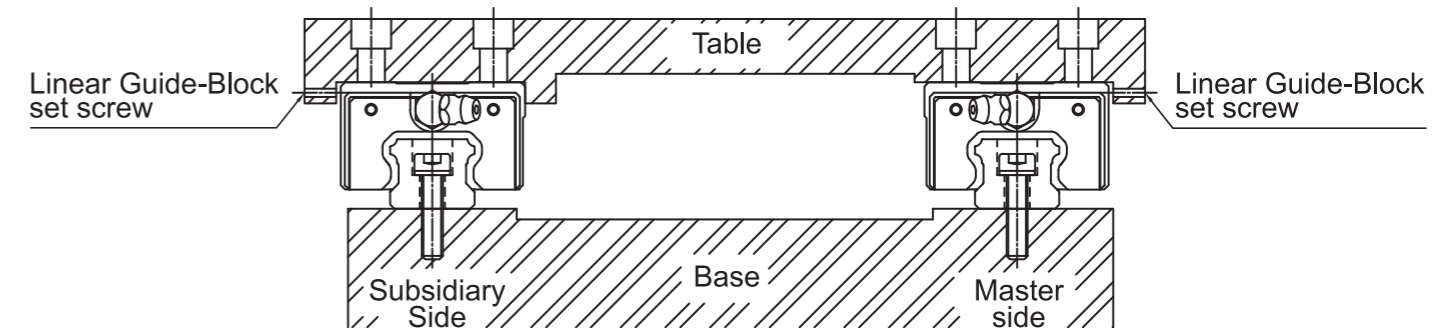

Fig1.8.18 Installation of the Linear Guide without a Reference Section for the Master Linear Guide Rail

## Mounting the Master Linear Guide Rail Use a temporary reference surface

Linear Guide-rail straightness from end to end can be achieved with the aid of a surface temporarily set as the reference surface near the Linear Guide-rail mounting surface on the base. For this method, however, two Linear Guide blocks must be fastened together, positioned on top of each other, while attached to a measurement plate, as shown in Fig1.8.19.

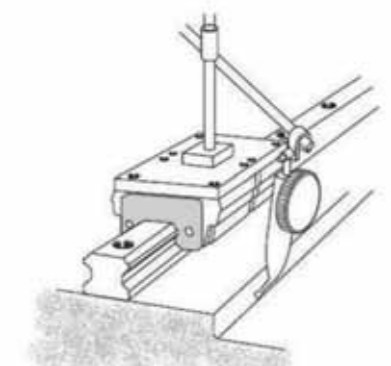

Fig1.8.19 Use a temporary reference surface

## Use a straight edge

After temporarily tightening the mounting bolts, use a dial gauge to check the straightness of the Linear Guide-rail-side reference surface from end to end, fully tightening the mounting bolts in sequence as you go, as shown in (Fig1.8.20).

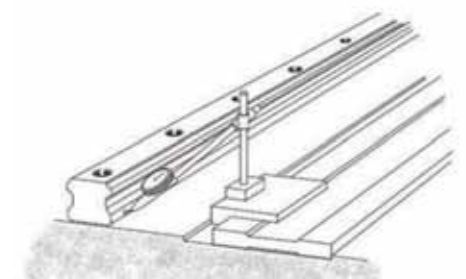

Fig1.8.20 Use a straight edge

To mount the subsidiary Linear Guide rail, follow the procedures specified in the second paragraph on the previous page.



## Shoulder Heights and Chamfers

Improper shoulder heights and chamfers of mounting surfaces will cause deviations in accuracy and rail or block interference with the chamfered part. When recommended shoulder heights and chamfers are used, problems with installation accuracy should be eliminated.

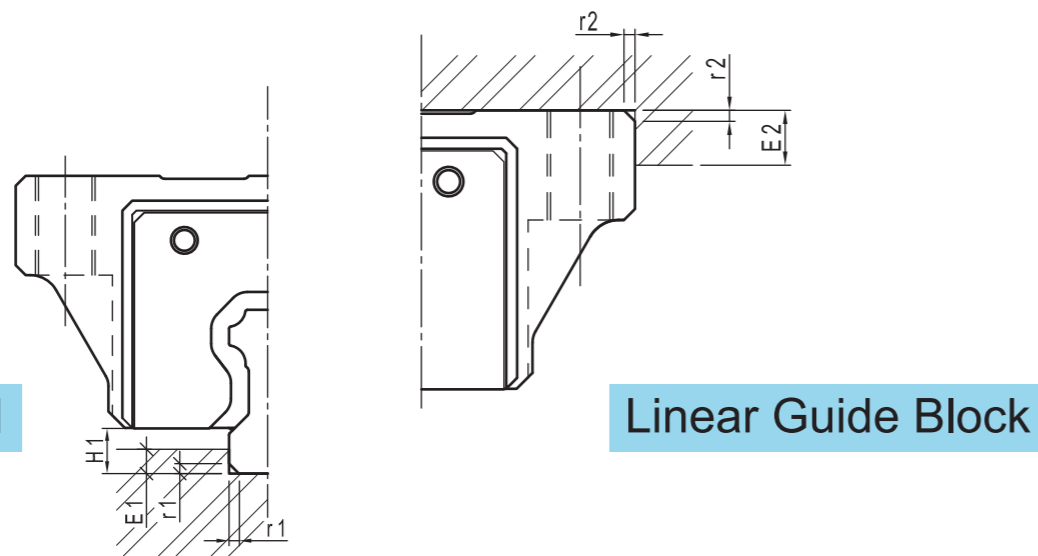

Fig1.8.21

Table1.8.2 Shoulder Heights and Chamfers

Model No.	Max.chamfers of the rail R1	Max.chamfers of the block R2	Max.chamfers of the rail E1	Max.chamfers of the rail E2	Max.chamfers of the block H1
TR15	0.5	0.5	3	4	3.2
TR20	0.5	0.5	3.5	5	4.6
TR25	1.0	0.9	5	5	5.8
TR30	1.0	1	5	5	7
TR35	1.0	1	6	6	7.5
TR45	1.0	1	8	8	8.9
TR55	1.5	1.5	10	10	13
TR65	1.5	1.5	8	10	14.3

## 1-9 Friction Coefficient

The construction of Linear Guide are block, rail and motion system which has rolling elements, such as balls and rollers, placed between two raceways. The rolling motion that rolling elements give rise to reduce the frictional resistance to 1/20 th to 1/40 th of that in a slide guide. Static friction, in particular, is much lower in a linear motion system than in other system, and there is little difference between static and dynamic friction, so that stick-slip does not occur. Therefore, Linear Guide could apply in various precision motion system. Frictional resistance in a linear motion system varies with the type of linear motion system, the magnitude of the preload, the viscosity resistance of the lubricant used the load exerted on the system, and other factors. Table shows Friction of Linear Guide.

### Formula of Friction :

$$F = \mu \times w + f$$

F : Friction

W : Load

$\mu$  : Friction Coefficient

f : TR Frictional Resistance

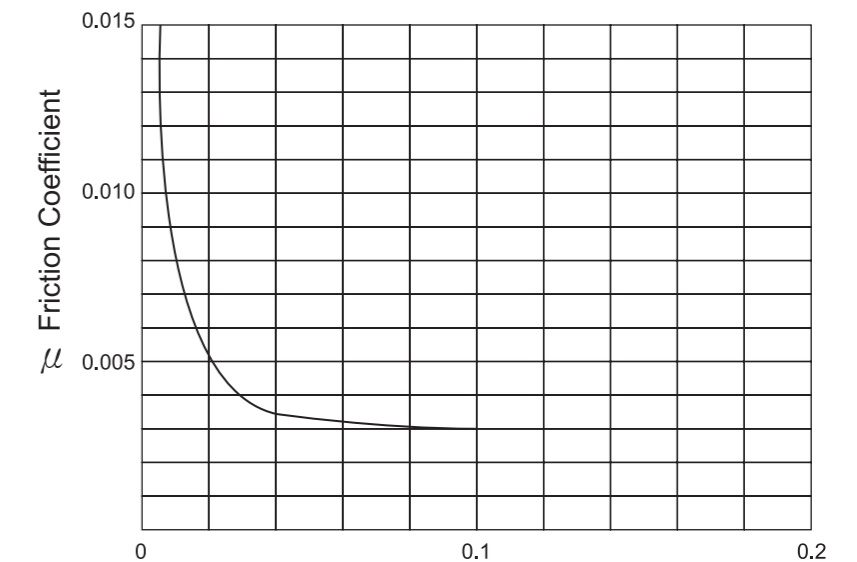

Fig1.9.1

Table.1.9.1 Friction Coefficient  $\mu$  of Various Linear Motion Systems  $\mu$

Type of Linear Motion System	Friction Coefficient
Linear Guide	0.002 ~ 0.003
Ball Spline	0.002 ~ 0.003
Linear Guide Roller	0.0050 ~ 0.010
Cross Roller Guide	0.0010 ~ 0.0025
Linear Ball Slide	0.0006 ~ 0.0012

Imposed Load Ratio (P/C)

P : Imposed Load

C : Basic Dynamic Load Rating



## 1-10 Designing Rigidity

### 1-10-1 Determining Radial Clearance and the Magnitude of a Preload

#### Radial Clearance

The radial clearance of the Linear Guide is the displacement of Linear Guide block caused by the vertical plane when the block is lightly pushed forward or backward at the longitudinal center of the Linear Guide rail secured in place.

The radial clearance is divided into Slight Clearance. (ZF), No Preload (ZO), Clearance Z1 (under a light preload), Z2 (under a medium preload) and Z3 (under a heavy preload). The most appropriate clearance can be selected in accordance with the intended applications. The radial clearances and preload values are standardized for each type of Linear Guide.

The radial clearance of the Linear Guide significantly affects its running precision, load-withstanding performance, and rigidity. It is therefore particularly important to select the correct clearance for your purpose. In generally, a negative clearance has a favorable effect on service life and precision, if the Linear Guide is subjected to significant vibration and impact due to reciprocal motion.

#### Preload

The preload is an internal load exerted on rolling elements in the Linear Guide block, for the purposes of increasing the block rigidity and reducing clearances. Clearance symbols for the Linear Guide, ZF, Z0, Z1, Z2 and Z3 represent negative clearances resulting from a preload and are expressed in negative values. All Linear Guide models (excluding the separate type) are shipped with their clearances adjusted to user specifications. Therefore, it is not necessary for users to adjust the preload themselves. We will select the clearances best suited to your operating conditions. Please contact us.

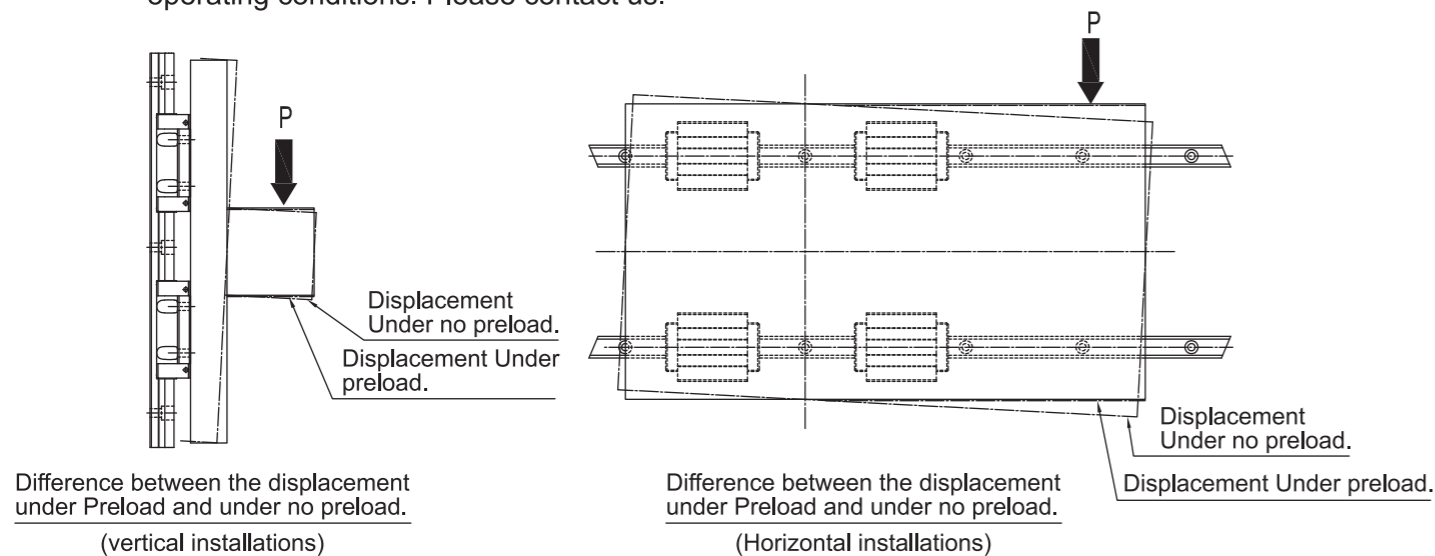

Fig1.10.1 Relationship Between Preload and Displacement

Table1.10.1

	Preload		
	ZF~Z0 Slight Clearance, Zero Preload.	Z1 Zero Clearance, Light Preload.	Z2 Zero Clearance, Medium preload.
Operating conditions	The loading direction is fixed; impact and vibration are slight; two axes are installed in parallel.  Very high precision is not required and the sliding resistance must be as low as possible.	The location is under an overhang and a moment load. The Linear Guide is used in a one-axis configuration.  The location requires a light load and high precision.	The location requires light rigidity and is subjected to vibration and impact.  The application is a heavy-cutting machine tool or the like.
Sample applications	<ul style="list-style-type: none"> <li>◆ Beam-welding machine.</li> <li>◆ Book-binding machine.</li> <li>◆ automatic packing machine.</li> <li>◆ general-industrial-machine.</li> <li>◆ X-and Y-axes.</li> <li>◆ automatic sash-bar finishing machine.</li> <li>◆ welding machine.</li> <li>◆ arc cutter.</li> <li>◆ tool changer.</li> <li>◆ various kinds of maternal feeder.</li> </ul>	<ul style="list-style-type: none"> <li>◆ Grinding-machine table feed shaft.</li> <li>◆ automatic painting machine.</li> <li>◆ industrial robot.</li> <li>◆ various kinds of high-speed material feeder.</li> <li>◆ NC drilling machine.</li> <li>◆ general-industrial-machine.</li> <li>◆ Z-axis.</li> <li>◆ printed-circuit-board drilling machine.</li> <li>◆ electric discharge machine.</li> <li>◆ measuring instrument.</li> <li>◆ precision XY table.</li> </ul>	<ul style="list-style-type: none"> <li>◆ Machining center.</li> <li>◆ NC lathe.</li> <li>◆ grinding-machine grinding-wheel feed shaft.</li> <li>◆ milling machine.</li> <li>◆ vertical-and horizontal-boring machines.</li> <li>◆ tool rest guide.</li> <li>◆ machine-tool Z-axis.</li> </ul>

#### Applied Load and Service Life Considering Preload

When the Linear Guide is used under a preload (medium), the Linear Guide block receives an internal load. Therefore, the service life should be calculated in consideration of the preload. For preload considerations, please contact us, specifying the model numbers you have selected.

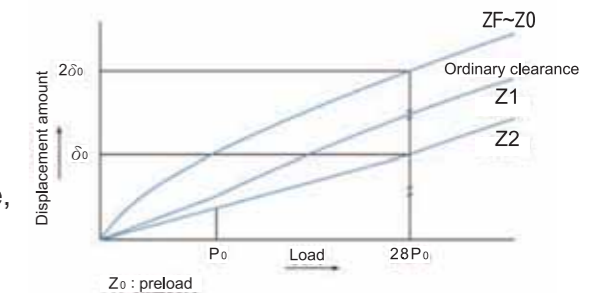

Fig1.10.2 Rigidity Data

$$\delta = \frac{P}{K} \mu m$$

$\delta$  : Displacement  
 $P$  : Load  
 $K$  : Rigidity Value

#### 1-10-2 Rigidity

When the Linear Guide receives a load, the balls, Linear Guide blocks, and rails undergo elastic deformation within a permissible range. The ratio of displacement at this deformation to the load received is known as the rigidity value. The rigidity of the Linear Guide increases as the preload increases. Fig shows the differences among the ordinary clearance Z1 and clearance Z2, Z3. As shown, in the case of the four-way equal-load type, the effect of preloading remains valid until the load increases to some 2.8 times the preload applied.

## 1-11 Designing Accuracy

### 1-11-1 Accuracy Standards

The accuracy of Linear Guide is stipulated for each type with regard to dimensional tolerances for running parallelism, height, and width; height difference among Linear Guide blocks installed on the same plane and differences in the rail-to-block lateral distance among Linear Guide blocks installed on the same rail. For details, see the standards tables for the models in question.

#### Running parallelism

When an Linear Guide block runs on a Linear Guide rail bolted to the reference base, if the Linear Guide block reference surface is not fully parallel to the Linear Guide rail reference surface over the entire length of the rail, the two members have insufficient running parallelism.

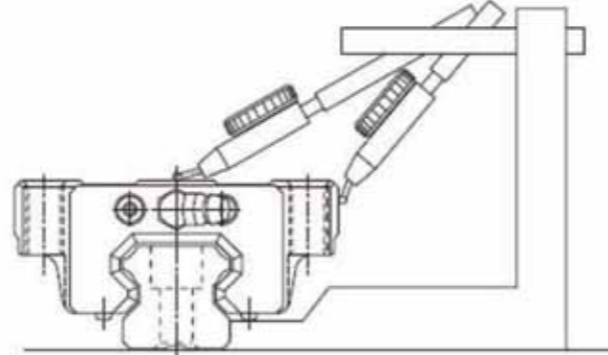

Fig1.11.1 Running parallelism

#### Difference in height M among Linear Guide blocks

This refers to the difference between the maximum and minimum height (M) of by any Linear Guide block installed on the same plane.

#### Difference in rail-to-block lateral distance W2 among Linear Guide blocks

This refers to the difference between the maximum and minimum rail-to-block lateral distance (W2) of by any Linear Guide block installed on a Linear Guide rail.

#### Note.1

With two or more sets of Linear Guide installed in parallel on the same plane, the tolerances for the rail-to-block lateral distance (W2) and the differences therein among Linear Guide blocks apply to the master – rail side only.

#### Note.2

Accuracy measurements indicate mean values of measurements taken at the center or central area of each Linear Guide block.

#### Note.3

Linear Guide rails are smoothly curved so that when they are installed on a machine they are easily straightened, and pressing them onto the machine reference base enables the design accuracy to be achieved. If installed on a base lacking rigidity, such as an aluminum base, the bend of Linear Guide rails may affect machine precision. In such a case, the straightness should be set in advance.

### 1-11-2 Averaging Effect

The Linear Guide incorporates precision balls with high sphericity, enabling a constrained structure to be created with no clearance. Moreover, in a multiple-axis configuration with the axes arranged in parallel to one another, the component Linear Guides therein combine to form an entire constrained guideway.

That is the misalignment of the machine base on which the Linear Guides are installed can be averaged and absorbed by the constrained structure, regardless of the misalignment – incomplete straightness levelness, and parallelism due to errors in machining and assembly of the machine base. The extent of the averaging effect varies with the degree of misalignment, i.e., errors in length and other dimensions the magnitude of the Linear Guide preload, and the number of axes constrained Fig.1 shows measurements of the motion accuracy of the table shown in Fig.2 ( perpendicularity in the lateral direction), which were taken by performing arbitrary misalignment of either of the two rails of the table. The averaging effect illustrated above makes it easier to create a guideway with a high degree of motion accuracy.

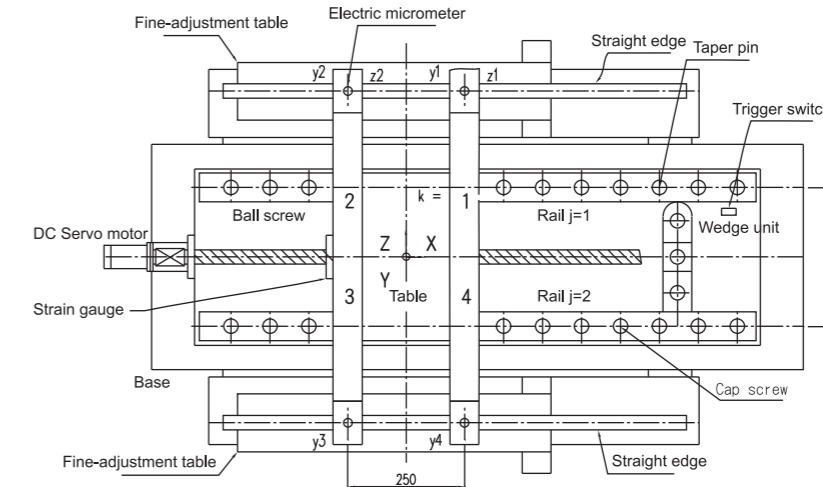

Fig1.11.2

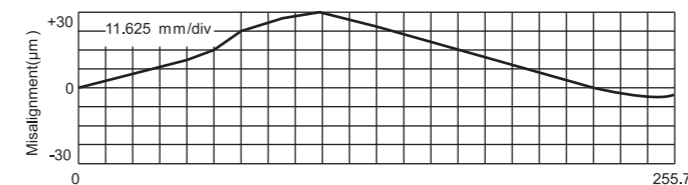

Fig1.11.3 Misalignment profile

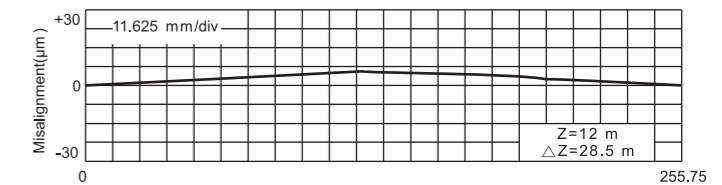

Fig1.11.4 Horizontal displacement of the table

## 1-12 Lubrication

### Lubrication

For long-term use of a linear motion system under normal conditions, good lubrication is a must. If lubricant is not used, rolling parts wear quickly, and the service life of the system is shortened considerably.

A lubricant :

- (1) Reduces friction on moving parts, thereby preventing seizure and lessening wear.
- (2) Forms an oil film on rolling surfaces, thus decreasing stress that develops on the surfaces and safeguarding the system against rolling fatigue.
- (3) Covers metal surfaces with an oil film, thereby preventing rust.

To tap the full functionality of a linear motion system, it is essential to provide lubrication that best meets the system service conditions.

Note: That linear motion systems, even if sealed, cannot completely eliminate leakage of lubricants no matter how negligible the amount of leakage is at any given time. It is therefore necessary to replenish the lubricant periodically according to the operating conditions for the lubricant in question.

### Classification of Lubricants

Primarily grease and sliding surface oil are used as lubricants for linear motion systems.

In general a lubricant must:

- |                                      |  |
|--------------------------------------|--|
| (1) Form a strong oil film.          | (5) Be noncorrosive.   |
| (2) Reduce wear as much as possible. | (6) Be highly rust-preventive.   |
| (3) Have high wear resistance.       | (7) Be free from dust and some moisture.   |
| (4) Have high thermal stability.     | (8) Be free from significant fluctuations in consistency against repeated agitation of grease. |

Table 1.12.1 Lubricants in General Use

Lubricant	Classification	Item
Grease	Lithium-based grease (JS No.2)	* 4FB Grease (TBI MOTION) Albania Grease No.2 (Showa Shell Sekiyu)
	Urea-base grease (JS No.2)	Daphne Eponex Grease No.2 (Idemitsu Kosan) or equivalent.
Oil	Sliding surface oil or turbine oil ISOVG32~68	Super Multi 32 to 68 (Idemitsu Kosan) Vactra No.2S (Mobile Oil) DT Oil (Mobile Oil) Tonner Oil (Showa Shell Sekiyu) or equivalent

※ Feeding Should be performed every 100km of travel under normal usage conditions to prevent incomplete lubrication by exhausted lubrication. ※

## 1-13 Precautions of Linear Guideway

### Handling

- (1) Tilting the linear guideway may cause the carriage falling out from the rail by their own weight.
- (2) Beating or Dropping the linear guideway may cause its function to be damage, even if the product looks intact.
- (3) Do not disassemble the carriage, this may cause contamination to enter into the carriage or decrease the installation accuracy.

### Lubrication

- (1) Please remove the anti-rust oil.
- (2) Please do not mix different kinds of lubrication.
- (3) Lubrication can be varied, please contact **TBI MOTION** before use.

### Usage

- (1) The temperature of the place where linear guideways are used should not exceed 80°C. A higher temperature may damage the plastic end cap, do not exceed 100°C in friction.
- (2) Using under special conditions, such as constant vibration, high dust or the temperature exceed our suggested...etc., please contact .

### Storage

When storing the linear guideway, enclose it in a package and store it in a horizontal orientation while avoiding high temperature, low temperature and high humidity.



## 2-1 The Characteristics of TBI Linear Guide

### TBI MOTION The Characteristics of TR Series

#### Smooth Movement

TBI MOTION The circulation system of TBI Linear Guide Block designed to perform smooth movement.

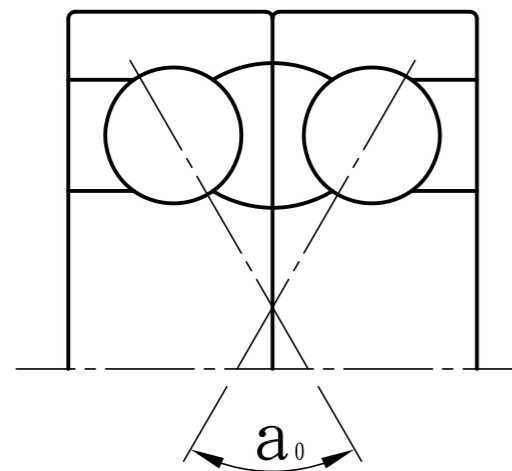

Fig2.1.1

#### High Stability

TBI MOTION Linear Guide block designed under TBI's exclusive patent can increase depth of material to improve the strength capacity and prevent from deflection as high stability.

#### High Durability

TBI MOTION The exclusive contact point design promotes high rigidity. Moreover, self-aligning balances load rating in all directions. This design also improves performance in running accuracy and service life of the Linear Guide.

#### Easy Installation with Interchangeability

TBI MOTION Linear Guide by TBI is easy for installation even without fixture. The design of seal is combinable either for side seal or inner seal to save material.

## 2-2 The Structure of TR-series

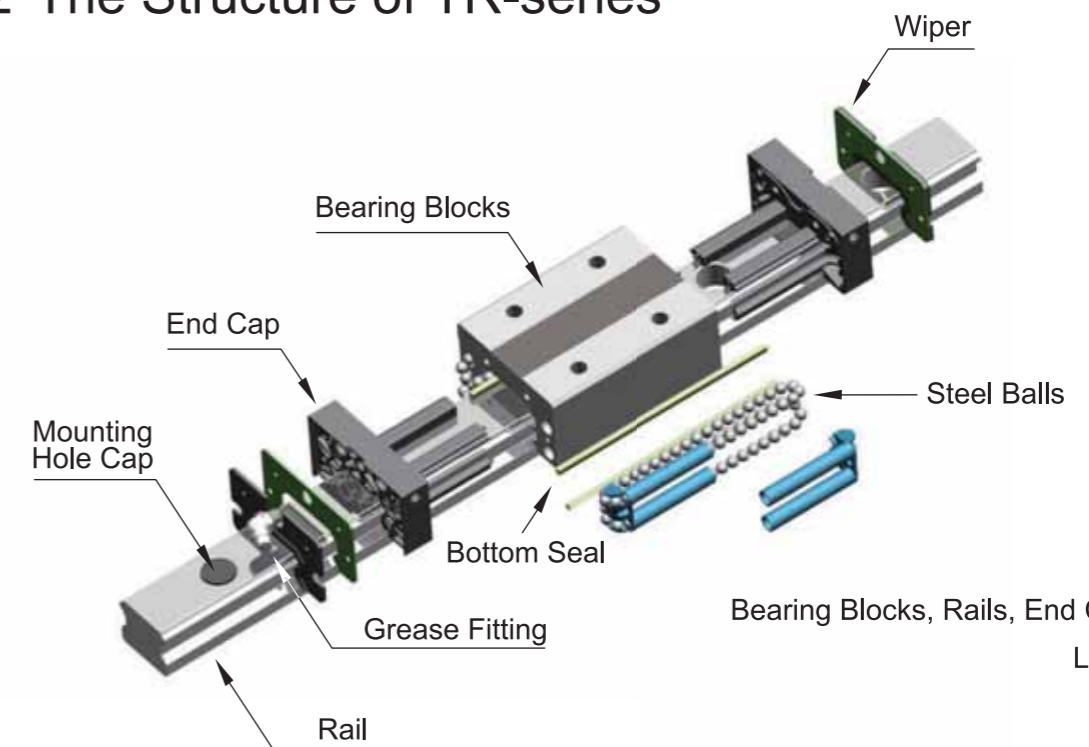

Fig2.2.1 Wiper, Top and Bottom Seal, Mounting Hole Cap.

Circulation unit :

Bearing Blocks, Rails, End Cap, Steel Balls.

Lubrication unit :

Grease Fitting.

Anti-Dust Unit :

## 2-3 Accessories for extreme operating conditions

for extreme operation usage or custom design.

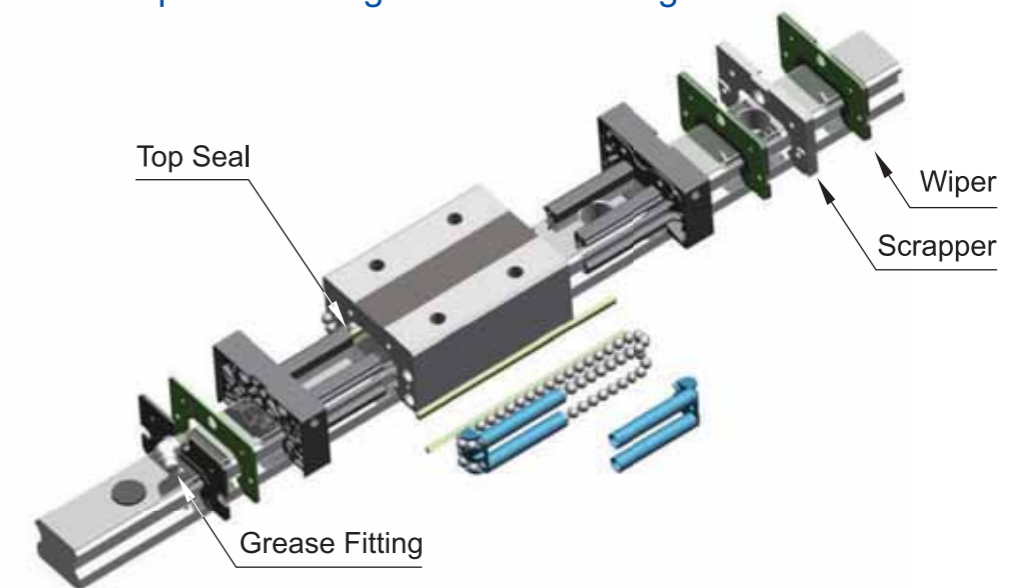

Fig2.3.1

U : Wiper, Top Seal, Bottom Seal.

UZ : Dual-Wiper, Top Seal, Bottom seal.



## 2-4 TR-SERIES

(Block types)

TBI MOTION offers flange and square types of flange. The assembly height and category lists as below :

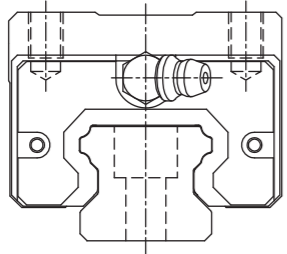
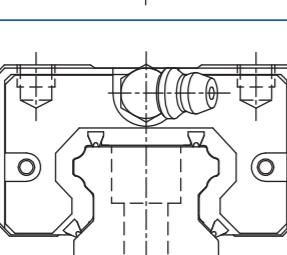
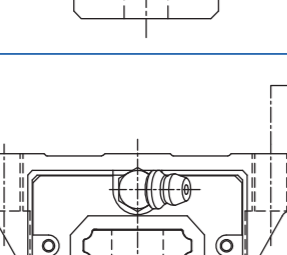
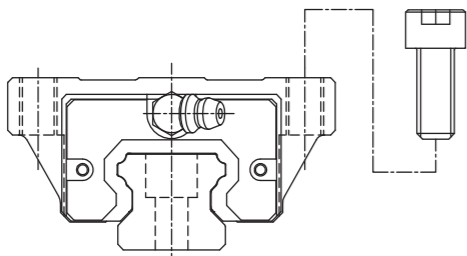
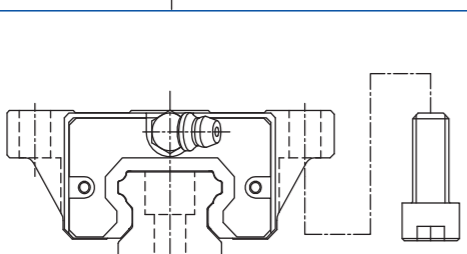
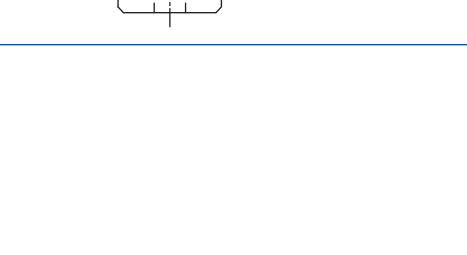
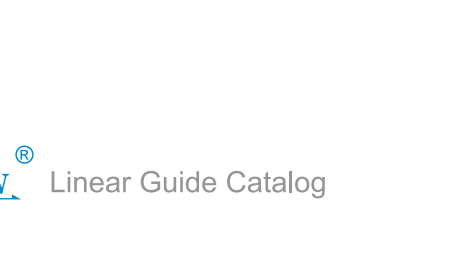
Type	Model	Shape	Height	Rail Length	Main Application
Square	TRH-V		28	100	<ul style="list-style-type: none"> <li>Machine Centers.</li> <li>NC Lathes.</li> <li>Food Machine.</li> <li>Grinding Machines.</li> <li>CNC Machine.</li> <li>Heavy Cutting Machines.</li> <li>Punching Machine.</li> <li>Injection Molding Machine.</li> <li>Automation Equipment.</li> <li>Transportation Equipment.</li> <li>Sealing machine.</li> </ul>
	TRH-C		90	4000	
	TRS-V		24	100	
Flange	TRH-F		24	100	
	TRH-F		90	4000	
	TRS-F		24	100	
TRS-F		60	4000		

## 2-5 Model Number for TR Rails

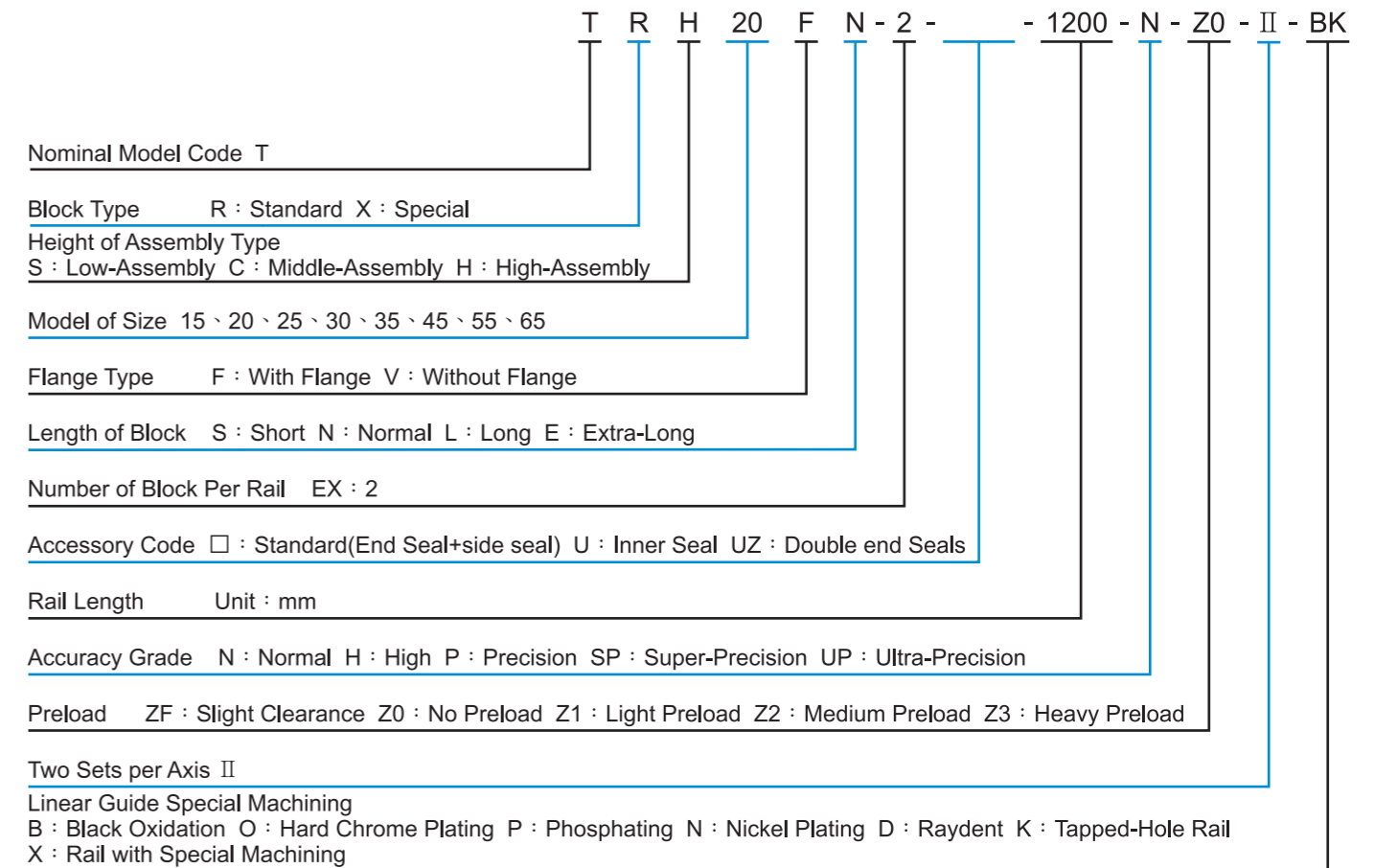

## TRH - V Series Dimension Table

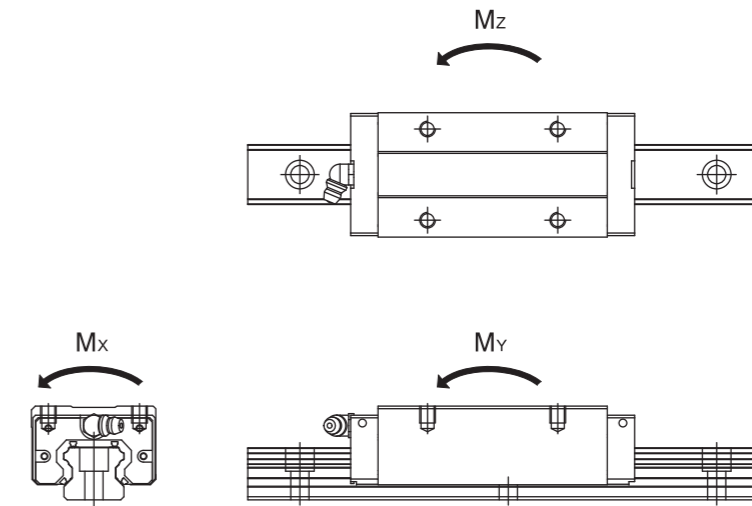
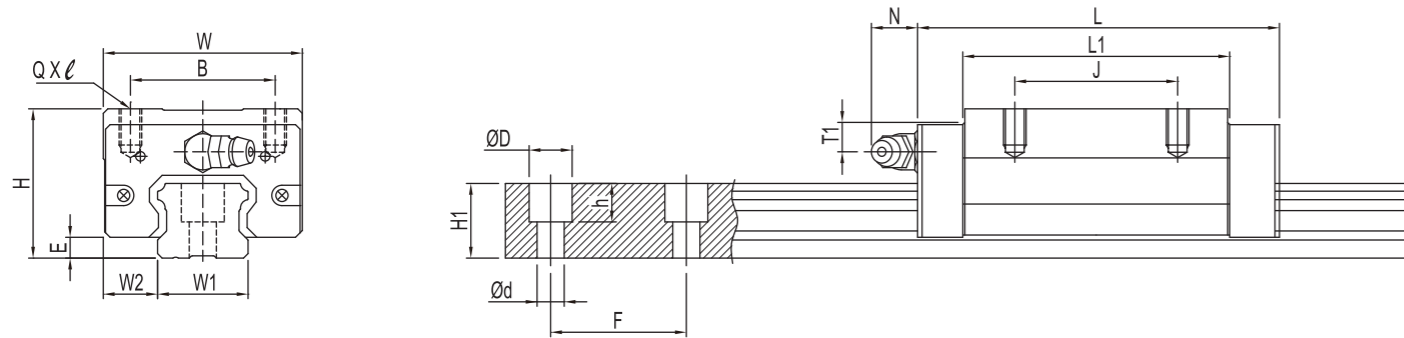

Model No.	Assembly(mm)			Block(mm)									Rail(mm)					
	H	W2	E	W	B	J	L	L1	QXl	T1	Oil Hole	N	W1	H1	φD	h	φd	F
TRH15VN	28	9.5	3.2	34	26	26	55.9	39.5	M4X5	9.5	M4X0.7	7	15	13	7.5	6	4.5	60
TRH15VL							64.4	48										
TRH20VN	30	12	4.6	44	32	36	74	54	M5X5	6.5	M6X1	14	20	16.5	9.5	8.5	6	60
TRH20VL							79	59										
TRH20VE							50	98										
TRH25VN	40	12.5	5.8	48	35	35	80	59	M6X8	11.5	M6X1	14	23	20	11	9	7	60
TRH25VL							92	71										
TRH25VE							50	109										
TRH30VN	45	16	7	60	40	40	95.3	69.3	M8X10	11	M6X1	14	28	23	14	12	9	80
TRH30VL							106	80										
TRH30VE							60	131										
TRH35VN	55	18	7.5	70	50	50	108	79	M8X10	15	M6X1	14	34	26	14	12	9	80
TRH35VL							122	93										
TRH35VE							72	152										
TRH45VL	70	20.5	8.9	86	60	60	140	106	M10X15	20.5	PT1/8	12.5	45	32	20	17	14	105
TRH45VE						80	174	140										
TRH55VL	80	23.5	13	100	75	75	163	118	M12X18	21	PT1/8	12.5	53	44	23	20	16	120
TRH55VE						95	201.1	156.1										
TRH65VL	90	31.5	14	126	76	70	197	147	M16X20	19	PT1/8	12.5	63	53	26	22	18	150
TRH65VE						120	256.5	206.5										

Model No.	Rating Load (kgf)		Static permissible moment of load					Weight	
	C	Co	Mx(kgf-mm)	My(kgf-mm)		Mz(kgf-mm)		Block (kg)	Rail (kg/m)
			Single Block	Single Block	Double Block	Single Block	Double Block		
TRH15VN	1206	2206	16,436	14,884	70,960	14,884	70,960	0.13	1.32
TRH15VL	1343	2574	19,175	20,429	95,224	20,429	95,224	0.2	
TRH20VN	2050	3696	37,334	33,268	157,298	33,268	157,298	0.26	2.28
TRH20VL	2125	3891	39,299	36,965	176,924	36,965	176,924	0.29	
TRH20VE	2553	5058	51,089	63,229	284,163	63,229	284,163	0.38	
TRH25VN	2581	4503	52,239	43,407	207,324	43,407	207,324	0.54	3.17
TRH25VL	2875	5254	60,945	59,579	277,678	59,579	277,678	0.55	
TRH25VE	3248	6255	72,554	85,112	391,311	85,112	391,311	0.68	
TRH30VN	3807	6483	90,722	74,970	355,321	74,970	355,321	0.76	4.54
TRH30VL	4098	7203	100,803	93,100	438,966	93,100	438,966	0.85	
TRH30VE	4791	9004	126,003	147,000	677,068	147,000	677,068	1.12	
TRH35VN	5090	8346	142,722	106,070	519,799	106,070	519,799	1.31	6.27
TRH35VL	5502	9328	159,512	133,367	656,509	133,367	656,509	1.52	
TRH35VE	6667	12274	209,885	233,977	1,070,533	233,977	1,070,533	2	
TRH45VL	7572	12808	292,657	220,751	1,030,183	220,751	1,030,183	2.7	10.4
TRH45VE	8852	16010	365,821	348,554	1,598,703	348,554	1,598,703	3.58	
TRH55VL	14703	21613	571,342	411,729	2,019,184	411,729	2,019,184	3.60	
TRH55VE	17349	27377	723,699	670,530	3,148,637	670,530	3,148,637	4.70	16.1
TRH65VL	22526	31486	973,074	695,840	3,594,277	695,840	3,594,277	7.76	
TRH65VE	27895	42731	1,320,601	1,307,568	6,312,759	1,307,568	6,312,759	11.15	

## TRH - F Series Dimension Table

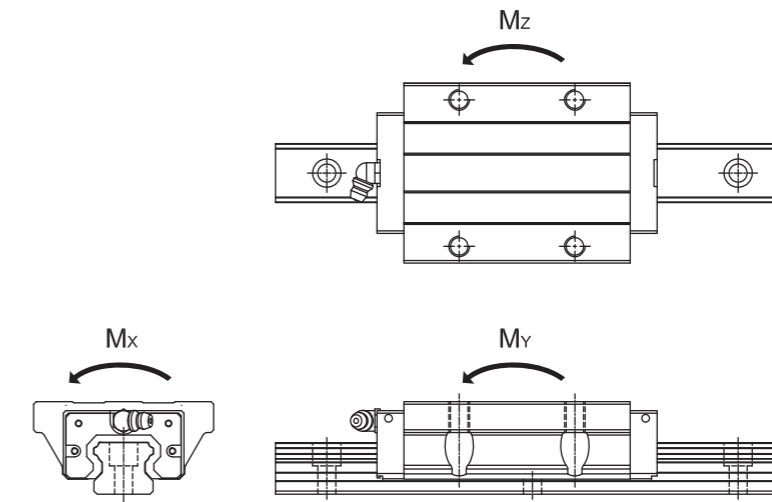
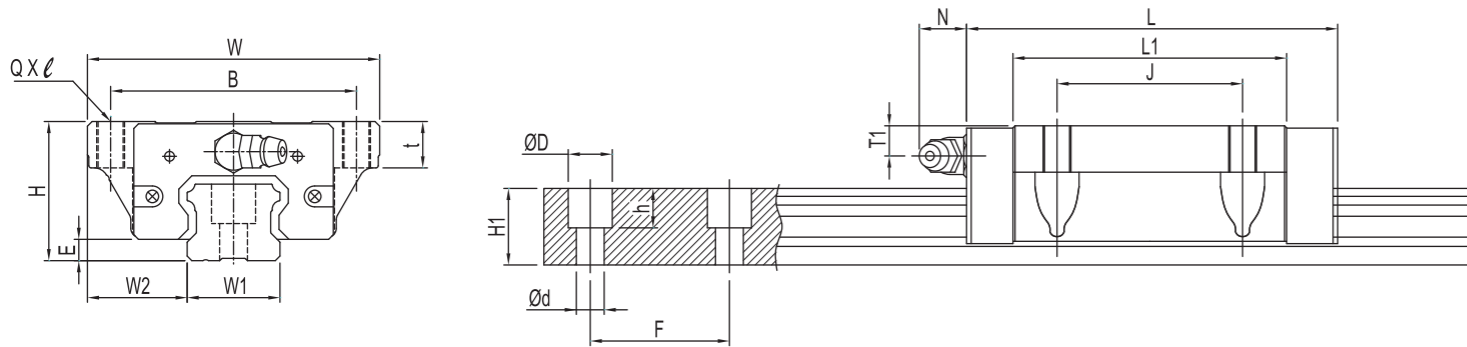

Model No.	Assembly(mm)			Block(mm)										Rail(mm)						
	H	W2	E	W	B	J	t	L	L1	QXl	T1	Oil Hole	N	W1	H1	ØD	h	Ød	F	
TRH15FN								55.9	39.5											
TRH15FL	24	16	3.2	47	38	30	8	64.4	48	M5X8	5.5	M4X0.7	7	15	13	7.5	6	4.5	60	
TRH15FE								79.4	63											
TRH20FN								74	54											
TRH20FL	30	21.5	4.6	63	53	40	10	79	59	M6X10	6.5	M6X1	14	20	16.5	9.5	8.5	6	60	
TRH20FE								98	78											
TRH25FN								80	59											
TRH25FL	36	23.5	5.8	70	57	45	12	92	71	M8X12	7.5	M6X1	14	23	20	11	9	7	60	
TRH25FE								109	88											
TRH30FN								95.3	69.3											
TRH30FL	42	31	7	90	72	52	15	106	80	M10X15	8	M6X1	14	28	23	14	12	9	80	
TRH30FE								131	105											
TRH35FN								108	79											
TRH35FL	48	33	7.5	100	82	62	15	122	93	M10X15	8	M6X1	14	34	26	14	12	9	80	
TRH35FE								152	123											
TRH45FL	60	37.5	8.9	120	100	80	18	140	106	M12X18	10.5	PT1/8	12.5	45	32	20	17	14	105	
TRH45FE								174	140											
TRH55FL	70	43.5	13	140	116	95	29	163	118	M14X17	11	PT1/8	12.5	53	44	23	20	16	120	
TRH55FE								201.1	156.1											
TRH65FL	90	53.5	14	170	142	110	37	197	147	M16X23	19	PT1/8	12.5	63	53	26	22	18	150	
TRH65FE								256.5	206.5											

Model No.	Rating Load (kgf)		Static permissible moment of load					Weight	
	C	Co	Mx(kgf-mm)	My(kgf-mm)		Mz(kgf-mm)		Block (kg)	Rail (kg/m)
			Single Block	Single Block	Double Block	Single Block	Double Block		
TRH15FN	1206	2206	16,436	14,884	70,960	14,884	70,960	0.17	1.32
TRH15FL	1343	2574	19,175	20,429	95,224	20,429	95,224	0.2	
TRH15FE	1560	3187	23,740	31,616	145,220	31,616	145,220	0.26	
TRH20FN	2050	3696	37,334	33,268	157,298	33,268	157,298	0.36	2.28
TRH20FL	2125	3891	39,299	36,965	176,924	36,965	176,924	0.4	
TRH20FE	2553	5058	51,089	63,229	284,163	63,229	284,163	0.53	
TRH25FN	2581	4503	52,239	43,407	207,324	43,407	207,324	0.54	3.17
TRH25FL	2875	5254	60,945	59,579	277,678	59,579	277,678	0.62	
TRH25FE	3248	6255	72,554	85,112	391,311	85,112	391,311	0.78	
TRH30FN	3807	6483	90,722	74,970	355,321	74,970	355,321	1.31	4.54
TRH30FL	4098	7203	100,803	93,100	438,966	93,100	438,966	1.42	
TRH30FE	4791	9004	126,003	147,000	677,068	147,000	677,068	1.77	
TRH35FN	5090	8346	142,722	106,070	519,799	106,070	519,799	1.36	6.27
TRH35FL	5502	9328	159,512	133,367	656,509	133,367	656,509	1.58	
TRH35FE	6667	12274	209,885	233,977	1,070,533	233,977	1,070,533	2.11	
TRH45FL	7572	12808	292,657	220,751	1,030,183	220,751	1,030,183	2.66	10.4
TRH45FE	8852	16010	365,821	348,554	1,598,703	348,554	1,598,703	3.55	
TRH55FL	14703	21613	571,342	411,729	2,019,184	411,729	2,019,184	3.62	
TRH55FE	17349	27377	723,699	670,530	3,148,637	670,530	3,148,637	4.71	16.1
TRH65FL	22526	31486	973,074	695,840	3,594,277	695,840	3,594,277	7.96	
TRH65FE	27895	42731	1,320,601	1,307,568	6,312,759	1,307,568	6,312,759	11.35	

## TRS - V Series Dimension Table

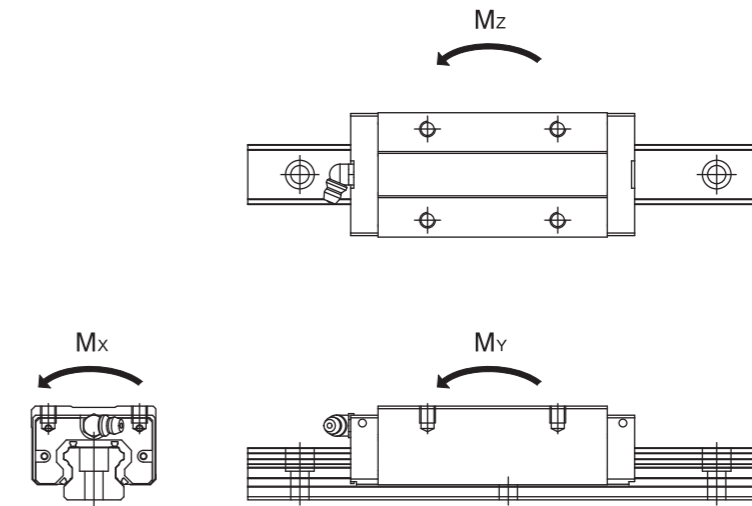
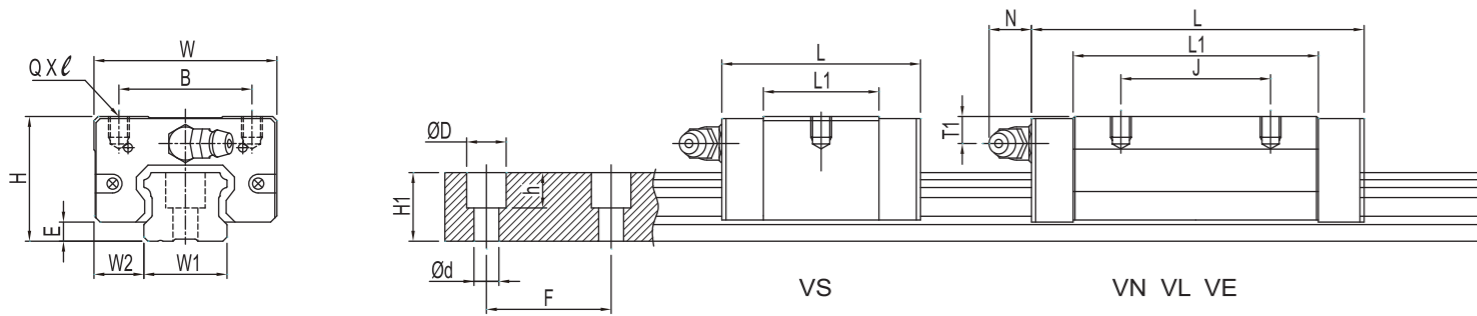

Model No.	Assembly(mm)			Block(mm)									Rail(mm)					
	H	W2	E	W	B	J	L	L1	QXl	T1	Oil Hole	N	W1	H1	ØD	h	Ød	F
TRS15VS	24	9.5	3.2	34	26	39.3	22.9	M4X5	5.5	M4X0.7	7	15	13	7.5	6	4.5	60	
TRS15VN						26	55.9											39.5
TRS15VL						26	64.4											48
TRS15VE						34	79.4											63
TRS20VS	28	11	4.6	42	32	47.8	27.8	M5X5	4.5	M6X1	14	20	16.5	9.5	8.5	6	60	
TRS20VN						32	66.7											46.7
TRS25VS	33	12.5	5.8	48	35	56.2	35.2	M6X6	4.5	M6X1	14	23	20	11	9	7	60	
TRS25VN						35	80											59
TRS30VS	42	16	7	60	40	66.4	40.4	M8X8	8	M6X1	14	28	23	14	12	9	80	
TRS30VN						40	95.3											69.3
TRS30VL						40	106											80
TRS30VE						60	131											105
TRS35VS	48	18	7.5	70	50	74.7	45.7	M8X8	8	M6X1	14	34	26	14	12	9	80	
TRS35VN						50	108											79
TRS35VL						50	122											93
TRS35VE						72	152											123
TRS45VN	60	20.5	8.9	86	60	60	124.5	90.5	M10X15	10.5	PT1/8	12.5	45	32	20	17	14	105
TRS45VL						60	140	106										
TRS45VE						80	174	140										

Model No.	Rating Load (kgf)		Static permissible moment of load					Weight	
	C	Co	Mx(kgf-mm)	My(kgf-mm)		Mz(kgf-mm)		Block (kg)	Rail (kg/m)
			Single Block	Single Block	Double Block	Single Block	Double Block		
TRS15VS	908	1471	10,957	6,420	33,531	6,420	33,531	0.07	1.32
TRS15VN	1206	2206	16,436	14,884	70,960	14,884	70,960	0.13	
TRS15VL	1343	2574	19,175	20,429	95,224	20,429	95,224	0.15	
TRS15VE	1560	3187	23,740	31,616	145,220	31,616	145,220	0.2	
TRS20VS	1398	2140	21,615	10,700	59,798	10,700	59,798	0.11	2.28
TRS20VN	1896	3307	33,404	26,459	126,998	26,459	126,998	0.18	
TRS25VS	1943	3002	34,826	18,725	97,890	18,725	97,890	0.18	3.17
TRS25VN	2581	4503	52,239	43,407	207,324	43,407	207,324	0.3	
TRS30VS	2697	3962	55,442	26,950	154,224	26,950	154,224	0.37	4.54
TRS30VN	3807	6483	90,722	74,970	355,321	74,970	355,321	0.65	
TRS30VL	4098	7203	100,803	93,100	438,966	93,100	438,966	0.74	
TRS30VE	4791	9004	126,003	147,000	677,068	147,000	677,068	0.97	
TRS35VS	3753	5401	92,349	42,896	235,304	42,896	235,304	0.57	6.27
TRS35VN	5090	8346	142,722	106,070	519,799	106,070	519,799	0.98	
TRS35VL	5502	9328	159,512	133,367	656,509	133,367	656,509	1.16	
TRS35VE	6667	12274	209,885	233,977	1,070,533	233,977	1,070,533	1.54	
TRS45VN	6758	10887	248,758	158,011	782,271	158,011	782,271	1.71	10.4
TRS45VL	7572	12808	292,657	220,751	1,030,183	220,751	1,030,183	1.99	
TRS45VE	8852	16010	365,821	348,554	1,598,703	348,554	1,598,703	2.64	



## TRS - F Series Dimension Table

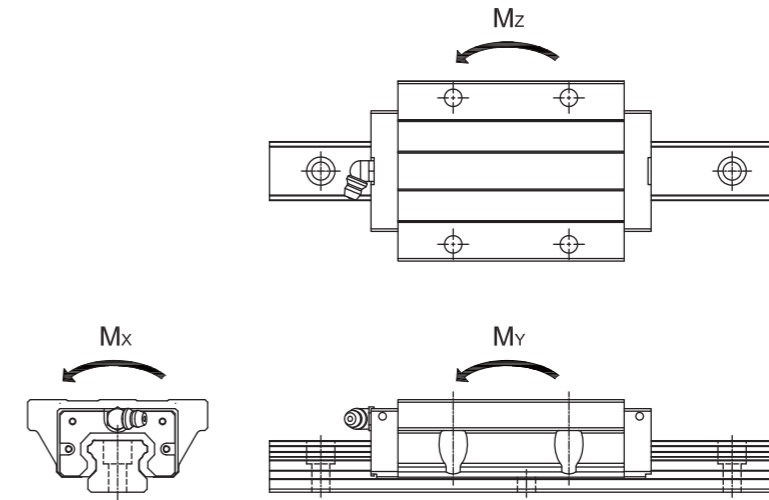
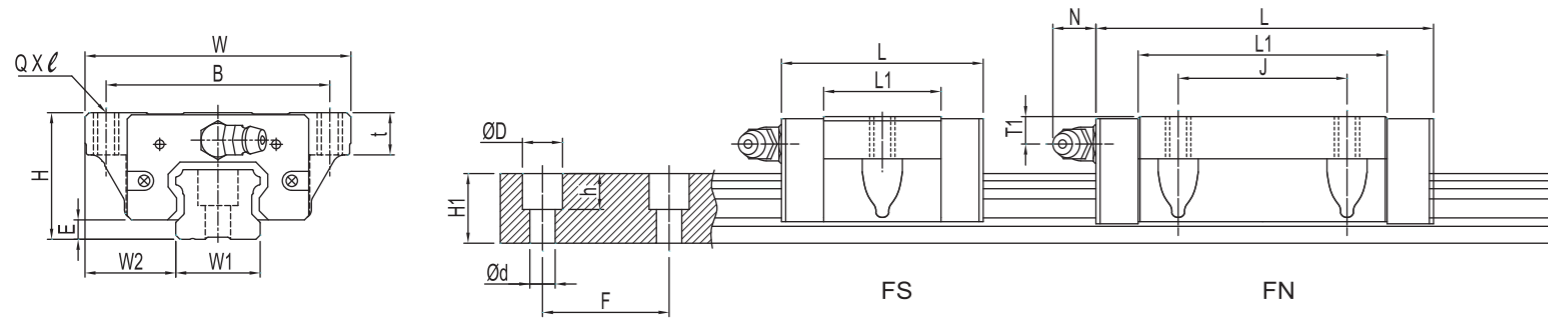

Model No.	Assembly(mm)			Block(mm)										Rail(mm)					
	H	W2	E	W	B	J	t	L	L1	QXl	T1	Oil Hole	N	W1	H1	φD	h	φd	F
TRS15FS	24	18.5	3.2	52	41	26	7	39.3	22.9	M5X7	5.5	M4X0.7	7	15	13	7.5	6	4.5	60
TRS15FN								55.9	39.5										
TRS20FS	28	19.5	4.6	59	49	32	9	47.8	27.8	M6X9	4.5	M6X1	14	20	16.5	9.5	8.5	6	60
TRS20FN								66.7	46.7										
TRS25FS	33	25	5.8	73	60	35	10	56.2	35.2	M8X10	4.5	M6X1	14	23	20	11	9	7	60
TRS25FN								80	59										
TRS30FS	42	31	7	90	72	40	10	66.4	40.4	M10X10	8	M6X1	14	28	23	14	12	9	80
TRS30FN								95.3	69.3										
TRS35FS	48	33	7.5	100	82	50	13	74.7	45.7	M10X13	8	M6X1	14	34	26	14	12	9	80
TRS35FN								108	79										
TRS45FN	60	37.5	8.9	120	100	60	15	124.5	90.5	M12X15	10.5	PT1/8	12.5	45	32	20	17	14	105

Model No.	Rating Load (kgf)		Static permissible moment of load					Weight	
	C	Co	Mx(kgf-mm)	My(kgf-mm)		Mz(kgf-mm)		Block (kg)	Rail (kg/m)
			Single Block	Single Block	Double Block	Single Block	Double Block		
TRS15FS	908	1471	10,957	6,420	33,531	6,420	33,531	0.098	1.32
TRS15FN	1206	2206	16,436	14,884	70,960	14,884	70,960	0.17	
TRS20FS	1398	2140	21,615	10,700	59,798	10,700	59,798	0.15	2.28
TRS20FN	1896	3307	33,404	26,459	126,998	26,459	126,998	0.24	
TRS25FS	1943	3002	34,826	18,725	97,890	18,725	97,890	0.26	3.17
TRS25FN	2581	4503	52,239	43,407	207,324	43,407	207,324	0.44	
TRS30FS	2697	3962	55,442	26,950	154,224	26,950	154,224	0.52	4.54
TRS30FN	3807	6483	90,722	74,970	355,321	74,970	355,321	0.88	
TRS35FS	3753	5401	92,349	42,896	235,304	42,896	235,304	0.76	6.27
TRS35FN	5090	8346	142,722	106,070	519,799	106,070	519,799	1.31	
TRS45FN	6758	10887	248,758	158,011	782,271	158,011	782,271	2.18	10.35

## TRC - V Series Dimension Table

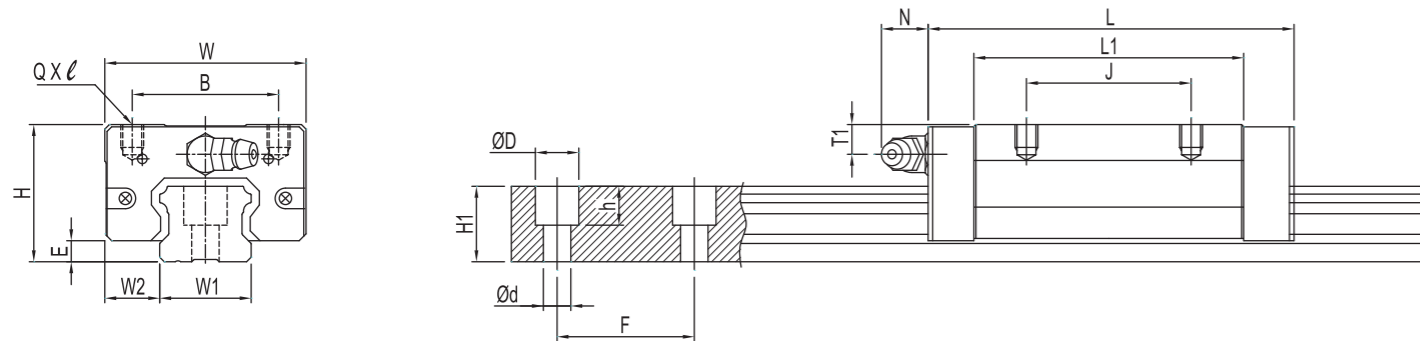

Model No.	Assembly(mm)			Block(mm)									Rail(mm)					
	H	W2	E	W	B	J	L	L1	QXl	T1	Oil Hole	N	W1	H1	φD	h	φd	F
TRC25VL	36	12.5	5.8	48	35	35	92	71	M6X6.5	7.5	M6X1	14	23	20	11	9	7	60
TRC25VE						50	109	88										

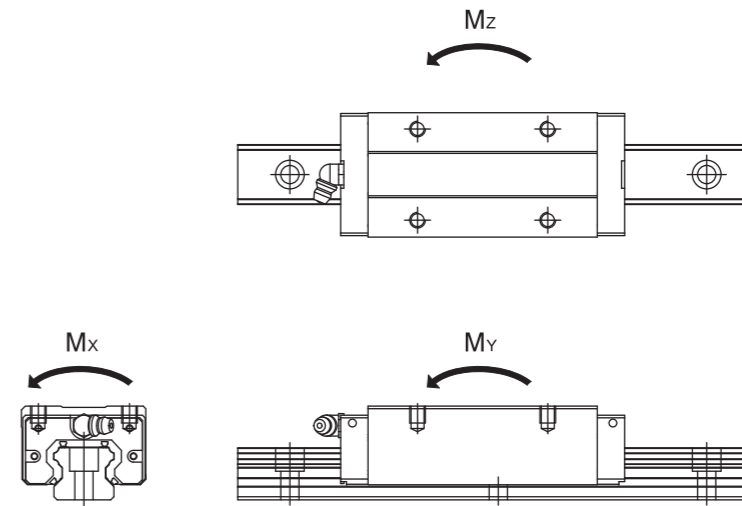

Model No.	Rating Load (kgf)		Static permissible moment of load					Weight	
	C	Co	Mx(kgf-mm)	My(kgf-mm)		Mz(kgf-mm)		Block (kg)	Rail (kg/m)
			Single Block	Single Block	Double Block	Single Block	Double Block		
TRC25VL	2875	5254	60,945	59,579	277,678	59,579	277,678	0.44	3.17
TRC25VE	3248	6255	72,554	85,112	391,311	85,112	391,311		



## TM - N Series Dimension Table

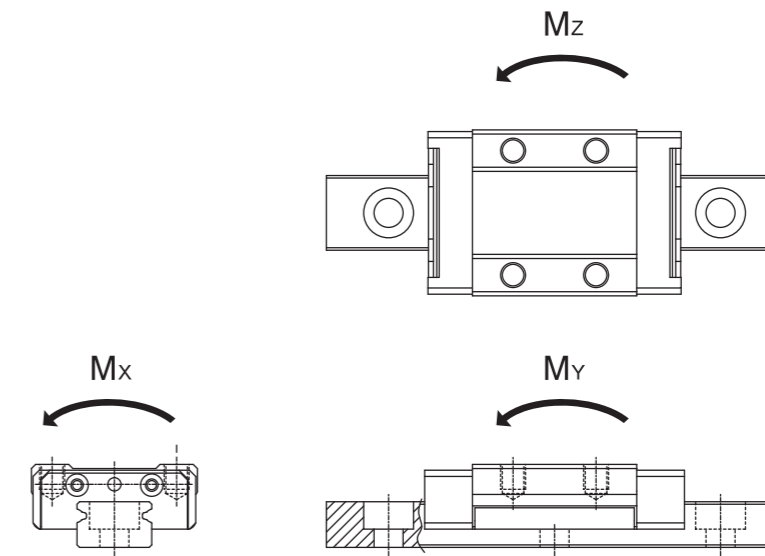
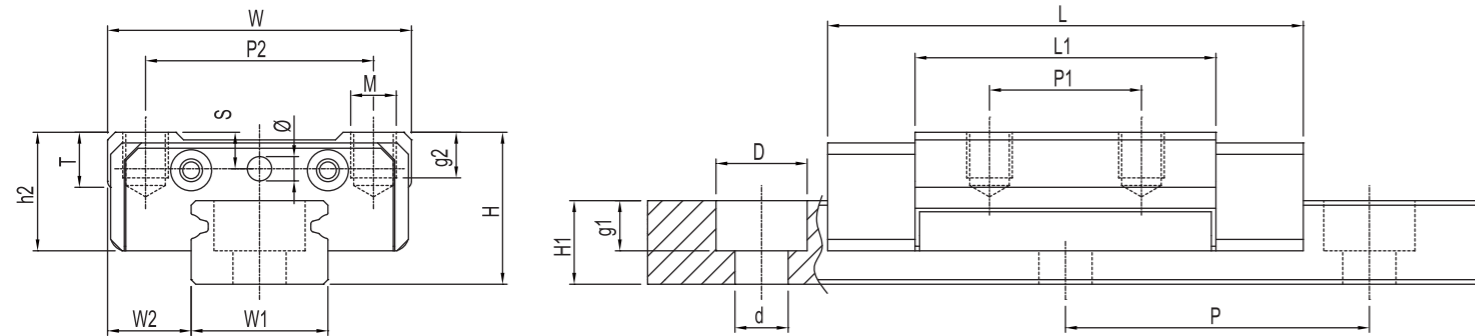

Model No.	Assembly (mm)		Block(mm)						Rail(mm)										
	H	W2	W1	H1	P	D	d	g1	W	L	L1	h2	P1	P2	M	g2	T	$\phi$	S
TM07NN	8	5	7	4.7	15	4.2	2.4	2.3	17	23	12.3	6.5	8	12	M2	2	2.25	1.3	1.5
TM07NL	8	5	7	4.7	15	4.2	2.4	2.3	17	31	20.3	6.5	13	12	M2	2	2.25	1.3	1.5
TM09NN	10	5.5	9	5.5	20	6	3.5	3.3	20	30.5	19.8	7.8	10	15	M3	3	3.62	1.3	2.4
TM09NL	10	5.5	9	5.5	20	6	3.5	3.3	20	40.8	30.1	7.8	16	15	M3	3	3.62	1.3	2.4
TM12NN	13	7.5	12	7.5	25	6	3.5	4.5	27	35	20.6	10	15	20	M3	3.5	4.54	1.3	3
TM12NL	13	7.5	12	7.5	25	6	3.5	4.5	27	47.5	33.1	10	20	20	M3	3.5	4.54	1.3	3
TM15NN	16	8.5	15	9.5	40	6	3.5	4.5	32	43	27	12	20	25	M3	5	5.86	1.3	3.3
TM15NL	16	8.5	15	9.5	40	6	3.5	4.5	32	60	44	12	25	25	M3	5	5.86	1.3	3.3

Model No.	Rating Load (kgf)		Static permissible moment of load					Weight	
			Mx(kgf-mm)	My(kgf-mm)		Mz(kgf-mm)		Block (kg)	Rail (kg/m)
	C	Co	Single Block	Single Block	Double Block	Single Block	Double Block		
TM07NN	144	204	745	232	3,234	232	3,234	0.005	0.21
TM07NL	220	374	1,367	849	7,261	849	7,261	0.009	
TM09NN	220	374	1,713	849	7,117	849	7,117	0.013	0.32
TM09NL	299	579	2,648	2,099	14,174	2,099	14,174	0.020	
TM12NN	381	536	3,269	1,094	12,391	1,094	12,391	0.024	0.61
TM12NL	555	919	5,604	3,437	26,857	3,437	26,857	0.039	
TM15NN	581	834	6,336	2,316	23,096	2,316	23,096	0.048	
TM15NL	860	1,459	11,088	7,527	52,908	7,527	52,908	0.080	1



## 2-8 Mounting Location

TBI MOTION offer our customer standard and customized rail length to meet the requirement for our customer. TBI suggest that when ordering customized rail length, to prevent unbalance running performance after mounting, the end cap value G should be no greater than 1/2P.

$$L = [n - 1] \cdot F + 2 \cdot G$$

L : Total length of rail (mm)

n : Number of mounting holes

F : Distance between any two holes (mm)

E : Distance from the center of the last hole to the edge (mm)

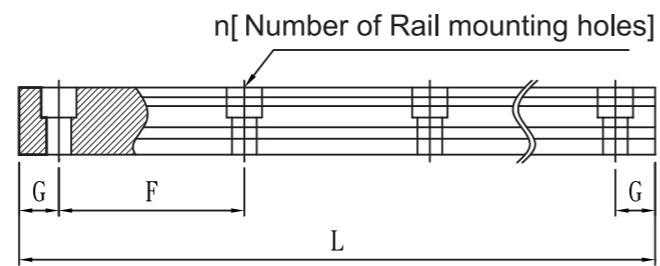

Fig2.8.1

Table.2.8.1

Item	TR15	TR20	TR25	TR30	TR35	TR45	TR55	TR65
F : Pitch	60	60	60	80	80	105	120	150
G : Distance to End	20	20	20	20	20	22.5	30	35
L : Max. Length	4000	4000	4000	4000	4000	4000	4000	4000

## 2-9 Type

Besides the standard top mounting type, **TBI MOTION** also offers bottom mounting type rails.

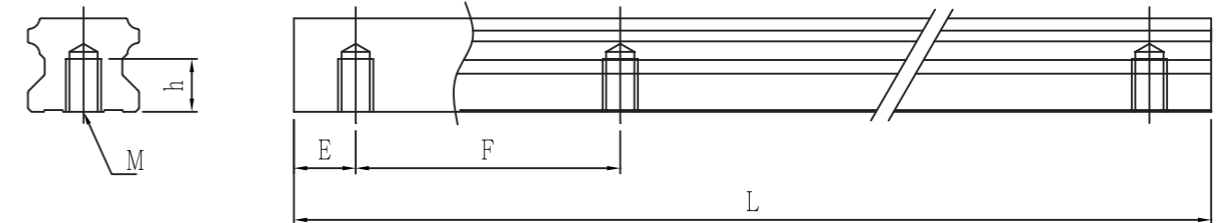
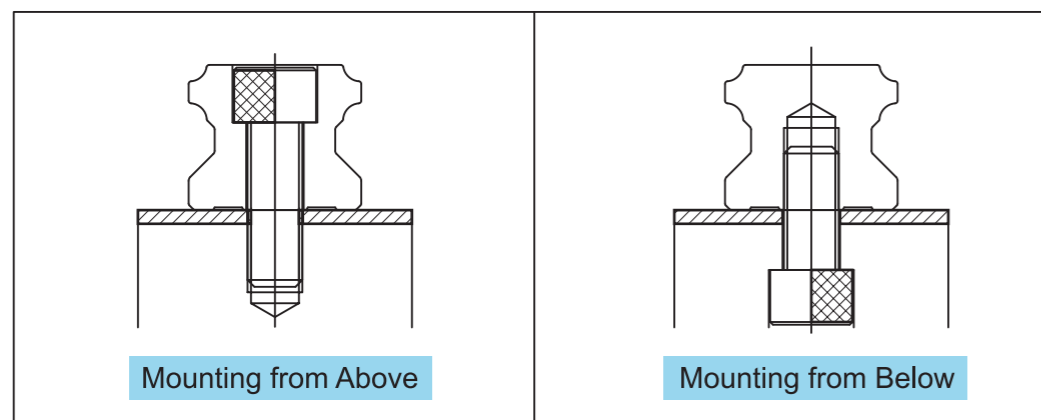

Fig2.8.2 Mounting from below

Table.2.8.2 Rail Size Chart

Unit : mm

	M	h	E	F
TR15	M5 · 0.8P	8	20	60
TR20	M6 · 1P	10	20	60
TR25	M6 · 1P	12	20	60
TR30	M8 · 1.25P	15	20	80
TR35	M8 · 1.25P	17	20	80
TR45	M12 · 1.75P	24	22.5	105
TR55	M14 · 2P	24	30	120
TR65	M20 · 2.5P	30	35	150

## 2-10 Accuracy Standard

The accuracy standards of TR-Series ranged, from normal, high, precision, super-precision and ultra-precision. It allows our user to choose according to the accuracy standards of the equipment.

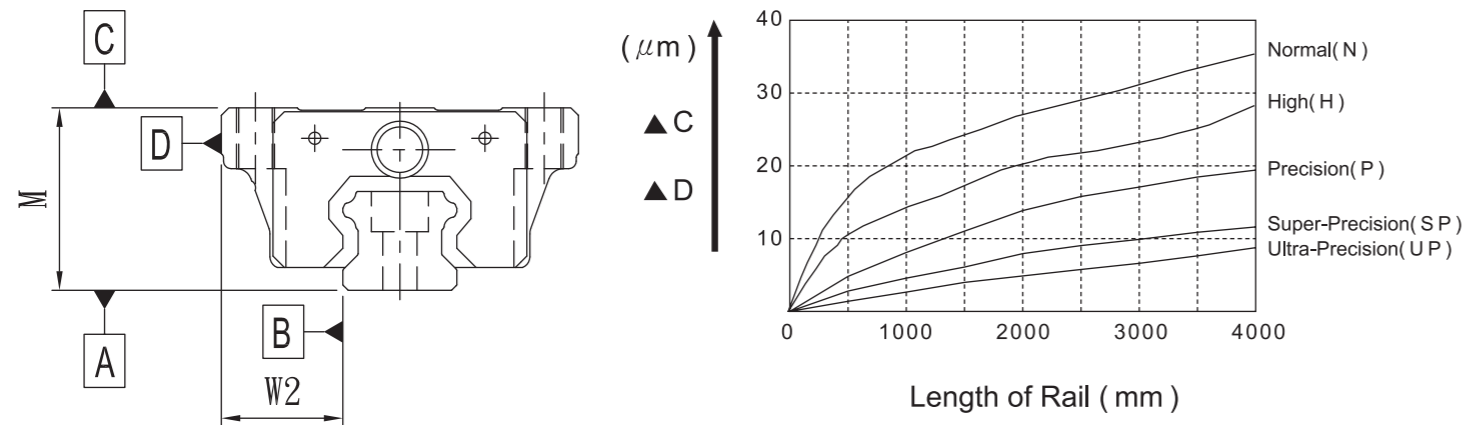
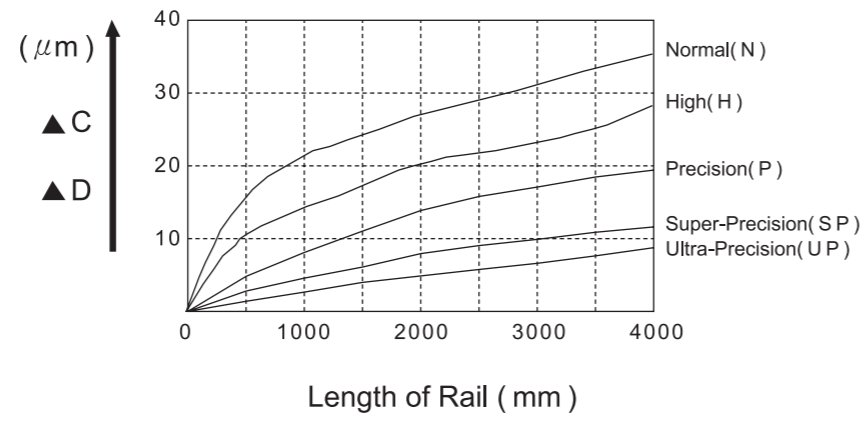

Fig2.10.1 Accuracy Standard



TR Rail Length and Running Accuracy.

Fig2.10.2

Table.2.10.1

Unit : mm

Accuracy Standard										
	TR 15 20					TR 25 30 35				
Accuracy Standard	Normal	High	Precision	Super Precision	Ultra Precision	Normal	High	Precision	Super Precision	Ultra Precision
Item	N	H	P	SP	UP	N	H	P	SP	UP
Tolerance for height M	±0.1	±0.03	0	0	0	±0.1	±0.04	0	0	0
Tolerance for height M difference among Linear Guide Block	0.02	0.01	0.006	0.004	0.003	0.02	0.015	0.007	0.005	0.003
Tolerance for rail-to-block lateral distance W2	±0.1	±0.03	0	0	0	±0.1	±0.04	0	0	0
Tolerance for rail-to-block lateral distance W2 difference among Linear Guide Block	0.02	0.01	0.006	0.004	0.003	0.03	0.015	0.007	0.005	0.003
Running parallelism of Linear Guide Block surface [C] with respect to surface [A]	△ C(TR Rail Length and Running Accuracy)					△ C(TR Rail Length and Running Accuracy)				
Running parallelism of Linear Guide Block surface [D] with respect to surface [B]	△ D(TR Rail Length and Running Accuracy)					△ D(TR Rail Length and Running Accuracy)				
	TR 45 55					TR 65				
Accuracy Standard	Normal	High	Precision	Super Precision	Ultra Precision	Normal	High	Precision	Super Precision	Ultra Precision
Item	N	H	P	SP	UP	N	H	P	SP	UP
Tolerance for height M	±0.1	±0.05	0	0	0	±0.1	±0.07	0	0	0
Tolerance for height M difference among Linear Guide Block	0.03	0.015	0.007	0.005	0.003	0.03	0.02	0.01	0.007	0.005
Tolerance for rail-to-block lateral distance W2	±0.1	±0.05	0	0	0	±0.1	±0.07	0	0	0
Tolerance for rail-to-block lateral distance W2 difference among Linear Guide Block	0.03	0.02	0.01	0.007	0.005	0.03	0.025	0.015	0.01	0.007
Running parallelism of Linear Guide Block surface [C] with respect to surface [A]	△ C(TR Rail Length and Running Accuracy)					△ C(TR Rail Length and Running Accuracy)				
Running parallelism of Linear Guide Block surface [D] with respect to surface [B]	△ D(TR Rail Length and Running Accuracy)					△ D(TR Rail Length and Running Accuracy)				

## 2-11 Determining the Magnitude of a Preload

### What's Preload

Replacing larger rolling elements helps strengthen the entire rigidity of the carriage while there exists clearance with in ball circulation.

Increasing preload would decrease the vibration and reduce the corrosion caused by running back and forth. However, it would also add the workload within those rolling elements. The greater the preload, the greater the inner workload. Therefore, choosing preload has to consider the effect carefully between vibration and preload.

Table2.11.1 Grade of Preload

C : Dynamic load rating

Grade	Symbol	Preload force
Slight Clearance	ZF	0
No Preload	Z0	0
Light Preload	Z1	0.02C
Medium Preload	Z2	0.05C
Heavy Preload	Z3	0.07C

Table2.11.2 TR Series Radial Clearances

Unit :  $\mu\text{m}$

Preload Model No.	ZF	Z0	Z1	Z2	Z3
TR 15	5~12	-4~4	-12~-5	-20~-13	-28~-21
TR 20	6~14	-5~5	-14~-6	-23~-15	-32~-24
TR 25	7~16	-6~6	-16~-7	-26~-17	-36~-27
TR 30	8~18	-7~7	-18~-8	-29~-19	-40~-30
TR 35	9~20	-8~8	-20~-9	-32~-21	-44~-33
TR 45	10~22	-9~9	-22~-10	-35~-23	-48~-36
TR 55	11~24	-10~10	-24~-11	-38~-25	-52~-39
TR 65	12~26	-11~11	-26~-12	-41~-27	-56~-42

Table2.11.3 The difference between Interchangeability and Non-Interchangeability

Slight Clearance	Non-Interchangeable					Interchangeable	
	UP	SP	P	H	N	H	N
Preload			Z0	Z0	Z0	Z0	Z0
	Z1	Z1	Z1	Z1	Z1	Z1	Z1
	Z2	Z2	Z2	Z2	Z2		
	Z3	Z3	Z3	Z3			

## 2-12 Lubrication Method

### 2-12-1 Grease Nipples

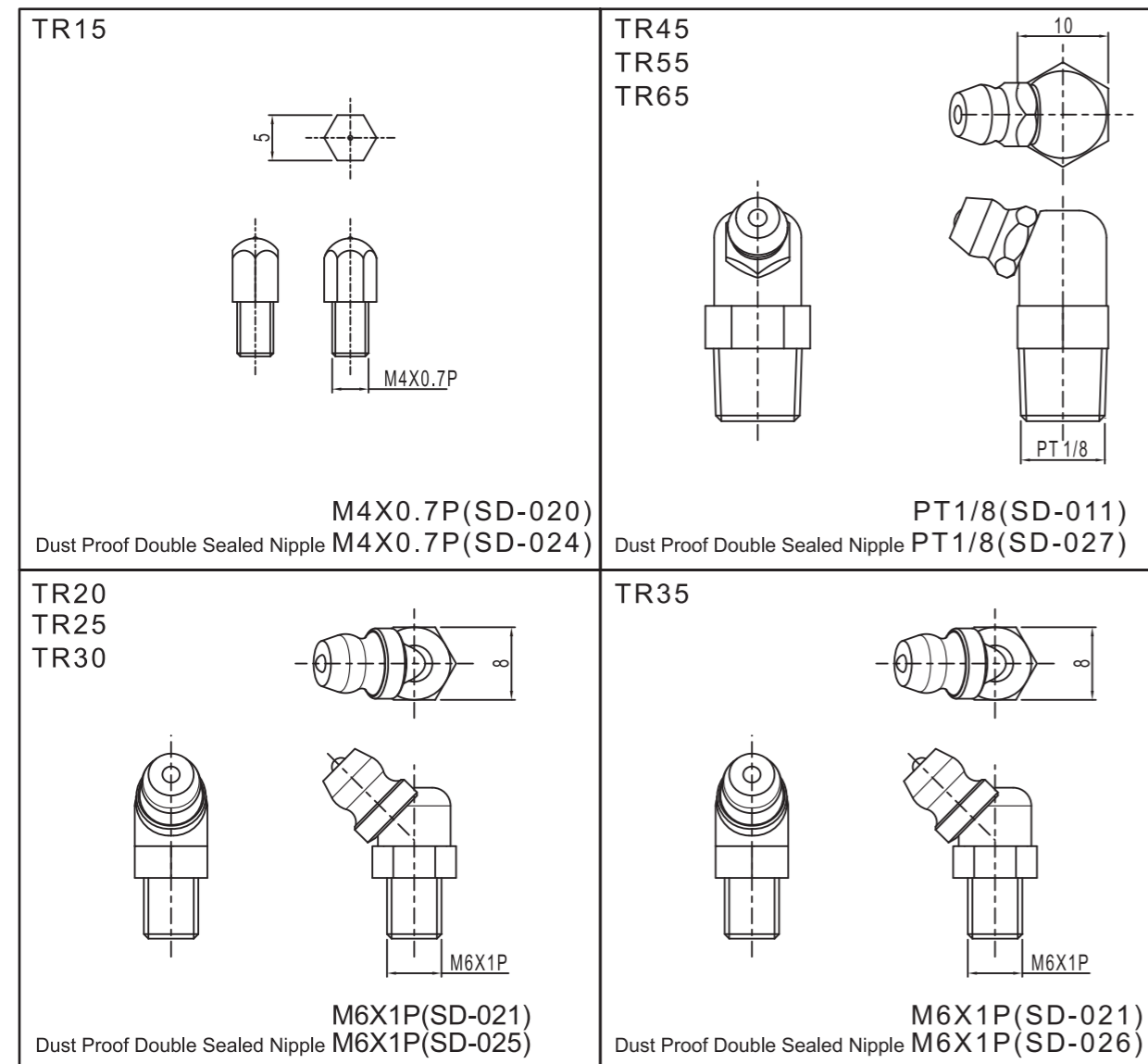

### 2-12-2 Type of Lubrication Coupler

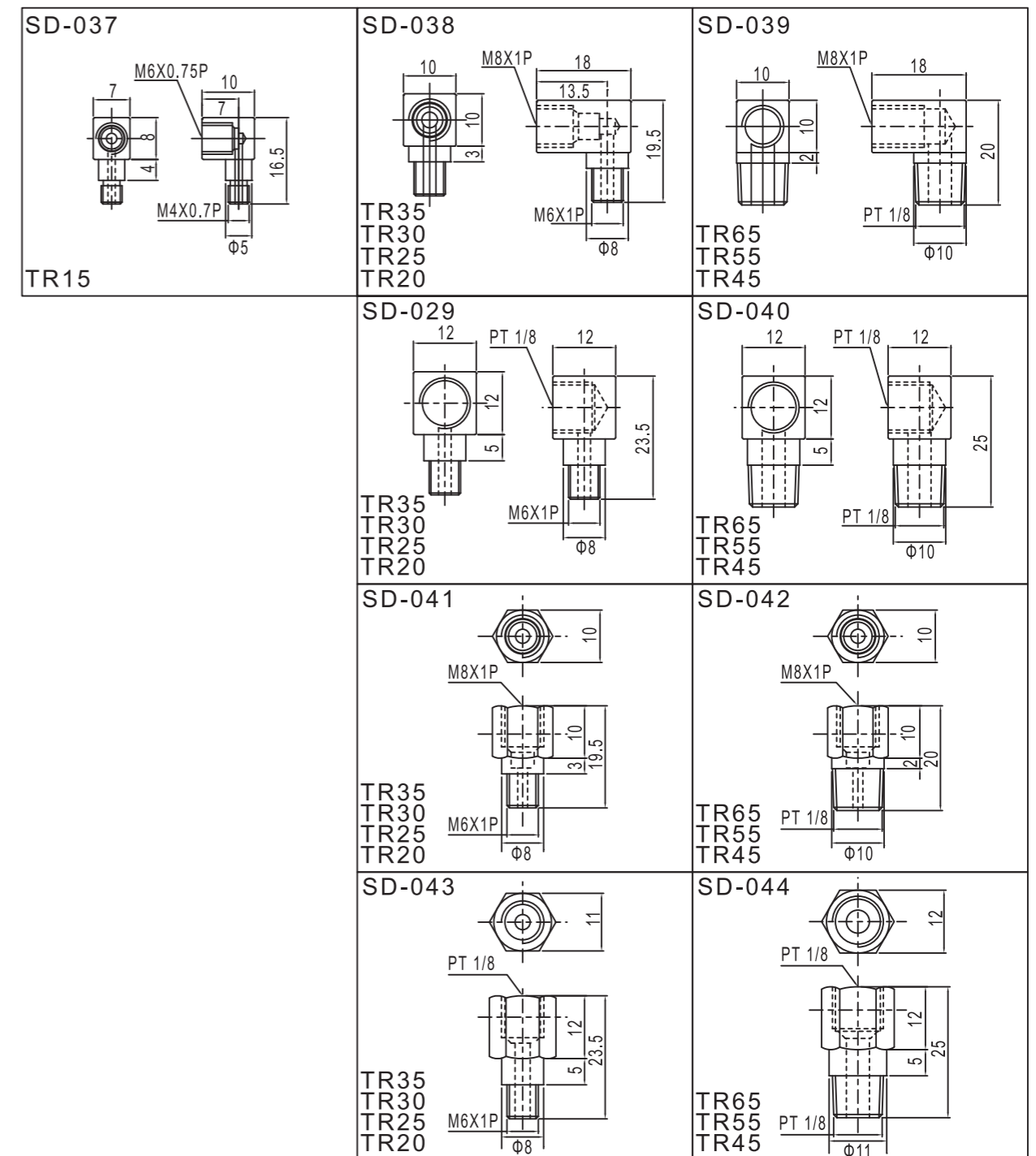



## 2-12-3 Mounting Location

The standard location of the grease fitting is at both ends of the block, but the nipple can be mounted at each side of block. For lateral installation, we recommend that the nipple be mounted at the non-reference side, otherwise please contact us. It is possible to perform lubrication by using the oil-piping joint.

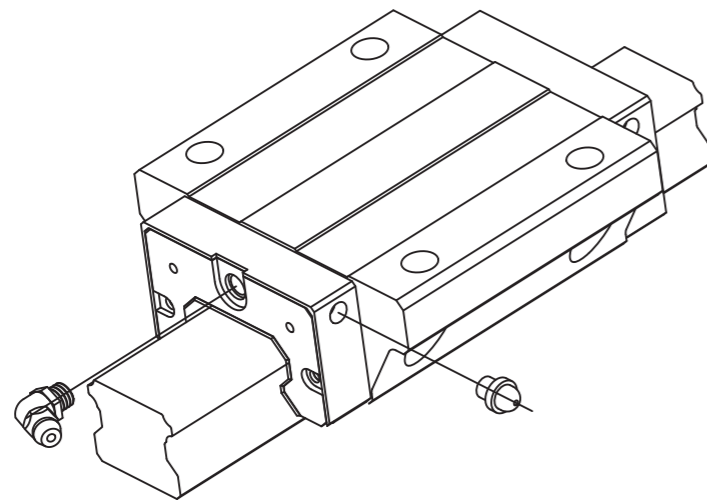

Mounting Location

Table2.12.1 The lubricant amount for a block filled with grease

Size	Grace(cm <sup>3</sup> )
TR15	1.3
TR20	2.5
TR25	2.5
TR30	7
TR35	9
TR45	15.2
TR55	40
TR65	75

Table2.12.2 Oil refilling rate

Size	Oil refilling rate (cm <sup>2</sup> /hr)
TR15	0.2
TR20	0.2
TR25	0.3
TR30	0.3
TR35	0.3
TR45	0.4
TR55	0.5
TR65	0.6

## 2-13 Dust-proof

### 2-13-1 Codes of accessories

If the following accessories are needed, please add the code followed by the model number.  
Special Option : Steel end seal, Steel end cap, Cover Strip ,contact TBI MOTION.

No symbol : Standard Protection (End Seal+ Bottom Seal)	U(End Seal+ Bottom Seal + Inner Seal)
	UZ(Double End Seal + Bottom Seal + Inner Seal)

Table2.13.1

Spacer	Thickness(mm)
TR15	4
TR20	4.5
TR25	4.5
TR30	4.5
TR35	5
TR45	6
TR55	6
TR65	8

### End seal and Bottom seal

To prevent life reduction caused by iron chips or dust entering the block.

### Inner Seal

efficiently avoid dust from the surface of rail or tapping hole getting inside the block.

### Double end seal

Enhances the wiping effect, foreign matter can be completely wiped off.

## 2-13-2 Dustproof Rails

Once the Linear Guide in the cutting machine is in operating, dust and foreign matter that enter the Linear Guide may cause abnormal wear and shorten the service life.

### Linear Guide rail mounting-hole cap :

Chips and foreign matter clogging the mounting holes of a Linear Guide rail may enter the Linear Guide block. To prevent from this situation, the mounting holes must be closed with dedicated caps, which must be installed to flush with the Linear Guide rail top surface. To insert a dedicated cap into a mounting hole, drive the cap in using a plastic hammer with a flat metal pad placed on the cap until it is flush with the Linear Guide rail top surface.

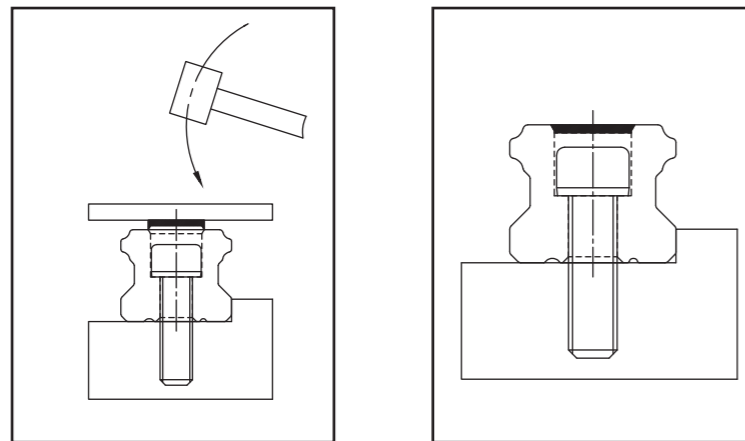

Fig2.10.2 Dustproof Rails

### Rail with tapped holes :

Fixing a rail with tapped hole is different from fixing a standard one. A major strength of it is the shape of the tapped hole; dust and chippings would not enter.

## 2-14 Friction

### Friction

The figure showed in the chart is the maxima friction.

Table2.11.1 End Cap friction rate Unit : kgf

Model No.	End Cap friction rate(Max)
TR15	0.25
TR20	0.35
TR25	0.4
TR30	0.5
TR35	0.7
TR45	1.3
TR55	1.6
TR65	2

## 2-15 Mounting-Surface Dimensional Tolerance

TR series Linear Guide has a Four-Way Equal-Load design, a slight dimensional error in the mounting surface can be absorbed by the natural self-adjusting capability of the product, thus ensuring smooth linear motion. In the table below are the dimensional tolerances for the mounting surface of TR Linear Guide.

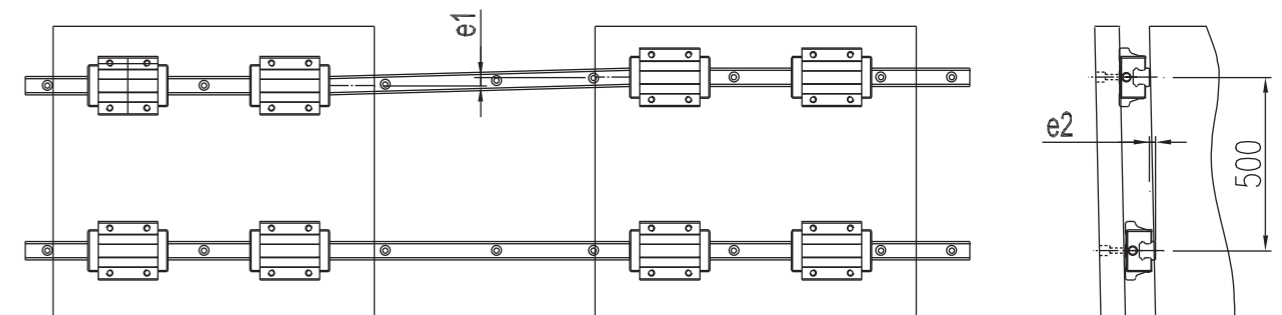

Fig2.15.1

Table2.15.1

Unit :  $\mu\text{m}$

Model No.	Tolerance for Parallelism Between Two Axes(e1)					Tolerance for Parallelism Between Two Axes(e2)				
	Z3	Z2	Z1	Z0	ZF	Z3	Z2	Z1	Z0	ZF
TR15			18	25	35			85	130	190
TR20		18	20	25	35		50	85	130	190
TR25	15	20	22	30	42	60	70	85	130	195
TR30	20	27	30	40	55	80	90	110	170	250
TR35	22	30	35	50	68	100	120	150	210	290
TR45	25	35	40	60	85	110	140	170	250	350
TR55	34	45	50	70	98	130	170	210	300	410
TR65	42	55	60	80	105	150	200	250	350	460





