

**Pulegge dentate per cinghie passo metrico**  
**Timing belt pulleys metric pitch**  
**Zahnriemenscheiben metrische teilung**  
**Poulies dentées pour courroies pas métrique**  
**Poleas dentadas para correas con**  
**paso en mm**



**Istruzioni per l'identificazione e la classificazione delle pulegge a passo metrico**  
**Instructions for the identification and classification of timing belt pulleys metric pitch**  
**Leitfaden zur suche und Klassifizierung der Zahnriemenscheiben metrische Teilung**  
**Instructions pour la recherche et la classification des poulies dentées pas métrique**  
**Guia a la busca y clasificación de las poleas dentadas en paso en mm**

**Esempio:**  
**ALTEZZA 40 T 10/32-2**  
 40 = Larghezza totale della puleggia 40 mm (L)  
 T 10 = Passo 10 mm  
 30 = N. denti  
 2 = N. della flangia

**Example:**  
**PULLEY 40 T 10/32-2**  
 40 = Total width of pulley 40 mm (L)  
 T 10 = Pitch 10 mm  
 30 = No. of teeth  
 2 = No. of flanges

**Beispiel:**  
**SCHIBE 40 T 10/32-2**  
 40 = Gesamtbreite der Scheibe 40 mm (L)  
 T 10 = Teilung 10 mm  
 30 = Zähnezahl  
 2 = Anzahl der Bordscheiben

**Exemple:**  
**POULIE 40 T 10/32-2**  
 40 = Largeur totale de la poulie 40 mm (L)  
 T 10 = Pas 10 mm  
 30 = N. de dents  
 2 = N. de flasques

**Ejemplo:**  
**POLEA 40 T 10/32-2**  
 40 = Ancho total de la polea 40 mm (L)  
 T 10 = Paso 10 mm  
 30 = Cantidad de dientes  
 2 = Cantidad de tapetas

**Materiale:**  
**alluminio 6082 T6**  
**UNI 9006/4 adatto al trattamento anodico**

**Material:**  
**aluminium 6082 T6**  
**UNI 9006/4 suitable for anodic treatment**

**Material:**  
**aluminium 6082 T6**  
**UNI 9006/4 geeignet für anodischen oxydation**

**Material:**  
**aluminium 6082 T6**  
**UNI 9006/4 apte au traitement anodique**

**Material:**  
**aluminio 6082 T6**  
**UNI 9006/4 apto para la oxidación anodica**

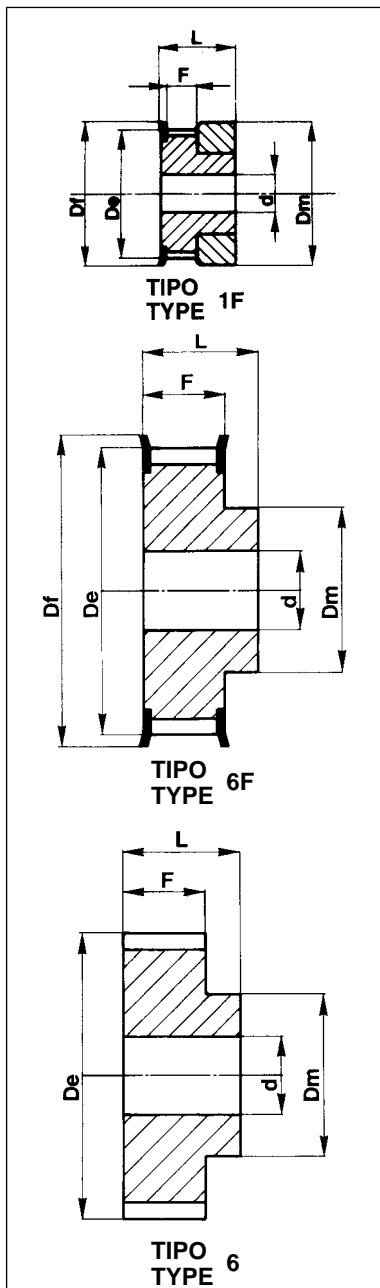

**Pulegge dentate per cinghie passo metrico**  
**Timing belt pulleys metric pitch**  
**Zahnriemenscheiben metrische teilung**  
**Poulies dentées pour courroies pas métrique**  
**Poleas dentadas para correas con paso en mm**

**T 2,5**

(PASSO 2,5 mm) PER CINGHIA LARGHEZZA 6 mm  
 (PITCH 2,5 mm) FOR BELT WIDTH 6 mm  
 (TEILUNG 2,5 mm) FUER RIEMENBREITE 6 mm  
 (PAS 2,5 mm) POUR COURROIES LARGEUR 6 mm  
 (PASO 2,5 mm) PARA CORREAS ANCHO 6 mm

CODICE CODE SYMBOL FABRIKNUMMER CODE SYMBOLE NUMERO DE FABRICA	NOSTRO CODICE OUR CODE UNSER KODE NOTRE CODE NUESTRO CODIGO	TIPO TYPE TYP TIPO TIPO	TIPO FLANGIA FLANGES TYPE BORDSCHEIBEN TYP TIPO FLASQUES TIPO TAPETAS	N.DENTI N. OF TEETH ZAHNEZAHL N. BRE DE DENTS CANTIDAD DE DIENTES	Dp	De	Df	Dm	F	L	d	PESO WEIGHT POIDS PESO Kg
16T2,5/12-2	16T2012	1F	F01	12	9,60	9,00	13,0	13	9	16	4	0,004
16T2,5/14-2	16T2014	1F	F02	14	11,20	10,60	15,0	15	9	16	4	0,006
16T2,5/15-2	16T2015	1F	F02	15	12,00	11,40	15,0	15	9	16	4	0,006
16T2,5/16-2	16T2016	1F	F03	16	12,80	12,20	16,0	16	9	16	4	0,006
16T2,5/18-2	16T2018	6F	F04	18	14,40	13,80	17,5	10	10	16	4	0,006
16T2,5/19-2	16T2019	6F	F05	19	15,20	14,60	18,0	10	10	16	4	0,007
16T2,5/20-2	16T2020	6F	F06	20	16,00	15,40	20,0	11	10	16	4	0,008
16T2,5/22-2	16T2022	6F	F07	22	16,60	17,00	23,0	11	10	16	4	0,010
16T2,5/24-2	16T2024	6F	F07	24	19,15	18,55	23,0	12	10	16	4	0,012
16T2,5/25-2	16T2025	6F	F07	25	19,95	19,35	23,0	13	10	16	4	0,013
16T2,5/26-2	16T2026	6F	F09	26	20,75	20,15	25,0	14	10	16	4	0,015
16T2,5/28-2	16T2028	6F	F09	28	22,35	21,75	25,0	14	10	16	4	0,016
16T2,5/30-2	16T2030	6F	F09	30	23,95	23,35	28,0	16	10	16	6	0,018
16T2,5/32-2	16T2032	6F	F10	32	25,95	24,95	32,0	16	10	16	6	0,020
16T2,5/36-2	16T2036	6F	F12	36	28,75	28,10	36,0	20	10	16	6	0,026
16T2,5/40-2	16T2040	6F	F14	40	31,90	31,30	38,0	22	10	16	6	0,032
16T2,5/44-0	16T2044	6F	F15	44	35,10	34,50	42,0	24	10	16	6	0,038
16T2,5/48-0	16T2048	6	—	48	38,30	37,70	—	26	10	16	6	0,048
16T2,5/60-0	16T2060	6	—	60	47,85	47,25	—	34	10	16	8	0,073

PER PULEGGE AVENTI UN NUMERO DI DENTI DIVERSO DALLA TABELLA, CONSULTATECI.  
 FOR PULLEYS WITH A NUMBER OF TEETH NOT INCLUDED IN THESE TABLES PLEASE ASK FOR OUR QUOTATION.  
 VERLAGEN SIE ANGEBOUOT FUER ZAHNSCHEIBEN MIT ANZHAL VON ZAEHNEN DIE NICHT IN DIESEN TAFELN AUFGEFUEHRT SIND.  
 POUR LES POULIES AVEC UN NOMBRE DE DENTS DIFFERENT DU TABLEAU, NOUS CONSULTER.  
 PIDAN OFERTA POR LO QUE CONCIERNE UNA CANTIDAD DE DIENTES NO INCLUIDA EN ESTAS TABLAS.

**Pulegge dentate per cinghie passo metrico**  
**Timing belt pulleys metric pitch**  
**Zahnriemenscheiben metrische Teilung**  
**Poulies dentées pour courroies pas métrique**  
**Poleas dentadas para correas con paso en mm**

**Materiale: alluminio 6082 T6 UNI 9006/4 adatto al trattamento anodico**

**Material: aluminium 6082 T6 UNI 9006/4 suitable for anodic treatment**

**Material: aluminium 6082 T6 UNI 9006/4 geeignet für anodischen oxydation**

**Material: aluminium 6082 T6 UNI 9006/4 apte au traitement anodique**

**Material: aluminio 6082 T6 UNI 9006/4 apto para la oxidacion anodica**

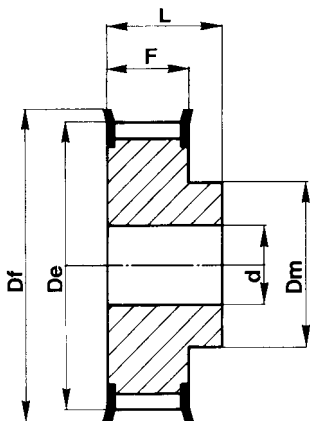

**TIPO TYPE 6F**

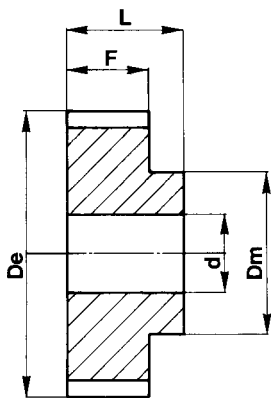

**TIPO TYPE 6**

(PASSO 5 mm) PER CINGHIA LARGHEZZA 10 mm  
(PITCH 5 mm) FOR BELT WIDTH 10 mm  
(Teilung 5 mm) fuer RIEMENBREITE 10 mm  
(PAS 5 mm) POUR COURROIS LARGEUR 10 mm  
(PASO 5 mm) PARA CORREAS ANCHO 10 mm

**T 5**

CODICE CODE SYMBOL FABRIKNUMMER CODE SYMBOLE NUMERO DE FABRICA	NOSTRO CODICE OUR CODE UNSER KODE NOTRE CODE NUESTRO CODIGO	TIPO TYPE TYP TYPE TIPO	TIPO FLANGIA FLANGES TYPE BORDSCHEIBEN TYP TYPE FLASQUES TIPO TAPETAS	N.DENTI N. OF TEETH ZAHNEZAHL N. BRE DE DENTS CANTIDAD DE DIENTES	Dp	De	Df	Dm	F	L	d	PESO WEIGHT GEWICHT POIDS PESO Kg
21T5/10-2	21T5010	6F	F06	10	16,05	15,05	20,0	8	15	21	4	0,012
21T5/12-2	21T5012	6F	F07	12	19,25	18,25	23,0	11	15	21	4	0,016
21T5/14-2	21T5014	6F	F08	14	22,45	21,45	25,0	13	15	21	4	0,019
21T5/15-2	21T5015	6F	F09	15	24,05	23,05	28,0	16	15	21	6	0,021
21T5/16-2	21T5016	6F	F10	16	25,06	24,60	32,0	18	15	21	6	0,025
21T5/18-2	21T5018	6F	F10	18	28,80	27,80	32,0	20	15	21	6	0,031
21T5/19-2	21T5019	6F	F12	19	30,40	29,40	36,0	22	15	21	6	0,036
21T5/20-2	21T5020	6F	F12	20	32,00	31,00	36,0	23	15	21	6	0,038
21T5/22-2	21T5022	6F	F14	22	35,15	34,15	38,0	24	15	21	6	0,054
21T5/24-2	21T5024	6F	F15	24	38,40	37,40	42,0	26	15	21	6	0,056
21T5/25-2	21T5025	6F	F17	25	39,95	38,95	44,0	26	15	21	6	0,058
21T5/26-2	21T5026	6F	F17	26	41,60	40,60	44,0	26	15	21	6	0,064
21T5/27-2	21T5027	6F	F18	27	43,20	42,20	48,0	30	15	21	8	0,070
21T5/28-2	21T5028	6F	F18	28	44,75	43,75	48,0	32	15	21	8	0,075
21T5/30-2	21T5030	6F	F19	30	47,95	46,95	51,0	34	15	21	8	0,081
21T5/32-2	21T5032	6F	F20	32	51,10	50,10	54,0	38	15	21	8	0,088
21T5/36-2	21T5036	6F	F24	36	57,45	56,45	64,0	38	15	21	8	0,114
21T5/40-2	21T5040	6F	F25	40	63,85	62,85	66,0	40	15	21	8	0,138
21T5/42-2	21T5042	6F	F26	42	67,00	66,00	70,0	40	15	21	8	0,165
21T5/44-0	21T5044	6	—	44	70,20	69,20	—	45	15	21	8	0,200
21T5/48-0	21T5048	6	—	48	76,55	75,55	—	50	15	21	8	0,307
21T5/60-0	21T5060	6	—	60	95,65	94,65	—	65	15	21	8	0,180

(PASSO 5 mm) PER CINGHIA LARGHEZZA 16 mm  
(PITCH 5 mm) FOR BELT WIDTH 16 mm  
(Teilung 5 mm) fuer RIEMENBREITE 16 mm  
(PAS 5 mm) POUR COURROIS LARGEUR 16 mm  
(PASO 5 mm) PARA CORREAS ANCHO 16 mm

**T 5**

CODICE CODE SYMBOL FABRIKNUMMER CODE SYMBOLE NUMERO DE FABRICA	NOSTRO CODICE OUR CODE UNSER KODE NOTRE CODE NUESTRO CODIGO	TIPO TYPE TYP TYPE TIPO	TIPO FLANGIA FLANGES TYPE BORDSCHEIBEN TYP TYPE FLASQUES TIPO TAPETAS	N.DENTI N. OF TEETH ZAHNEZAHL N. BRE DE DENTS CANTIDAD DE DIENTES	Dp	De	Df	Dm	F	L	d	PESO WEIGHT GEWICHT POIDS PESO Kg
27T5/10-2	27T5010	6F	F06	10	16,05	15,05	20,0	8	21	27	4	0,016
27T5/12-2	27T5012	6F	F07	12	19,25	18,25	23,0	11	21	27	4	0,022
27T5/14-2	27T5014	6F	F08	14	22,45	21,45	25,0	13	21	27	4	0,026
27T5/15-2	27T5015	6F	F09	15	24,05	23,05	28,0	16	21	27	6	0,029
27T5/16-2	27T5016	6F	F10	16	25,06	24,60	32,0	18	21	27	6	0,035
27T5/18-2	27T5018	6F	F10	18	28,80	27,80	32,0	20	21	27	6	0,043
27T5/19-2	27T5019	6F	F12	19	30,40	29,40	36,0	22	21	27	6	0,049
27T5/20-2	27T5020	6F	F12	20	32,00	31,00	36,0	23	21	27	6	0,053
27T5/22-2	27T5022	6F	F14	22	35,15	34,15	38,0	24	21	27	6	0,062
27T5/24-2	27T5024	6F	F15	24	38,40	37,40	42,0	26	21	27	6	0,076
27T5/25-2	27T5025	6F	F17	25	39,95	38,95	44,0	26	21	27	6	0,081
27T5/26-2	27T5026	6F	F17	26	41,60	40,60	44,0	26	21	27	6	0,085
27T5/27-2	27T5027	6F	F18	27	43,20	42,20	48,0	30	21	27	8	0,090
27T5/28-2	27T5028	6F	F18	28	44,75	43,75	48,0	32	21	27	8	0,095
27T5/30-2	27T5030	6F	F19	30	47,95	46,95	51,0	34	21	27	8	0,105
27T5/32-2	27T5032	6F	F20	32	51,10	50,10	54,0	38	21	27	8	0,123
27T5/36-2	27T5036	6F	F24	36	57,45	56,45	64,0	38	21	27	8	0,160
27T5/40-2	27T5040	6F	F25	40	63,85	62,85	66,0	40	21	27	8	0,193
27T5/42-2	27T5042	6F	F26	42	67,00	66,00	70,0	40	21	27	8	0,245
27T5/44-0	27T5044	6	—	44	70,20	69,20	—	45	21	27	8	0,280
27T5/48-0	27T5048	6	—	48	76,55	75,55	—	50	21	27	8	0,430
27T5/60-0	27T5060	6	—	60	95,65	94,65	—	65	21	27	8	0,108

(PASSO 5 mm) PER CINGHIA LARGHEZZA 25 mm  
(PITCH 5 mm) FOR BELT WIDTH 25 mm  
(Teilung 5 mm) fuer RIEMENBREITE 25 mm  
(PAS 5 mm) POUR COURROIS LARGEUR 25 mm  
(PASO 5 mm) PARA CORREAS ANCHO 25 mm

**T 5**

CODICE CODE SYMBOL FABRIKNUMMER CODE SYMBOLE NUMERO DE FABRICA	NOSTRO CODICE OUR CODE UNSER KODE NOTRE CODE NUESTRO CODIGO	TIPO TYPE TYP TYPE TIPO	TIPO FLANGIA FLANGES TYPE BORDSCHEIBEN TYP TYPE FLASQUES TIPO TAPETAS	N.DENTI N. OF TEETH ZAHNEZAHL N. BRE DE DENTS CANTIDAD DE DIENTES	Dp	De	Df	Dm	F	L	d	PESO WEIGHT GEWICHT POIDS PESO Kg
36T5/10-2	36T5010	6F	F06	10	16,05	15,05	20,0	8	30	36	4	0,023
36T5/12-2	36T5012	6F	F07	12	19,25	18,25	23,0	11	30	36	4	0,031
36T5/14-2	36T5014	6F	F08	14	22,45	21,45	25,0	13	30	36	4	0,037
36T5/15-2	36T5015	6F	F09	15	24,05	23,05	28,0	16	30	36	6	0,041
36T5/16-2	36T5016	6F	F10	16	25,06	24,60	32,0	18	30	36	6	0,050
36T5/18-2	36T5018	6F	F10	18	28,80	27,80	32,0	20	30	36	6	0,061
36T5/19-2	36T5019	6F	F12	19	30,40	29,40	36,0	22	30	36	6	0,070
36T5/20-2	36T5020	6F	F12	20	32,00	31,00	36,0	23	30	36	6	0,076
36T5/22-2	36T5022	6F	F14	22	35,15	34,15	38,0	24	30	36	6	0,092
36T5/24-2	36T5024	6F	F15	24	38,40	37,40	42,0	26	30	36	8	0,109
36T5/25-2	36T5025	6F	F17	25	39,95	38,95	44,0	26	30	36	8	0,116
36T5/26-2	36T5026	6F	F17	26	41,60	40,60	44,0	26	30	36	8	0,121
36T5/27-2	36T5027	6F	F18	27	43,20	42,20	48,0	30	30	36	8	0,128
36T5/28-2	36T5028	6F	F18	28	44,75	43,75	48,0	32	30	36	8	0,142
36T5/30-2	36T5030	6F	F19	30	47,95	46,95	51,0	34	30	36	8	0,150
36T5/32-2	36T5032	6F	F20	32	51,10	50,10	54,0	38	30	36	8	0,176
36T5/36-2	36T5036	6F	F24	36	57,45	56,45	64,0	38	30	36	8	0,230
36T5/40-2	36T5040	6F	F25	40	63,85	62,85	66,0	40	30	36	8	0,276
36T5/42-2	36T5042	6F	F26	42	67,00	66,00	70,0	40	30	36	8	0,352
36T5/44-0	36T5044	6	—	44	70,20	69,20	—	45	30	36	8	0,400
36T5/48-0	36T5048	6	—	48	76,55	75,55	—	50	30	36	8	0,614
36T5/60-0	36T5060	6	—	60	95,65	94,65	—	65	30	36	8	0,180

**Pulegge dentate per cinghie passo metrico**  
**Timing belt pulleys metric pitch**  
**Zahnriemenscheiben metrische Teilung**  
**Poulies dentées pour courroies pas métrique**  
**Poleas dentadas para correas con paso en mm**

**Materiale: alluminio 6082 T6 UNI 9006/4 adatto al trattamento anodico**

**Material: aluminium 6082 T6 UNI 9006/4 suitable for anodic treatment**

**Material: aluminium 6082 T6 UNI 9006/4 geeignet für anodischen oxydation**

**Material: aluminium 6082 T6 UNI 9006/4 apte au traitement anodique**

**Material: aluminio 6082 T6 UNI 9006/4 apto para la oxidacion anodica**

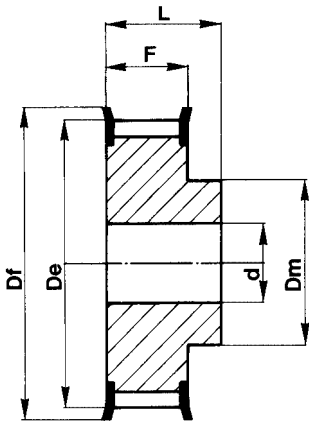

**TIPO 6F**  
**TYPE 6F**

(PASSO 10 mm) PER CINGHIA LARGHEZZA 16 mm  
(PITCH 10 mm) FOR BELT WIDTH 16 mm  
(Teilung 10 mm) fuer Riemenbreite 16 mm  
(PAS 10 mm) POUR COURROIES LARGEUR 16 mm  
(PASO 10 mm) PARA CORREAS ANCHO 16 mm

**T 10**

CODICE CODE SYMBOL FABRIKNUMMER CODE SYMBOLE NUMERO DE FABRICA	NOSTRO CODICE OUR CODE UNSER KODE NOTRE CODE NUESTRO CODIGO	TIPO TYPE TYP TYPE TIPO	TIPO FLANGIA FLANGES TYPE BORDSCHEIBEN TYP TYPE FLASQUES TIPO TAPETAS	N.DENTI N. OF TEETH ZAHNEZAHL N. BRE DE DENTS CANTIDAD DE DIENTES	Dp	De	Df	Dm	F	L	d	PESO WEIGHT GEWICHT POIDS PESO Kg
31T10/12-2	31T1012	6F	F15	12	38,35	36,35	42	28	21	31	6	0,076
31T10/14-2	31T1014	6F	F18	14	44,70	42,70	48	32	21	31	8	0,104
31T10/15-2	31T1015	6F	F19	15	47,90	45,90	51	32	21	31	8	0,116
31T10/16-2	31T1016	6F	F20	16	51,10	49,10	54	35	21	31	8	0,134
31T10/18-2	31T1018	6F	F22	18	57,45	55,45	60	40	21	31	8	0,167
31T10/19-2	31T1019	6F	F25	19	60,65	58,65	66	44	21	31	8	0,184
31T10/20-2	31T1020	6F	F25	20	63,80	61,80	66	46	21	31	8	0,208
31T10/22-2	31T1022	6F	F27	22	70,20	68,20	75	52	21	31	8	0,240
31T10/24-2	31T1024	6F	F29	24	76,55	74,55	83	58	21	31	8	0,288
31T10/25-2	31T1025	6F	F29	25	79,75	77,75	83	60	21	31	8	0,295
31T10/26-2	31T1026	6F	F30	26	82,90	80,90	87	60	21	31	8	0,310
31T10/27-2	31T1027	6F	F31	27	86,10	84,10	91	60	21	31	8	0,364
31T10/28-2	31T1028	6F	F32	28	89,25	87,25	93	60	21	31	8	0,441
31T10/30-2	31T1030	6F	F33	30	95,65	93,65	97	60	21	31	8	0,493
31T10/32-2	31T1032	6F	F35	32	102,00	100,00	106	65	21	31	10	0,623
31T10/36-2	31T1036	6F	F38	36	114,75	112,75	120	70	21	31	10	0,767
31T10/40-2	31T1040	6F	F41	40	127,45	125,45	131	80	21	31	10	0,950
31T10/44-0	31T1044	6	—	44	140,20	138,20	—	88	21	31	10	1,090
31T10/48-0	31T1048	6	—	48	152,95	150,95	—	95	21	31	16	1,704
31T10/60-0	31T1060	6	—	60	191,15	189,10	—	110	21	31	16	1,704

(PASSO 10 mm) PER CINGHIA LARGHEZZA 25 mm  
(PITCH 10 mm) FOR BELT WIDTH 25 mm  
(Teilung 10 mm) fuer Riemenbreite 25 mm  
(PAS 10 mm) POUR COURROIES LARGEUR 25 mm  
(PASO 10 mm) PARA CORREAS ANCHO 25 mm

**T 10**

CODICE CODE SYMBOL FABRIKNUMMER CODE SYMBOLE NUMERO DE FABRICA	NOSTRO CODICE OUR CODE UNSER KODE NOTRE CODE NUESTRO CODIGO	TIPO TYPE TYP TYPE TIPO	TIPO FLANGIA FLANGES TYPE BORDSCHEIBEN TYP TYPE FLASQUES TIPO TAPETAS	N.DENTI N. OF TEETH ZAHNEZAHL N. BRE DE DENTS CANTIDAD DE DIENTES	Dp	De	Df	Dm	F	L	d	PESO WEIGHT GEWICHT POIDS PESO Kg
40T10/12-2	40T1012	6F	F15	12	38,35	36,35	42	28	30	40	6	0,099
40T10/14-2	40T1014	6F	F18	14	44,70	42,70	48	32	30	40	8	0,134
40T10/15-2	40T1015	6F	F19	15	47,90	45,90	51	32	30	40	8	0,152
40T10/16-2	40T1016	6F	F20	16	51,10	49,10	54	35	30	40	8	0,176
40T10/18-2	40T1018	6F	F22	18	57,45	55,45	60	40	30	40	8	0,224
40T10/19-2	40T1019	6F	F25	19	60,65	58,65	66	44	30	40	8	0,247
40T10/20-2	40T1020	6F	F25	20	63,80	61,80	66	46	30	40	8	0,276
40T10/22-2	40T1022	6F	F27	22	70,20	68,20	75	52	30	40	8	0,310
40T10/24-2	40T1024	6F	F29	24	76,55	74,55	83	58	30	40	8	0,392
40T10/25-2	40T1025	6F	F29	25	79,75	77,75	83	60	30	40	8	0,422
40T10/26-2	40T1026	6F	F30	26	82,90	80,90	87	60	30	40	8	0,480
40T10/27-2	40T1027	6F	F31	27	86,10	84,10	91	60	30	40	8	0,536
40T10/28-2	40T1028	6F	F32	28	89,25	87,25	93	60	30	40	8	0,590
40T10/30-2	40T1030	6F	F33	30	95,65	93,65	97	60	30	40	8	0,640
40T10/32-2	40T1032	6F	F35	32	102,00	100,00	106	65	30	40	10	0,693
40T10/36-2	40T1036	6F	F38	36	114,75	112,75	120	70	30	40	10	0,873
40T10/40-2	40T1040	6F	F41	40	127,45	125,45	131	80	30	40	10	1,067
40T10/44-0	40T1044	6	—	44	140,20	138,20	—	88	30	40	10	1,310
40T10/48-0	40T1048	6	—	48	152,95	150,95	—	95	30	40	16	1,516
40T10/60-0	40T1060	6	—	60	191,15	189,10	—	110	30	40	16	2,339

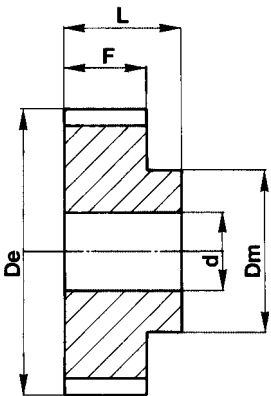

**TIPO 6**  
**TYPE 6**

**Pulegge dentate per cinghie passo metrico**  
**Timing belt pulleys metric pitch**  
**Zahnriemenscheiben metrische Teilung**  
**Poulies dentées pour courroies pas métrique**  
**Poleas dentadas para correas con paso en mm**

**Materiale: alluminio 6082 T6 UNI 9006/4 adatto al trattamento anodico**

**Material: aluminium 6082 T6 UNI 9006/4 suitable for anodic treatment**

**Material: aluminium 6082 T6 UNI 9006/4 geeignet für anodischen oxydation**

**Material: aluminium 6082 T6 UNI 9006/4 apte au traitement anodique**

**Material: aluminio 6082 T6 UNI 9006/4 apto para la oxidacion anodica**

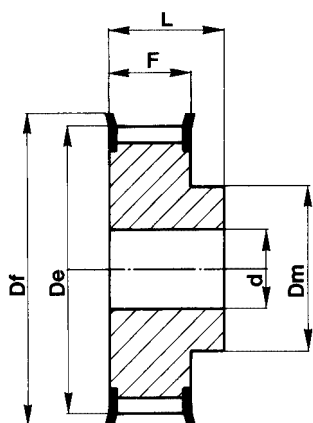

**TIPO 6F**  
**TYPE 6F**

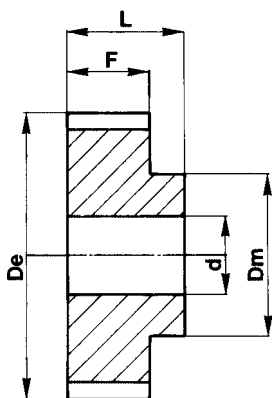

**TIPO 6**  
**TYPE 6**

(PASSO 10 mm) PER CINGHIA LARGHEZZA 32 mm  
(PITCH 10 mm) FOR BELT WIDTH 32 mm  
(Teilung 10 mm) FUER RIEMENBREITE 32 mm  
(PAS 10 mm) POUR COURROIES LARGEUR 32 mm  
(PASO 10 mm) PARA CORREAS ANCHO 32 mm

**T 10**

CODICE CODE SYMBOL FABRIKNUMMER CODE SYMBOLE NUMERO DE FABRICA	NOSTRO CODICE OUR CODE UNSER KODE NOTRE CODE NUESTRO CODIGO	TIPO TYPE TYP TYPE TIPO	TIPO FLANGIA FLANGES TYPE BORDSCHEIBEN TYP TYPE FLASQUES TIPO TAPETAS	N.DENTI N. OF TEETH ZAHNEZAHL N. BRE DE DENTS CANTIDAD DE DIENTES	Dp	De	Df	Dm	F	L	d	PESO WEIGHT GEWICHT POIDS PESO Kg
47T10/18-2	47T1018	6F	F22	18	57,45	55,45	60	40	37	47	10	0,253
47T10/19-2	47T1019	6F	F25	19	60,65	58,65	66	44	37	47	10	0,286
47T10/20-2	47T1020	6F	F25	20	63,80	61,80	66	46	37	47	12	0,322
47T10/22-2	47T1022	6F	F27	22	70,20	68,20	75	52	37	47	12	0,393
47T10/24-2	47T1024	6F	F29	24	76,55	74,55	83	58	37	47	12	0,475
47T10/25-2	47T1025	6F	F29	25	79,75	77,70	83	60	37	47	12	0,527
47T10/26-2	47T1026	6F	F30	26	82,90	80,90	87	60	37	47	12	0,564
47T10/27-2	47T1027	6F	F31	27	86,10	84,10	91	60	37	47	12	0,602
47T10/28-2	47T1028	6F	F32	28	89,25	87,25	93	60	37	47	12	0,642
47T10/30-2	47T1030	6F	F33	30	95,65	93,65	97	60	37	47	12	0,740
47T10/32-2	47T1032	6F	F35	32	102,00	100,00	106	65	37	47	12	0,844
47T10/36-2	47T1036	6F	F38	36	114,75	112,45	120	70	37	47	16	1,063
47T10/40-2	47T1040	6F	F41	40	127,45	125,45	131	80	37	47	16	1,371
47T10/44-0	47T1044	6	—	44	140,20	138,20	—	88	37	47	16	1,611
47T10/48-0	47T1048	6	—	48	152,95	150,95	—	95	37	47	16	1,913
47T10/60-0	47T1060	6	—	60	191,10	189,10	—	110	37	47	16	3,004

(PASSO 10 mm) PER CINGHIA LARGHEZZA 50 mm  
(PITCH 10 mm) FOR BELT WIDTH 50 mm  
(Teilung 10 mm) FUER RIEMENBREITE 50 mm  
(PAS 10 mm) POUR COURROIES LARGEUR 50 mm  
(PASO 10 mm) PARA CORREAS ANCHO 50 mm

**T 10**

CODICE CODE SYMBOL FABRIKNUMMER CODE SYMBOLE NUMERO DE FABRICA	NOSTRO CODICE OUR CODE UNSER KODE NOTRE CODE NUESTRO CODIGO	TIPO TYPE TYP TYPE TIPO	TIPO FLANGIA FLANGES TYPE BORDSCHEIBEN TYP TYPE FLASQUES TIPO TAPETAS	N.DENTI N. OF TEETH ZAHNEZAHL N. BRE DE DENTS CANTIDAD DE DIENTES	Dp	De	Df	Dm	F	L	d	PESO WEIGHT GEWICHT POIDS PESO Kg
66T10/18-2	66T1018	6F	F22	18	57,45	55,45	60	40	56	66	10	0,422
66T10/19-2	66T1019	6F	F25	19	60,65	58,65	66	44	56	66	10	0,466
66T10/20-2	66T1020	6F	F25	20	63,80	61,80	66	46	56	66	12	0,520
66T10/22-2	66T1022	6F	F27	22	70,20	68,20	75	52	56	66	12	0,640
66T10/24-2	66T1024	6F	F29	24	76,55	74,55	83	58	56	66	12	0,736
66T10/25-2	66T1025	6F	F29	25	79,75	77,70	83	60	56	66	12	0,766
66T10/26-2	66T1026	6F	F30	26	82,90	80,90	87	60	56	66	12	0,845
66T10/27-2	66T1027	6F	F31	27	86,10	84,10	91	60	56	66	12	0,946
66T10/28-2	66T1028	6F	F32	28	89,25	87,25	93	60	56	66	12	0,110
66T10/30-2	66T1030	6F	F33	30	95,65	93,65	97	60	56	66	12	1,169
66T10/32-2	66T1032	6F	F35	32	102,00	100,00	106	65	56	66	12	1,300
66T10/36-2	66T1036	6F	F38	36	114,75	112,75	120	70	56	66	16	1,637
66T10/40-2	66T1040	6F	F41	40	127,45	125,45	131	80	56	66	16	1,999
66T10/44-0	66T1044	6	—	44	140,20	138,20	—	88	56	66	16	2,420
66T10/48-0	66T1048	6	—	48	152,95	150,95	—	95	56	66	16	2,830
66T10/60-0	66T1060	6	—	60	191,10	189,10	—	110	56	66	16	4,366

**Pulegge dentate per cinghie passo metrico**  
**Timing belt pulleys metric pitch**  
**Zahnriemenscheiben metrische Teilung**  
**Poulies dentées pour courroies pas métrique**  
**Poleas dentadas para correas con paso en mm**

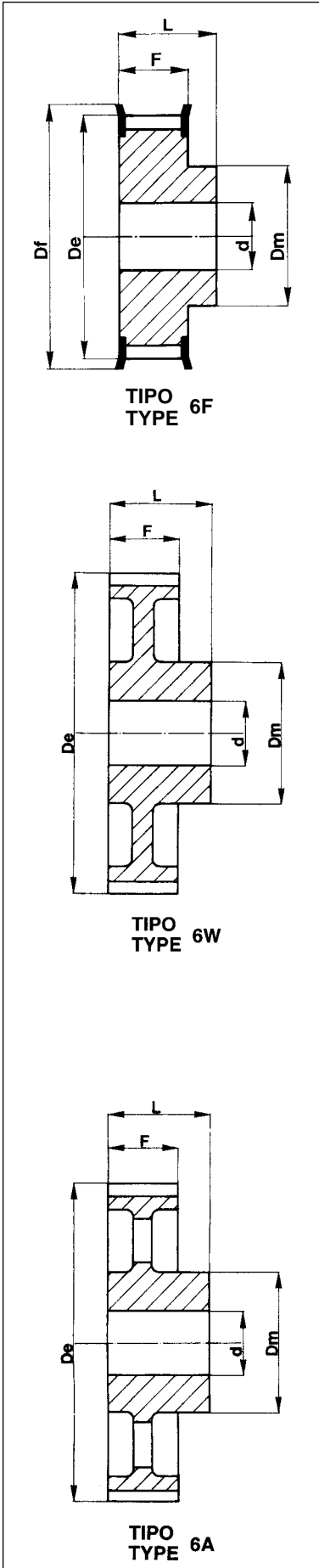

(PASSO 20 mm) PER CINGHIA LARGHEZZA 32 mm  
(PITCH 20 mm) FOR BELT WIDTH 32 mm  
(Teilung 20 mm) fuer RIEMENBREITE 32 mm  
(PAS 20 mm) POUR COURROIES LARGEUR 32 mm  
(PASO 20 mm) PARA CORREAS ANCHO 32 mm

### T 20

	CODICE CODE SYMBOL FABRIKNUMMER CODE SYMBOLE NUMERO DE FABRICA	NOSTRO CODICE OUR CODE UNSER KODE NOTRE CODE NUESTRO CODIGO	TIPO TYPE TYP TYPE TIPO	TIPO FLANGIA FLANGES TYPE BORDSCHEIBEN TYP TYPE FLASQUES TIPO TAPETAS	N.DENTI N. OF TEETH ZAHNEZAHL N. BRE DE DENTS CANTIDAD DE DIENTES	De	Df	Dm	F	L	d	PESO WEIGHT GEWICHT POIDS PESO Kg
GHISA - CAST IRON - GUESSEISEN FONTE - FUNDICION	53T20/18-2	53T2018	6F	F38	18	111,75	120	80	38	53	15	
	53T20/20-2	53T2020	6F	F43	20	124,50	138	90	38	53	15	
	53T20/22-2	53T2022	6F	F46	22	137,20	146	90	38	53	15	
	53T20/24-2	53T2024	6F	F50	24	149,95	158	95	38	53	15	
	53T20/25-2	53T2025	6F	F52	25	156,30	168	95	38	53	15	
	53T20/30-2	53T2030	6F	F59	30	188,15	200	110	38	53	15	
	53T20/32-2	53T2032	6W		32	200,85	-	110	38	53	18	
	53T20/36-2	53T2036	6W		36	226,35	-	110	38	53	18	
	53T20/40-2	53T2040	6A		40	251,80	-	110	38	53	20	
	53T20/48-2	53T2048	6A		48	302,70	-	130	38	53	20	
	53T20/60-2	53T2060	6A		60	379,10	-	130	38	53	20	
	53T20/72-2	53T2072	6A		72	455,50	-	140	38	53	20	

(PASSO 20 mm) PER CINGHIA LARGHEZZA 50 mm  
(PITCH 20 mm) FOR BELT WIDTH 50 mm  
(Teilung 20 mm) fuer RIEMENBREITE 50 mm  
(PAS 20 mm) POUR COURROIES LARGEUR 50 mm  
(PASO 20 mm) PARA CORREAS ANCHO 50 mm

### T 20

	CODICE CODE SYMBOL FABRIKNUMMER CODE SYMBOLE NUMERO DE FABRICA	NOSTRO CODICE OUR CODE UNSER KODE NOTRE CODE NUESTRO CODIGO	TIPO TYPE TYP TYPE TIPO	TIPO FLANGIA FLANGES TYPE BORDSCHEIBEN TYP TYPE FLASQUES TIPO TAPETAS	N.DENTI N. OF TEETH ZAHNEZAHL N. BRE DE DENTS CANTIDAD DE DIENTES	De	Df	Dm	F	L	d	PESO WEIGHT GEWICHT POIDS PESO Kg
GHISA - CAST IRON - GUESSEISEN FONTE - FUNDICION	71T20/18-2	71T2018	6F	F38	18	111,75	120	80	56	71	18	
	71T20/20-2	71T2020	6F	F43	20	124,50	138	90	56	71	18	
	71T20/22-2	71T2022	6F	F46	22	137,20	146	90	56	71	18	
	71T20/24-2	71T2024	6F	F50	24	149,95	158	95	56	71	18	
	71T20/25-2	71T2025	6F	F52	25	156,30	168	95	56	71	18	
	71T20/30-2	71T2030	6F	F59	30	188,15	200	110	56	71	18	
	71T20/32-2	71T2032	6W		32	200,85	-	110	56	71	20	
	71T20/36-2	71T2036	6W		36	226,35	-	110	56	71	20	
	71T20/40-2	71T2040	6A		40	251,80	-	110	56	71	20	
	71T20/48-2	71T2048	6A		48	302,70	-	130	56	71	24	
	71T20/60-2	71T2060	6A		60	379,10	-	130	56	71	24	
	71T20/72-2	71T2072	6A		72	455,50	-	140	56	71	24	

(PASSO 20 mm) PER CINGHIA LARGHEZZA 100 mm  
(PITCH 20 mm) FOR BELT WIDTH 100 mm  
(Teilung 20 mm) fuer RIEMENBREITE 100 mm  
(PAS 20 mm) POUR COURROIES LARGEUR 100 mm  
(PASO 20 mm) PARA CORREAS ANCHO 100 mm

### T 20

	CODICE CODE SYMBOL FABRIKNUMMER CODE SYMBOLE NUMERO DE FABRICA	NOSTRO CODICE OUR CODE UNSER KODE NOTRE CODE NUESTRO CODIGO	TIPO TYPE TYP TYPE TIPO	TIPO FLANGIA FLANGES TYPE BORDSCHEIBEN TYP TYPE FLASQUES TIPO TAPETAS	N.DENTI N. OF TEETH ZAHNEZAHL N. BRE DE DENTS CANTIDAD DE DIENTES	De	Df	Dm	F	L	d	PESO WEIGHT GEWICHT POIDS PESO Kg
GHISA - CAST IRON - GUESSEISEN FONTE - FUNDICION	123T20/18-2	123T2018	6F	F38	18	111,75	120	80	108	123	24	
	123T20/20-2	123T2020	6F	F43	20	124,50	138	90	108	123	24	
	123T20/22-2	123T2022	6F	F46	22	137,20	146	90	108	123	24	
	123T20/24-2	123T2024	6F	F50	24	149,95	158	95	108	123	24	
	123T20/25-2	123T2025	6F	F52	25	156,30	168	95	108	123	24	
	123T20/30-2	123T2030	6F	F59	30	188,15	200	110	108	123	24	
	123T20/32-2	123T2032	6W		32	200,85	-	110	108	123	32	
	123T20/36-2	123T2036	6W		36	226,35	-	110	108	123	32	
	123T20/40-2	123T2040	6A		40	251,80	-	110	108	123	32	
	123T20/48-2	123T2048	6A		48	302,70	-	130	108	123	32	
	123T20/60-2	123T2060	6A		60	379,10	-	130	108	123	32	
	123T20/72-2	123T2072	6A		72	455,50	-	140	108	123	32	

**Barre dentate standard**  
**Standard toothed bars**  
**Standard Zahnriemensstagen**  
**Barreaux dentés standard**  
**Barras dentadas de serie**

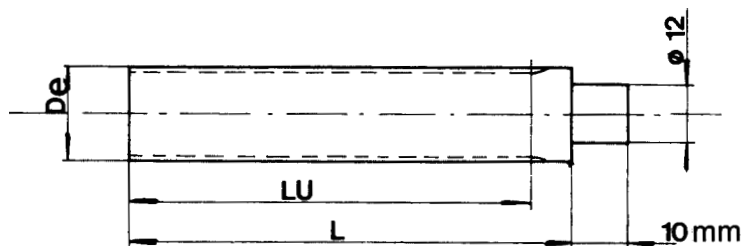

**Materiale: alluminio 6082 T6 UNI 9006/4 adatto al trattamento anodico**  
**Material: aluminium 6082 T6 UNI 9006/4 suitable for anodic treatment**  
**Material: aluminium 6082 T6 UNI 9006/4 geeignet für anodischen oxydation**  
**Material: aluminium 6082 T6 UNI 9006/4 apte au traitement anodique**  
**Material: aluminio 6082 T6 UNI 9006/4 apto para la oxidacion anodica**

<b>T 2,5</b> (PASSO 2,5 mm) (PITCH 2,5 mm) (TEILUNG 2,5 mm) (PAS 2,5 mm) (PASO 2,5 mm)				<b>T 5</b> (PASSO 5 mm) (PITCH 5 mm) (TEILUNG 5 mm) (PAS 5 mm) (PASO 5 mm)				<b>T 10</b> (PASSO 10 mm) (PITCH 10 mm) (TEILUNG 10 mm) (PAS 10 mm) (PASO 10 mm)									
CODICE CODE SYMBOL FABRIKNUMMER CODE SYMBOLE NUMERO DE FABRICA	NOSTRO CODICE OUR CODE UNSER KODE NOTRE CODE NUESTRO CODIGO	N.DENTI N. OF TEETH ZAHNEZAHL N. BRE DE DENTS CANTIDAD DE DIENTES	De	Lu	L	CODICE CODE SYMBOL FABRIKNUMMER CODE SYMBOLE NUMERO DE FABRICA	NOSTRO CODICE OUR CODE UNSER KODE NOTRE CODE NUESTRO CODIGO	N.DENTI N. OF TEETH ZAHNEZAHL N. BRE DE DENTS CANTIDAD DE DIENTES	De	Lu	L	CODICE CODE SYMBOL FABRIKNUMMER CODE SYMBOLE NUMERO DE FABRICA	NOSTRO CODICE OUR CODE UNSER KODE NOTRE CODE NUESTRO CODIGO	N.DENTI N. OF TEETH ZAHNEZAHL N. BRE DE DENTS CANTIDAD DE DIENTES	De	Lu	L
T2,5-10	BT25010	10	7,42	50	75	T5-10	BT05010	10	15,05	125	140	T10-10	BT10010	10	29,98	140	140
T2,5-12	BT25012	12	9,00	50	75	T5-11	BT05011	11	16,65	125	140	T10-11	BT10011	11	33,16	140	140
T2,5-13	BT25013	13	9,80	50	75	T5-12	BT05012	12	18,25	125	140	T10-12	BT10012	12	36,35	140	140
T2,5-14	BT25014	14	10,60	50	75	T5-13	BT05013	13	19,85	125	140	T10-13	BT10013	13	39,50	140	140
T2,5-15	BT25015	15	11,40	50	75	T5-14	BT05014	14	21,45	132	140	T10-14	BT10014	14	42,70	160	160
T2,5-16	BT25016	16	12,20	50	75	T5-15	BT05015	15	23,05	132	140	T10-15	BT10015	15	45,90	160	160
T2,5-17	BT25017	17	13,00	50	75	T5-16	BT05016	16	24,60	140	140	T10-16	BT10016	16	49,10	160	160
T2,5-18	BT25018	18	13,80	50	75	T5-17	BT05017	17	26,20	140	140	T10-17	BT10017	17	52,25	160	160
T2,5-19	BT25019	19	14,60	90	120	T5-18	BT05018	18	27,80	140	140	T10-18	BT10018	18	55,45	160	160
T2,5-20	BT25020	20	15,40	90	120	T5-19	BT05019	19	29,40	140	140	T10-19	BT10019	19	58,65	160	160
T2,5-21	BT25021	21	16,20	90	120	T5-20	BT05020	20	31,00	160	160	T10-20	BT10020	20	61,80	160	160
T2,5-22	BT25022	22	17,00	125	140	T5-21	BT05021	21	32,70	160	160	T10-21	BT10021	21	65,00	160	160
T2,5-24	BT25024	24	18,55	125	140	T5-22	BT05022	22	34,15	160	160	T10-22	BT10022	22	68,20	160	160
T2,5-26	BT25026	26	20,15	125	140	T5-23	BT05023	23	35,85	160	160	T10-23	BT10023	23	71,35	160	160
T2,5-27	BT25027	27	20,95	125	140	T5-24	BT05024	24	37,40	160	160	T10-24	BT10024	24	74,55	160	160
T2,5-28	BT25028	28	21,75	125	140	T5-25	BT05025	25	38,95	160	160	T10-26	BT10026	26	80,90	160	160
T2,5-29	BT25029	29	22,55	125	140	T5-26	BT05026	26	40,60	160	160	T10-28	BT10028	28	87,25	160	160
T2,5-30	BT25030	30	23,35	125	140	T5-27	BT05027	27	42,20	160	160	T10-30	BT10030	30	93,65	160	160
T2,5-32	BT25032	32	24,95	125	140	T5-28	BT05028	28	43,75	160	160	T10-32	BT10032	32	100,00	160	160
T2,5-34	BT25034	34	26,55	125	140	T5-29	BT05029	29	45,35	160	160	T10-34	BT10034	34	106,40	160	160
T2,5-35	BT25035	35	27,35	132	140	T5-30	BT05030	30	46,95	160	160	T10-36	BT10036	36	112,75	160	160
T2,5-36	BT25036	36	28,10	132	140	T5-32	BT05032	32	50,10	160	160	T10-38	BT10038	38	119,10	160	160
T2,5-38	BT25038	38	29,70	132	140	T5-34	BT05034	34	53,25	160	160	T10-40	BT10040	40	125,45	160	160
T2,5-40	BT25040	40	31,30	132	140	T5-35	BT05035	35	54,85	160	160	T10-45	BT10045	45	141,40	160	160
T2,5-42	BT25042	42	32,90	140	140	T5-36	BT05036	36	56,45	160	160	T10-48	BT10048	48	150,95	160	160
T2,5-44	BT25044	44	34,50	140	140	T5-37	BT05037	37	58,06	160	160	T10-60	BT10060	60	189,10	160	160
T2,5-45	BT25045	45	35,30	140	140	T5-38	BT05038	38	59,65	160	160	T10-72	BT10072	72	227,29	160	160
T2,5-48	BT25048	48	37,70	140	140	T5-40	BT05040	40	62,85	160	160						
T2,5-50	BT25050	50	39,29	160	160	T5-42	BT05042	42	66,00	160	160						
T2,5-60	BT25060	60	47,25	160	160	T5-44	BT05044	44	69,20	160	160						
T2,5-65	BT25065	65	51,20	160	160	T5-45	BT05045	45	70,80	160	160						
T2,5-70	BT25070	70	55,20	160	160	T5-46	BT05046	46	72,40	160	160						
T2,5-72	BT25072	72	56,80	160	160	T5-48	BT05048	48	75,55	160	160						
T2,5-90	BT25090	90	71,12	160	160	T5-50	BT05050	50	78,75	160	160						
T2,5-100	BT25100	100	79,08	160	160	T5-60	BT05060	60	94,65	160	160						
						T5-72	BT05072	72	113,75	160	160						
						T5-80	BT05080	80	126,48	160	160						
						T5-90	BT05090	90	142,40	160	160						
						T5-100	BT05100	100	158,31	160	160						

PER BARRE CON N. DI DENTI NON INCLUSI IN QUESTE TAVOLE, CHIEDERE PER QUOTAZIONE  
 FOR BARS WITH A NUMBER OF TEETH NOT INCLUDED IN THESE TABLES PLEASE ASK FOR OUR QUOTATION  
 VERLANGEN SIE ANGEBOT FUER STANGEN MIT ANZAHL VON ZAEHNEN DIE NICHT IN DIESEN TAFELN AUFGEFUEHRT SIND  
 POUR LES BARREAUX AVEC UN NOMBRE DE DENTS DIFFERENT DU TABLEAU, NOUS CONSULTER  
 PIDAN OFERTA POR LO QUE CONCIERNE UNA CANDIDAD DE DIENTES NO INCLUIDA EN ESTAS TABLAS



N. DENTI N. OF TEETH ZÄHNEZAHL NOMBRE DE DENTS CANTIDAD DE DIENTES	FLANGIA - FLANGES - BORDSCHEIBEN - FLASQUES - TAPETAS				TIPO FLANGIA FLANGES TYPE BORDSCHEIBEN TYP TYPE FLASQUES TIPO TAPETAS			
	d = 0,5 mm	d = 1 mm	d = 1 mm	d = 1,5 mm				
	T 2,5	T 5	T 10	T 20				
8	-	-	-	-	F 01	13	10	6
9	-	-	-	-	F 02	15	12	8
10	-	F 06	-	-	F 03	16	13	9,5
11	-	-	-	-	F 04	17,5	14,5	11,6
12	F 01	F 07	F 15	-	F 05	18	15	11,5
13	-	-	-	-	F 06	20	16,5	12,2
14	F 02	F 08	F 18	-	F 07	23	18	12,5
15	F 02	F 09	F 19	-	F 08	25	21,5	15
16	F 03	F 10	F 20	-	F 09	28	24	17,8
17	-	-	-	-	F 10	32	27,5	23
18	F 04	F 10	F 22	F 38	F 11	35	30,5	23
19	F 05	F 12	F 25	-	F 12	36	31	25
20	F 06	F 12	F 25	F 43	F 13	37	33	25
21	-	-	-	-	F 14	38	34	26,5
22	F 07	F 14	F 27	F 46	F 15	42	38	30,5
23	-	-	-	-	F 16	43	39	31
24	F 07	F 15	F 29	F 50	F 17	44	40,5	32,5
25	F 07	F 17	F 29	F 52	F 18	48	43,5	37
26	F 08	F 17	F 30	-	F 19	51	47	40
27	-	F 18	F 31	-	F 20	54	50,5	43
28	F 08	F 18	F 32	-	F 21	57	52	46
29	-	-	-	-	F 22	60	57	47
30	F 09	F 19	F 33	F 59	F 23	61	56,5	49
31	-	-	-	-	F 24	64	57	47
32	F 10	F 20	F 35	-	F 25	66	63	52
33	-	-	-	-	F 26	70	66,5	53
34	-	-	-	-	F 27	75	68,5	60
35	-	-	-	-	F 28	79	72,5	60
36	F 12	F 24	F 38	-	F 29	83	78	68
37	-	-	-	-	F 30	87	82,5	72
38	-	-	-	-	F 31	91	85,5	76
39	-	-	-	-	F 32	93	89	80
40	F 14	F 25	F 41	-	F 33	97	93,8	83
41	-	-	-	-	F 34	102	97	82,5
42	-	F 26	-	-	F 35	106	101	90
43	-	-	-	-	F 36	112	105,5	91
44	F 15	-	-	-	F 37	115	109	94
45	-	-	-	-	F 38	120	112,5	99,5
46	-	-	-	-	F 39	123	117,5	107
47	-	-	-	-	F 40	128	124	107
48	-	-	-	-	F 41	131	125,5	115
49	-	-	-	-	F 42	135	128,5	115
50	-	-	-	-	F 43	138	132	121
51	-	-	-	-	F 44	140	125	107
52	-	-	-	-	F 45	142	137	120
53	-	-	-	-	F 46	146	133	107
54	-	-	-	-	F 47	148	143	132
55	-	-	-	-	F 48	150	145	130
56	-	-	-	-	F 49	154	142	122
57	-	-	-	-	F 50	158	153	138,5
58	-	-	-	-	F 51	160	148	120
59	-	-	-	-	F 52	168	161	148
60	-	-	-	-	F 53	175	170	157
61	-	-	-	-	F 54	180	174	154
62	-	-	-	-	F 55	184	168	135
63	-	-	-	-	F 56	188	176	150
64	-	-	-	-	F 57	192	187	173
65	-	-	-	-	F 58	198	180	150
66	-	-	-	-	F 59	200	193	180
					F 60	205	189	160
					F 61	212	200	162
					F 62	226	214	190
					F 63	230	222	200
					F 64	240	224	192
					F 65	250	228	200
					F 66	256	240	220
					F 67	265	240	213
					F 68	275	253	225
					F 69	286	277	242
					F 70	296	287	260
					F 71	300	280	252
					F 72	325	305	278
					F 73	350	330	302
					F 74	375	355	328
					F 75	405	380	354
					F 76	430	406	380
					F 77	455	432	405
					F 78	480	457	430
					F 79	530	508	481
					F 80	595	572	544