

ESTUN

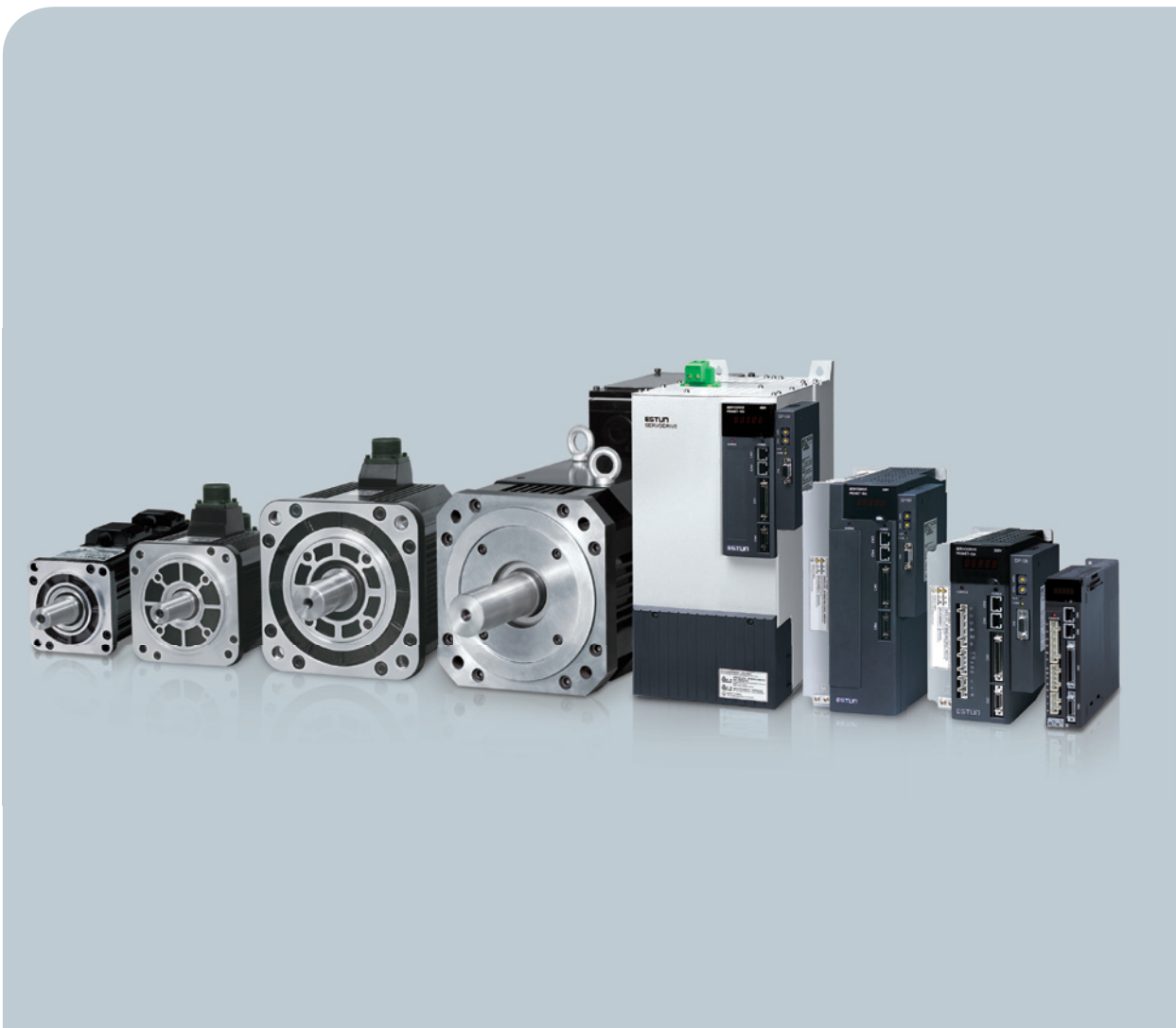

ProNet

All Digital AC Servo Systems



ISO9001

As a national support prior AC servo system research, development and production base, Estun Automation is devoted to R&D, manufacturing and sales of high-end products in the realm of motion control. We are holding completely with self-owned IPR technology of our AC servo systems which can be applied in CNC machine, textile machine, packing machine, printing machine, wood-working machine, robotization production line, electro-hydraulic hybrid-driven and fully electrical injection moulding machine, etc. Now, Estun has established long-term strategy cooperation with many prestigious machine manufacturers and become their first cooperation option for motion control products home and abroad.



- 04 General Introduction
- 06 Servo Drive Specification
- 09 Communication
- 12 Servo Motor Specification
- 20 Installation Diagrams
- 30 Connection
- 35 Accessories



General Introduction

ProNet Series AC Servo System

Features



- Wide range, various models : 0.2kW ~ 22kW
- Current forward feedback control, acceleration forward-feed : high responsiveness
- Auto tuning function, online real time load inertia inspecting : simple setting
- Multiple feedback options : 17bits serials encoder, 2500P/R encoder, resolver
- Various communication protocols : CANopen, EtherCAT, POWERLINK, PROFIBUS, Modbus
- ProNet-E series : huge market competitiveness
- Universal servo : widely used in various industries covering CNC machine tool, router machine, wood making machine, packing machine, textile machine, printing machine, robot arm, medical machine, jewelry making machine, 3D cinema chair, car simulating machine, etc.
- Three phase 400V power supply models are available from 1kW to 22kW
- Low frequency vibration suppression function, with excellent performance at low speed movement
- New homing function available under position control mode
- Dynamic electronic gear ratio switching function

Typical application

- Electronic devices
- CNC machine (lathe,milling machine,grinder,machining center, etc.)
- Packaging machine(pillow type packaging machine,seal packaging machine,liquid filling machine, etc.)
- Textile machine(quilting machine,tricot machine,cross knitting machine, etc.)
- Printing machine (gravure printing machine,flat-bed printing machine,letterpress printer, etc.)
- Robot (manipulator,industrial robotics, etc.)

...

Model Comparison Table

Servo Motor				Servo Drive (ProNet)		Servo Drive (ProNet-E)		
Series		Power	Model	Three-phase 200VAC Single-phase 200VAC (0.2kW-1.5kW)	Three-phase 400VAC	Three-phase 200VAC Single-phase 200VAC (0.2kW-1.5kW)		
Medium Inertia	Small	EMJ 3000r/min	0.2kW	EMJ-02	ProNet-02		ProNet-E-02	
			0.4kW	EMJ-04	ProNet-04		ProNet-E-04	
			0.75kW	EMJ-08	ProNet-08		ProNet-E-08	
			1.0kW	EMJ-10	ProNet-10		ProNet-E-10	
	Medium	EMG 2000r/min	1.0kW	EMG-10	ProNet-10		ProNet-E-10	
			1.5kW	EMG-15	ProNet-15		ProNet-E-15	
			2.0kW	EMG-20	ProNet-20		ProNet-E-20	
			3.0kW	EMG-30	ProNet-30		ProNet-E-30	
			5.0kW	EMG-50	ProNet-50		ProNet-E-50	
			EML 1000r/min	1.0kW	EML-10	ProNet-10		ProNet-E-10
				2.0kW	EML-20	ProNet-20		ProNet-E-20
				3.0kW	EML-30	ProNet-30		ProNet-E-30
	4.0kW	EML-40		ProNet-50		ProNet-E-50		
	Large	EMB 1500r/min	7.5kW	EMB-75		ProNet-75		
			11kW	EMB-1A		ProNet-1A		
			15kW	EMB-1E		ProNet-1E		
22kW			EMB-2B		ProNet-2B			

Servo Drive Specification

Specification Description

ProNet – 10

ProNet Servo Drive

Rated Power

A

Power Voltage

M

Control Style

A

Encoder Interface

Extended Module

Sign	Spec.	Sign	Spec.	Sign	Spec.	Sign	Spec.	Sign	Spec.
02	0.2kW	A	200VAC	M	Speed Control, Torque Control, Position Control	A	17 Bits Serial Encoder		None
04	0.4kW	D	400VAC					-D	DP100
08	0.75kW			E	Speed Control, Torque Control, Position Control (Support Extended Module)	B	Resolver	-E	EC100
10	1.0kW							-P	PL100
15	1.5kW								
20	2.0kW								
30	3.0kW								
50	5.0kW								
75	7.5kW								
1A	11kW								
1E	15kW								
2B	22kW								

ProNet-E – 10

ProNet-E Servo Drive

Rated Power

A

Power Voltage

Sign	Spec.	Sign	Spec.
02	0.2kW	A	200VAC
04	0.4kW		
08	0.75kW		
10	1.0kW		
15	1.5kW		
20	2.0kW		
30	3.0kW		
50	5.0kW		

Notes:

- ① ProNet-E is only equipped with wire-saving incremental encoder (2500P/R).
- ② ProNet-E does not support extended module.



Ratings

Servo Drive Model	ProNet-	02A	04A	08A	10A	10D	15A	15D	20A	30A	50A	75D	1AD	1ED	2BD
	ProNet-E														
Applicable Servo Motors Model	EMJ-	02	04A	08A	10A	-	-	-	-	-	-	-	-	-	-
	EMG-	-	-	-	10A	10D	15A	15D	20A	30A	50A	-	-	-	-
	EML-	-	-	-	10A	10D	-	-	20A	30A	40A	-	-	-	-
	EMB-	-	-	-	-	-	-	-	-	-	-	75D	1AD	1ED	2BD
Continuous Output Current		1.4	2.8	4.0	6.0	3.0	9.0	4.8	12.0	18.0	28.0	18.0	28.0	38.0	55.0
Max. Output Current		4.2	8.4	12.0	18.0	9.0	28.0	14.4	42.0	56.0	84.0	56.0	70.0	84.0	138.0
Input Power Supply Capacity		0.5	0.9	1.3	1.8	1.8	2.5	2.5	3.5	4.5	7.5	12.0	18.0	22.0	32.0

Specification

Items			Specifications
Input Power Supply	Main Circuit	200V	Three-phase 200 to 230VAC 50/60Hz (0.2kW-5.0kW)
		400V	Three-phase 380 to 440VAC 50/60Hz (1.0kW-1.5kW, 7.5kW-22kW)
	Control Circuit	200V	Single-phase 200 to 230VAC 50/60Hz (0.2kW-5.0kW)
		400V	Single-phase 380 to 440VAC 50/60Hz (1.0kW-1.5kW, 7.5kW-22kW)
Control Method			SVPWM Control
Feedback			Serial Encoder: 131072P/R Resolver Wire-saving Incremental Encoder (2500P/R)
Operating Conditions	Ambient / Storage Temperature		Ambient Temperature: 0 to +55°C, Storage Temperature: -20 to +85°C
	Ambient / Storage Humidity		90% RH or less (no condensation)
	Elevation		1000m or less
	Vibration / Impact Resistance		Vibration Resistance: 4.9m/s ² , Impact Resistance: 19.6m/s ²
Configuration			Base-mounted
Performance	Speed Control Range		1:5000
	Speed Regulation	Load Regulation	0 to 100% load: ±0.01% max. (at rated speed)
		Voltage Regulation	Rated voltage, ±10%: 0% (at rated speed)
		Temperature Regulation	25±25°C: ±0.1% max. (at rated speed)
Torque Control	Analog Input	Reference Voltage	±10VDC at rated torque (variable setting range: ±0 to 10VDC) Max. input voltage: ±12V
		Input Impedance	About 10MΩ min.
		Circuit Time Constant	10μs

Next

Items		Specifications	
Speed Control	Analog Input	Reference Voltage	±10VDC at rated torque (variable setting range: ±0 to 10VDC) Max. input voltage: ±12V
		Input Impedance	About 10MΩ min.
		Circuit Time Constant	10μs
	Set Speed Reference	Speed Selection	Speed 1 to 7 selection
Function	Soft Start Setting	0 to 10s (can be set individually for acceleration and deceleration)	
Position Control	Reference Pulse	Type	Sign+pulse train, CCW+CW pulse train, or 90° phase difference 2-phase pulse (phase A + phase B)
		Form	Non-insulated line driver (+5V level), open collector
		Frequency	x1 multiplier: 4Mpps x2 multiplier: 2Mpps x4 multiplier: 1Mpps Open collector: 200kpps Frequencies drop when the duties have errors
	Set Position Reference	Position Setting	Can set 16 position reference
I/O Signals	Encoder Output Pulses		Phase A, phaseB, phase C: line driver output The number of dividing pulse: Any setting ratio is available
	Sequence Input	Number of Channels	8 channels
		Function	Signal allocations and positive/negative logics can be modified: Servo ON (/S-ON), P control (/P-CON), alarm reset (/ALM-RST), clear error pulse (/CLR), forward run prohibited (P-OT), reverse run prohibited (N-OT), forward torque limit (/P-CL), reverse torque limit (/N-CL)
	Sequence Output	Number of Channels	4 channels
Function		Servo alarm (ALM) Signal allocations and positive/negative logics can be modified: Positioning completion (/COIN), speed agree detection (/V-CMP), motor rotation detection (/TGON), servo ready (/S-RDY), torque limit detection (/CLT), brake interlock (/BK), encoder C pulse (/PGC), over travel signal (/OT)	
Built-in Functions	Dynamic Brake (DB) Functions		Operates during main power OFF, servo alarm, servo OFF or overtravel
	Regenerative Processing Functions		750W to 5.0kW: built-in regenerative resistor; 7.5kW to 22kW: External regenerative resistor (optional)
	Protective Functions		Overcurrent, overvoltage, low voltage, overload, regeneration error, overspeed, etc.
	Utility Functions		Alarm trace back, JOG operation, Inertia detections, etc.
	Display Functions		CHARGE (red), POWER (green), 7-segment 5-digit LED (Built-in digital operator function)
	Communications		RS-485 communication port, use Modbus protocol. CAN communication port, use CANopen protocol.

Communication

EtherCAT



EtherCAT Module

- High communication speed
- Precise multiple axis synchronous control
- Revolution of traditional field bus control

Items	Specifications
Communication standard	IEC 61158 Type12, IEC 61800-7 CiA402 Drive Profile
Physical layer	100BASE-TX (IEEE802.3)
Bus connection	CN4 (RJ45): EtherCAT Signal IN CN5 (RJ45): EtherCAT Signal OUT
Cable	Class-5 twisted pair cable
Communication distance	Node space: within 100 meters
SyncManager	SM0: output mailbox, SM1: input mailbox SM2: output process data, SM3: input process data
FMMU	FMMU0: mapping to process data (RxPDO) Receiving area FMMU1: mapping to process data (TxPDO) Transmitting area FMMU2: mapping to mailbox status
EtherCAT Commands (Data Link Layer)	APRD, FPRD, BRD, LRD, APWR, FPWR, BWR, LWR, ARMW, FRMW Note: APRW, FPRW, BRW, LRW Commands are not supported
PDO data	Dynamic PDO mapping
Mailbox (CoE)	Emergency event, SDO request, response, SDO information Note: do not support TxPDO/RxPDO and remote TxPDO/RxPDO
Differential clock (DC)	Free-run , DC mode (set active in configuration) Supported DC period : 250us - 8ms
SII	256 bytes (read - only)
LED Indicator	EtherCAT System indicator (SYS) x1 EtherCAT Run indicator (RUN) x1 EtherCAT Error indicator (ERR) x1
CiA402 Drive Profile	Homing mode, Profile position mode, Interpolated position mode, Profile velocity mode, Cyclic synchronous position mode

CANopen



Standard CAN bus interfaces are available in ProNet series servo drives, which makes it easy to get integrated into a distributed control system.

Items	Specifications
Communication standard	CiA-DS301 CiA402 Drive Profile
Physical layer	ISO 11898-2 CiA 303-1
Bus connection	CN3 (RJ45): Signal IN CN4 (RJ45): Signal OUT
Cable	Twisted pair cable
Baud rate	50Kbps, 100Kbps, 125Kbps, 250Kbps, 500Kbps, 1Mbps
COB	SDO, PDO, SYNC, EMCY, NMT, Heartbeat
Control mode	Homing mode, speed control mode, position control mode, position interpolation mode
PDO data	Dynamic PDO mapping, 2 sending PDO, 2 receiving PDO

POWERLINK



POWERLINK technology applied in ProNet series drives leads to improved performances and expanded application fields. POWERLINK is open source technology and has no platform limit. It is CANopen over Ethernet, which has inherited all former applications based on CANopen. Customer programs are protected and performance level is increased. POWERLINK drive provides fast and realtime response ability of 250 μ s, which definitely gives better support for applications like high speed synchronization, high speed positioning control and electronic gear, etc.

Items	Specifications	
POWERLINK	Communication standard	IEC 61784-2, IEC 61800-7 CiA402 Drive Profile
	Physical layer	100BASE-TX (IEEE802.3)
	Bus connection	CN5 (RJ45): POWERLINK Signal IN/OUT CN6 (RJ45): POWERLINK Signal IN/OUT
	Cable	Class-5 twisted pair cables
	PDO data	Dynamic PDO mapping
	LED indicator	POWERLINK System indicator (SYS) \times 1 POWERLINK Run indicator (RUN) \times 1 POWERLINK Error indicator (ERR) \times 1
Communication Mode	Homing mode Profile position mode Profile velocity mode Interpolation position mode	

PROFIBUS



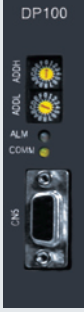

DP100

Code Switch Address Setting

Alarm Light

Communication Light

Profibus Connection End

Profibus Module

6	+5V
3	RS485-B
8	RS485-A
5	GND

There are many applications based on profibus communication in industrial automation market. DP100 module is a PROFIBUS DP module, which can connect the other PROFIBUS products with ESTUN ProNet servo drive, and the project cost of providing profibus connection is low.

Items	Specifications
Communication standard	PROFIBUS-DP,PROFIDRIVE
Physical layer	RS-485 transmission
Bus connection	CN5 (DB9)
Cable	RS-485 cable with D type
Baud rate	Automatic identification of bus transmission baud rate Communication distance: 9.6Kbps~12Mbps Transmission distance: 100m~1200m
Data exchange	Cyclic data exchange and Acyclic data exchange
LED indicator	ALM, COMM
Address setting	ADDH, ADDL

Modbus

Modbus

- ProNet series servo drives provide the Modbus communication function with RS-485 interface
- Which can be used to easily set parameters or to perform monitoring operations and so on

Items	Specifications
Communication standard	Modbus
Physical layer	RS-485 transmission
Bus connection	CN3 (RJ45): Signal IN CN4(RJ45): Signal OUT
Cable	Twisted pair cable
Baud rate	4800bps, 9600bps, 19200bps
Communication Mode	ASCII, RTU

Servo Motor Specification

EMJ Model

Features

- Medium inertia
- Peak torque up to 300% of rated torque
- Various models (0.2kW~1.0kW, with brake, etc.)
- Run at speed of up to 4500r/min
- Mounted 17 bits incremental / absolute encoder, Optional mounted wire-saving incremental encoder (2500P/R)

Application

- SMM (surface mounting machine)
- Pcb puncher machine
- Robot arm
- Handling machinery
- Foodstuff processing machinery
- Textile machinery



Specification Description

EMJ - 08 A D B 1 1 -WR

EMJ Model
Servo Motor

Rated Output
Power

Power
Voltage

Encoder

Designing
Sequence

Shaft End

Option Parts

Connector

Sign	Spec.	Sign	Spec.	Sign	Spec.	Sign	Spec.	Sign	Spec.	Sign	Spec.
02	0.2kW	A	200VAC	D	Incremental Encoder: 131072P/R	A, B Designing Sequence	1	Flat, Without Keys (Standard)	1	None	-WR Waterproof Connector
04	0.4kW			S	Absolute Encoder: 131072P/R		2	Flat, With Keys, With Screw Thread	2	With Oil Seal	
08	0.75kW			R	Resolver		3	With Brake (DC24V)			
10	1.0kW			P	Incremental Wire-saving Type: 2500P/R		4	With Oil Seal, With Brake (DC24V)			

Notes: There is no brake in EMJ-□□AD□□□ servo motor.

Rated Value and Specification

Voltage		200VAC			
Servo Motor Model	EMJ-	02A□A□□	04A□B□□	08A□B□□	10A□B□□
Rated Output Power	kW	0.2	0.4	0.75	1.0
Rated Torque	N.m	0.64	1.27	2.39	3.18
Instantaneous Peak Torque	N.m	1.91	3.82	7.16	9.55
Rated Current	Arms	1.4	2.8	4.0	5.3
Instantaneous Max Current	Arms	4.2	8.4	12.0	15.9
Rated Speed	r/min	3000			
Max. Speed	r/min	4500			
Rotor Moment of Inertia	X10 ⁻⁴ kg·m ²	0.19 (0.23)	0.31 (0.35)	1.35 (1.47)	1.74 (1.87)
Brake Rated Voltage		DC24V±10%			
Brake Rated Power	W	7.2		11.5	
Brake Holding Torque	N.m	1.3		3.2	
Encoder	Standard	Incremental Encoder: 131072P/R			
	Options	Absolute Encoder: 131072P/R Wire-saving Incremental Encoder (2500P/R)			
Insulation Class		F			
Ambient Temperature		0 to + 40°C (no freezing)			
Ambient Humidity		20 to 80% RH (non-condensing)			
Vibration		49m/s ²			
Enclosure		Totally Enclosed, Self-cooled, IP65 (Except for shaft opening, when not equipped with oil seal; Except for connectors, when not equipped with waterproof connectors.)			

(Note) The values in parentheses are for servo motors with holding brakes.

Torque-Speed Feature

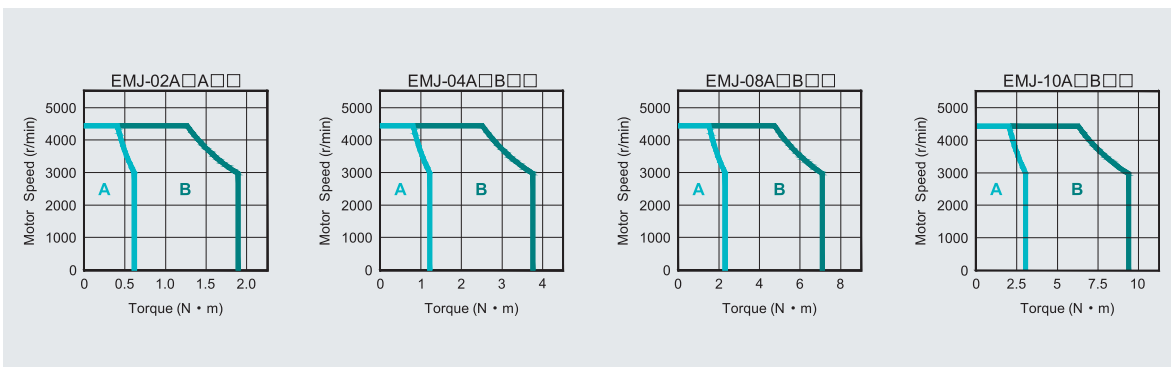

A: Continuous Working Area B: Repeatedly Working Area

Servo Motor Specification

EMG Model

Features

- Be used to drive the feed shaft of various machinery
- Various products (1.0kW~5.0kW, with brake, etc.)
- Mounted 17 bits incremental / absolute encoder, Optional mounted resolver or wire-saving incremental encoder (2500P/R)
- Standard configuration is IP65

Application

- Machine tools
- Handling machinery
- Foodstuff processing machinery
- Textile machinery



Specification Description

EMG-10

EMG Model
Servo Motor

A

Rated Output
Power

D

Encoder

A

Designing
Sequence

1

Shaft End

1

Option Parts

Sign	Spec.	Sign	Spec.	Sign	Spec.	Sign	Spec.	Sign	Spec.	Sign	Spec.
10	1.0kW	A	200VAC	D	Incremental Encoder: 131072P/R	A	Designing Sequence	1	Flat, Without Keys (Standard)	1	None
15	1.5kW	D	400VAC	S	Absolute Encoder: 131072P/R			2	Flat, With Keys With Screw Thread	2	With Oil Seal
20	2.0kW			R	Resolver					3	With Brake (DC24V)
30	3.0kW			P	Incremental Wire-saving Type: 2500P/R					4	With Oil Seal, With Brake (DC24V)
50	5.0kW										

Notes: 1. The EMG-30A□□□□, EMG-50A□□□□ servo motors are not mounted the incremental encoder.
 2. There is no brake in EMG-□□□□DA□□ servo motor.
 3. EMG-10/15 servo motor adds the supply voltage of 400V models.

Rated Value and Specification

Voltage		200VAC / 400VAC						
Servo Motor Model	EMG-	10A□A□□	10D□A□□	15A□A□□	15D□A□□	20A□A□□	30A□A□□	50A□A□□
Rated Output Power	kW	1.0	1.0	1.5	1.5	2.0	3.0	5.0
Rated Torque	N.m	4.78	4.78	7.16	7.16	9.55	14.3	23.9
Instantaneous Peak Torque	N.m	14.3	14.3	21.5	21.5	28.7	43.0	71.6
Rated Current	Arms	6.0	3.0	9.0	4.8	12.0	18.0	28.0
Instantaneous Max. Current	Arms	18.0	9.0	27.0	14.4	36.0	54.0	84.0
Rated Speed	r/min	2000						
Max. Speed	r/min	3000						
Rotor Moment of Inertia	$\times 10^{-4} \text{kg} \cdot \text{m}^2$	10.0 (10.6)		14.5 (15.1)		19.0 (19.6)	41.3 (44.5)	65.7 (68.9)
Brake Rated Voltage		DC24V±10%						
Brake Rated Power	W	19					35	
Brake Holding Torque	N.m	10					40	
Encoder	Standard	Incremental Encoder: 131072P/R				Absolute Encoder: 131072P/R		
	Options	Absolute Encoder: 131072P/R Resolver Wire-saving Incremental Encoder (2500P/R)				Resolver		
Insulation Class		F						
Ambient Temperature		0 to + 40°C (No freezing)						
Ambient Humidity		20 to 80% RH (Non-condensing)						
Vibration		24.5m/s ²						
Enclosure		Totally Enclosed, Self-cooled, IP65 (Except for shaft opening, when not equipped with oil seal.)						

(Note) The values in parentheses are for servo motors with holding brakes.

Torque-Speed Feature

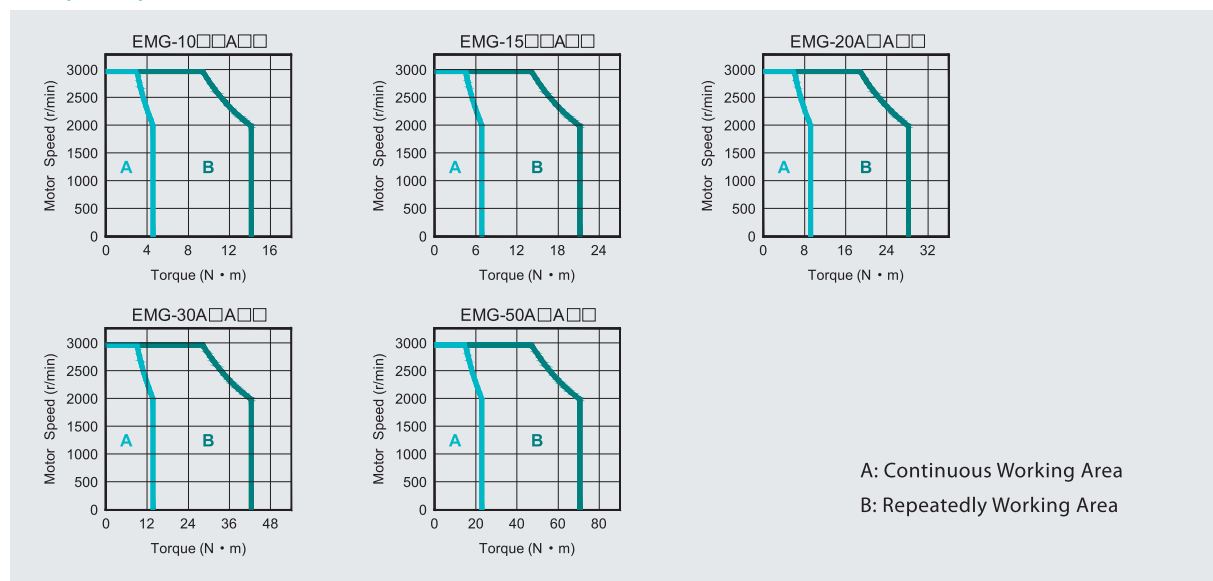

Servo Motor Specification

EML Model

Features

- Be used to drive the feed shaft of various machinery
- Various products (1.0kW~4.0kW, with brake, etc.)
- Mounted 17 bits incremental / absolute encoder, Optional mounted resolver or wire-saving incremental encoder (2500P/R)
- Standard configuration is IP65

Application

- Machine tools
- Handling machinery
- Foodstuff processing machinery
- Textile machinery



Specification Description

EML-10

EML Model
Servo Motor

A

Rated Output
Power

D

Encoder

A

Designing
Sequence

1

Shaft End

1

Option Parts

Sign	Spec.	Sign	Spec.	Sign	Spec.	Sign	Spec.	Sign	Spec.	Sign	Spec.
10	1.0kW	A	200VAC	D	Incremental Encoder: 131072P/R	A	Designing Sequence	1	Flat, Without Keys (Standard)	1	None
20	2.0kW	D	400VAC	S	Absolute Encoder: 131072P/R	2		Flat, With Keys With Screw Thread	2	With Oil Seal	
30	3.0kW			R	Resolver				3	With Brake (DC24V)	
40	4.0kW			P	Incremental Wire-saving Type: 2500P/R				4	With Oil Seal, With Brake (DC24V)	

- Notes: 1. The EML-20A□A□□, EML-30A□A□□, EML-40A□A□□ servo motors are not mounted the incremental encoder.
 2. There is no brake in the EML-□□ADA□□ servo motor.
 3. EML-10 servo motor adds the supply voltage of 400V models.

Rated Value and Specification

Voltage		200VAC / 400VAC				
Servo Motor Model	EML-	10A□□□□	10D□□□□	20A□□□□	30A□□□□	40A□□□□
Rated Output Power	kW	1.0	1.0	2.0	3.0	4.0
Rated Torque	N.m	9.55	9.55	19.1	28.7	38.2
Instantaneous Peak Torque	N.m	28.7	28.7	57.3	86.0	114.6
Rated Current	Arms	6.0	3.0	12.0	18.0	24.0
Instantaneous Max. Current	Arms	18.0	9.0	36.0	54.0	72.0
Rated Speed	r/min	1000				
Max. Speed	r/min	1500				
Rotor Moment of Inertia	X10 ⁻⁴ kg·m ²	19.0 (19.6)		53.5 (56.7)	77.8 (81.0)	102.2 (105.4)
Brake Rated Voltage		DC24V±10%				
Brake Rated Power	W	19		35		
Brake Holding Torque	N.m	10		40		
Encoder	Standard	Incremental Encoder: 131072P/R		Absolute Encoder: 131072P/R		
	Options	Absolute Encoder: 131072P/R Resolver		Resolver		
		Wire-saving Incremental Encoder (2500P/R)				
Insulation Class		F				
Ambient Temperature		0 to + 40°C (No freezing)				
Ambient Humidity		20 to 80% RH (Non-condensing)				
Vibration		24.5m/s ²				
Enclosure		Totally Enclosed, Self-cooled, IP65 (Except for shaft opening, when not equipped with oil seal.)				

(Note) The values in parentheses are for servo motors with holding brakes.

Torque-Speed Feature

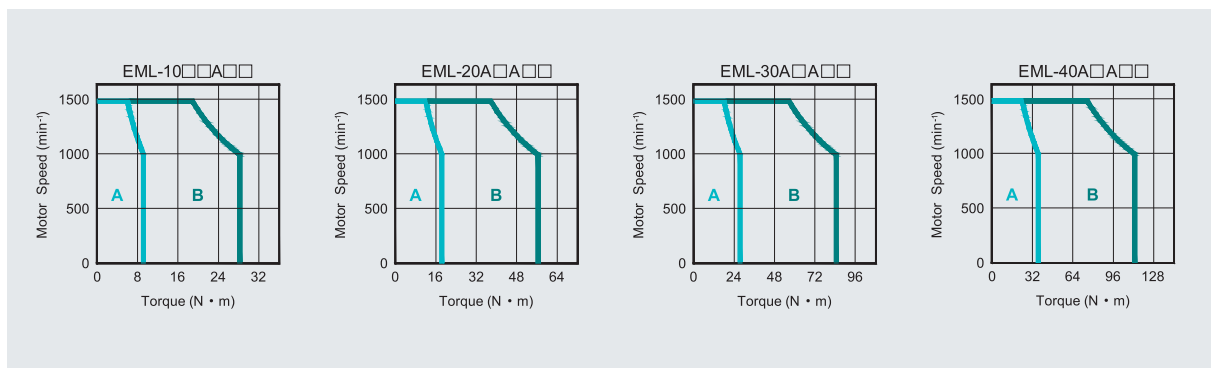

A: Continuous Working Area B: Repeatedly Working Area

Servo Motor Specification

EMB Model

Features

- Power supply voltage: 400V
- Driving of feed shafts for various machinery
- Various products (7.5kW~22kW, with brake, etc.)
- Mounted 17 bits absolute encoder, Optional mounted resolver
- Temperature sensor

Application

- Machine tools
- Handling machinery
- Foodstuff processing machinery
- Textile machinery

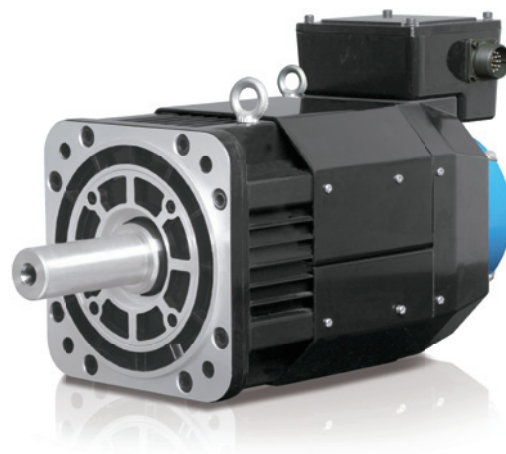

Specification Description

EMB-1E D

EMB Model
Servo Motor

Rated Output
Power

Power
Voltage

S

Encoder

A

Designing
Sequence

1

Shaft End

1

Option Parts

Sign	Spec.	Sign	Spec.	Sign	Spec.	Sign	Spec.	Sign	Spec.	Sign	Spec.
75	7.5kW	D	400VAC	S	Absolute Encoder: 131072P/R	A	Designing Sequence	1	Flat, Without Keys (Standard)	1	None
1A	11.0kW									2	With Oil Seal
1E	15.0kW			R	Resolver			2	Flat, With Keys With Screw Thread	3	With Brake (DC24V)
2B	22.0kW									4	With Oil Seal, With Brake (DC24V)

Rated Value and Specification

Voltage		400VAC			
Servo Motor Model	EMB-	75D□A□□	1AD□A□□	1ED□A□□	2BD□A□□
Rated Output Power	kW	7.5	11.0	15.0	22.0
Rated Torque	N.m	47.8	70.0	95.5	140.0
Instantaneous Peak Torque	N.m	143.4	175	191	350
Rated Current	Arms	18.0	28.0	38.0	52.0
Instantaneous Max. Current	Arms	56.0	70.0	84.0	130
Rated Speed	r/min	1500			
Max. Speed	r/min	2000			
Rotor Moment of Inertia	X10 ⁻⁴ kg·m ²	186.2 (193.6)	271.6 (278.9)	338.8 (346.1)	576.62
Brake Rated Voltage		DC24V±10%			
Brake Rated Power	W	90			
Brake Holding Torque	N.m	100			
Encoder	Standard	Absolute Encoder: 131072P/R			
	Options	Resolver			
Insulation Class		F			
Ambient Temperature		0 to + 40°C (No freezing)			
Ambient Humidity		20 to 80% RH (Non-condensing)			
Vibration		24.5m/s ²			
Enclosure		Totally Enclosed, Forced-air cooling, IP44 (Except for shaft opening, when not equipped with oil seal.) IP20 for cooling fan			

(Note) The values in parentheses are for servo motors with holding brakes.

Torque-Speed Feature

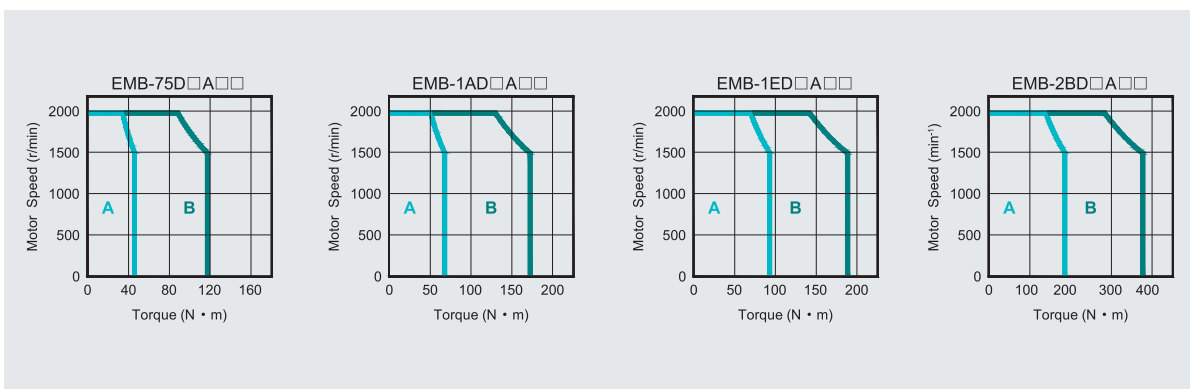

A: Continuous Working Area B: Repeatedly Working Area

Installation Diagrams

Servo Drive

ProNet-02A/04A ProNet-E-02A/04A

Unit: mm

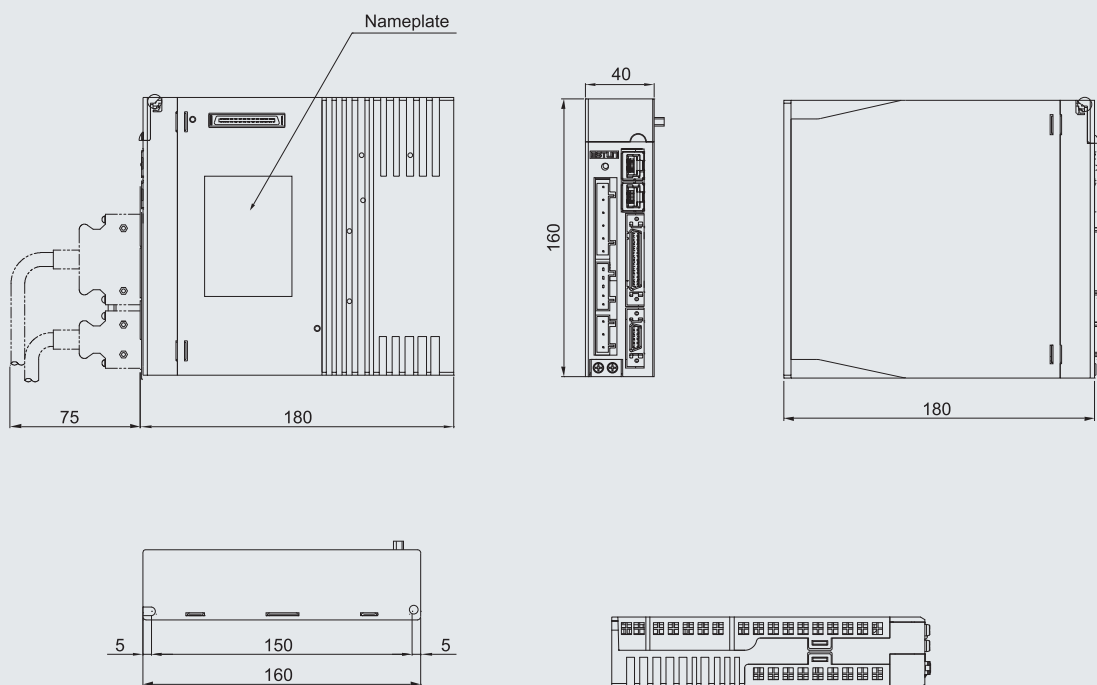

ProNet-08A/10A ProNET-E-08A/10A

Unit: mm

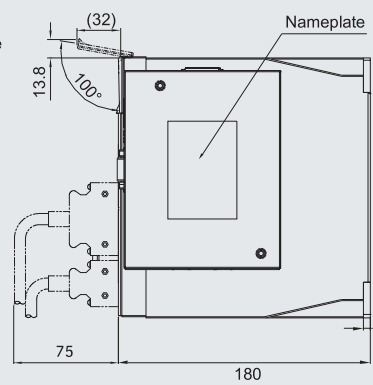
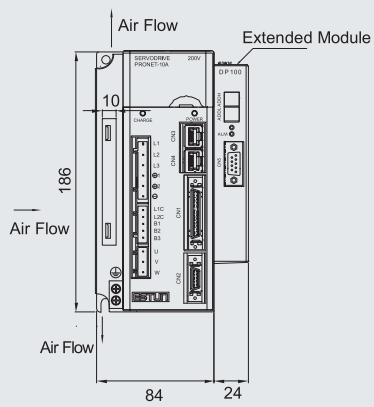
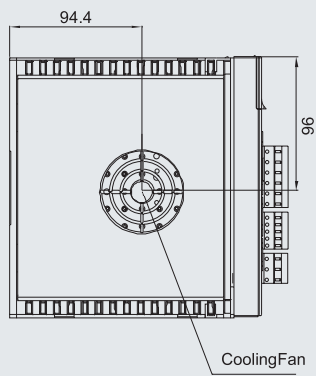

Mounting Hole Diagram

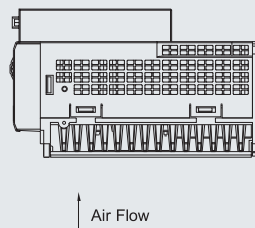
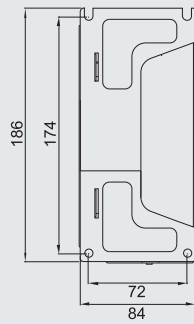

ProNet-10D/15A/15D ProNet-E-15A

Unit: mm

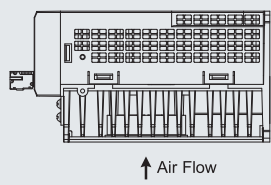
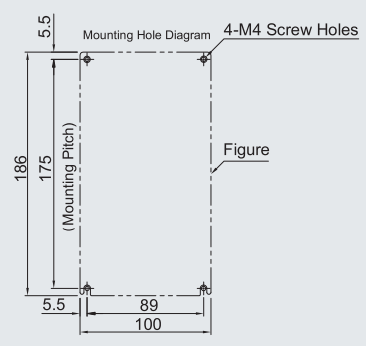
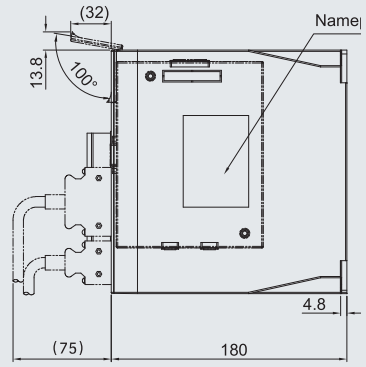
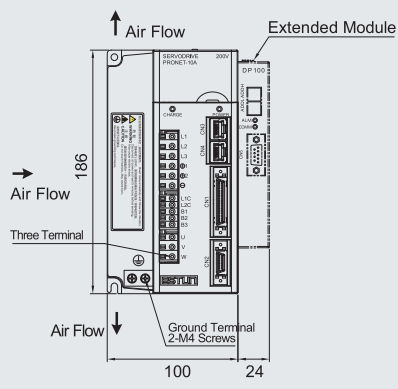
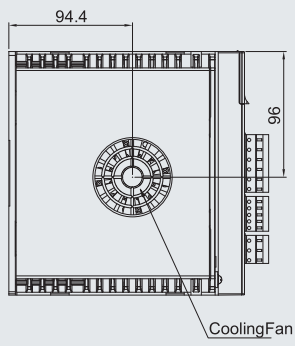

ProNet-20A/30A/50A ProNet-E-20A/30A/50A

Unit: mm

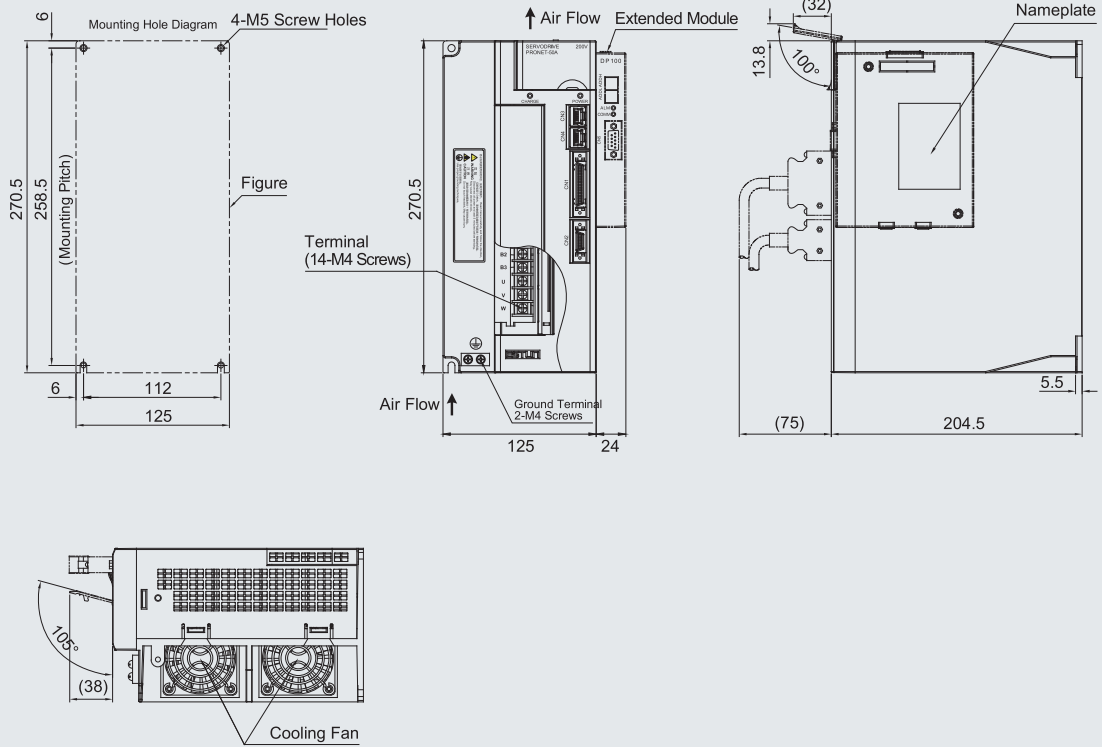

Servo Motor

EMJ Dimension

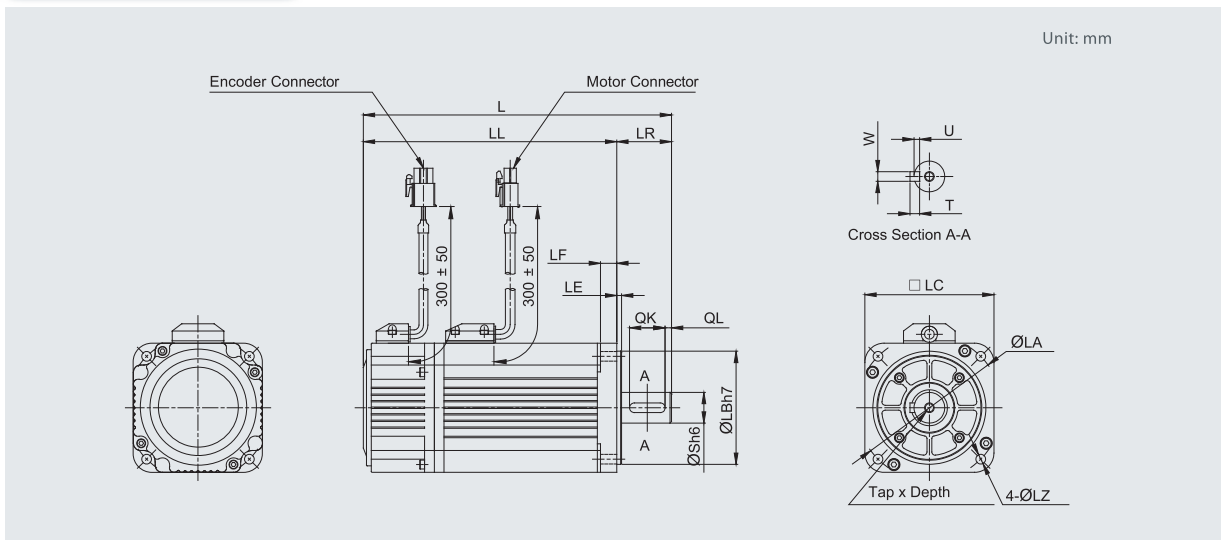

Model EMJ-	L	LL	Flange Side							S	Tap×Depth	Key				
			LR	LE	LF	LC	LA	LB	LZ			QK	QL	W	T	U
02ADA□□	141(181)	111(151)	30	3	6	60	70	50	5.5	14	M5×10L	16	4	5	5	3
02ARA□□																
02ASA□□																
02APA□□	141(181)	111(151)	30	3	6	60	70	50	5.5	14	M5×10L	16	4	5	5	3
04ADB□□	161(201)	131(171)	30	3	6	60	70	50	5.5	14	M5×10L	16	4	5	5	3
04ARB□□																
04ASB□□																
04APB□□	161(201)	131(171)	30	3	6	60	70	50	5.5	14	M5×10L	16	4	5	5	3
08ADB□□	173(216)	138(181)	35	3	9	80	90	70	6	19	M6×15L	22	4	6	6	3.5
08ARB□□																
08ASB□□																
08APB□□	173(216)	138(181)	35	3	9	80	90	70	6	19	M6×15L	22	4	6	6	3.5
10ADB□□	191(234)	156(199)	35	3	9	80	90	70	6	19	M6×15L	22	4	6	6	3.5
10ARB□□																
10ASB□□																
10APB□□	191(234)	156(199)	35	3	9	80	90	70	6	19	M6×15L	22	4	6	6	3.5

(Note) The dimension in parentheses are for servo motors with holding brakes.

Motor Connector Specification for EMJ-02/04/08/10□□

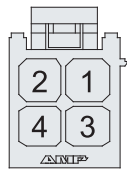

- Plug: 172167-1(AMP)
- Pin: 170360-1(AMP)

Pin No.	Signal	Color
1	U	Red
2	V	Blue
3	W	White
4	FG	Green/Yellow

Brake Connector Specification for EMJ-02/04/08/10□□

- Plug: 172165-1(AMP)
- Pin: 170360-1(AMP)



Pin No.	Signal	Color
1	B1	Blue
2	B2	White

Encoder Connector Specification for EMJ-02/04/08/10□□

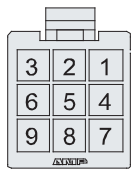

- Plug: 172169-1(AMP)
- Pin: 170359-3(AMP)

Pin No.	Signal	Color
1	A+	Blue
2	B+	Green
3	C+	Yellow
4	A-	Blue/Black
5	B-	Green/Black
6	C-	Yellow/Black
7	PG5V	Red
8	PG0V	Black
9	FG	Shield

Encoder Connector Specification for EMJ-02/04/08/10□□D/S/R

- Plug: CGRSD-7BFMA-SL8001

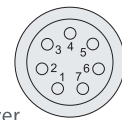

Pin No.	Signal	Color	Pin No.	Signal	Color
1	S+	Blue	1	SIN+	Yellow
2	S-	Blue/Black	2	SIN-	Blue
3	BAT+	Yellow	3	COS+	Red
4	BAT-	Blue/Black	4	COS-	Black
5	PG5V	Red	5	Ref+	Orange
6	PG0V	Black	6	Ref-	White
7	FG	Shield	7	FG	Shield

★ (Note) There are no BAT+, BAT- signal in incremental encoder

Motor Connector Specification for EMJ-02/04/08/10□
P-Waterproof(option)

Motor Connector Specification for EMJ-02/04/08/10□
D/S/R

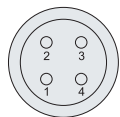

- Plug: CGRSB-4BFMA-SL8001

Pin No.	Signal	Color
1	U	Red
2	V	Blue
3	W	White
4	FG	Green/Yellow

Encoder Connector Specification for EMJ-02/04/08/10□
P-Waterproof(option)

Incremental Encoder(Wire-saving)

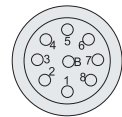

- Plug: CGRSD-9BFMA-SL8001

Pin No.	Signal	Color
1	A+	Blue
2	B-	Blue/Black
3	C+	Green
4	A-	Green/Black
5	B-	Yellow
6	C-	Yellow/Black
7	PG5V	Red
8	PG0V	Black
9	FG	Shield

Brake Connector Specification for EMJ-02/04/08/10□
P-Waterproof(option)

Brake Connector Specification for EMJ-02/04/08/10□
D/S/R

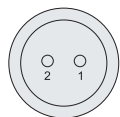

- Plug: CGRSB-2BFMA-SL8001

Pin No.	Signal	Color
1	B1	Blue
2	B2	White

EMG Dimension

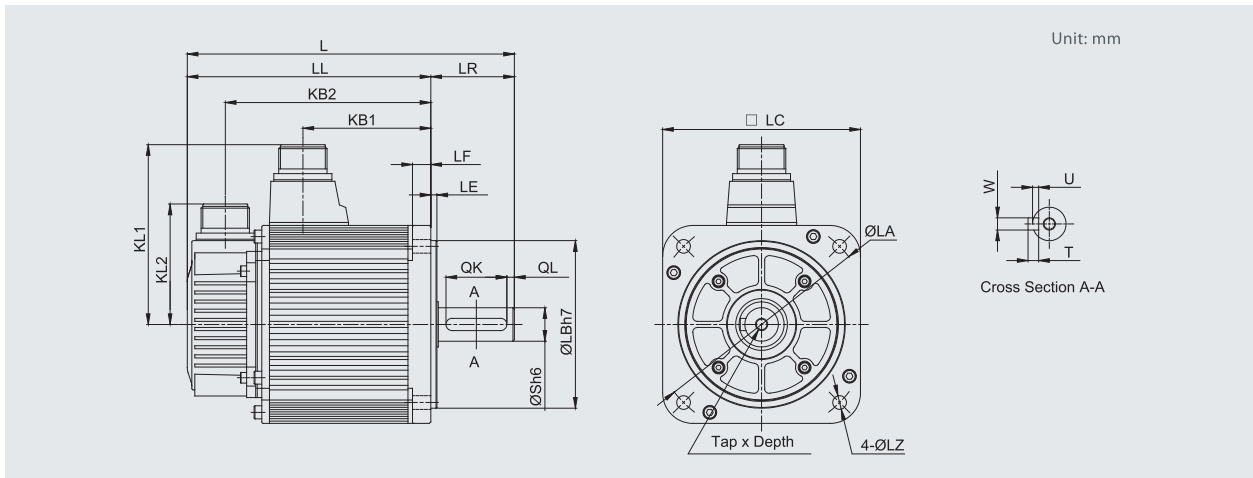

Model EMG-	L	LL	KB1	KB2	KL1	KL2	Flange Side							S	Tap×Depth	Key				
							LR	LE	LF	LC	LA	LB	LZ			QK	QL	W	T	U
10□□A□□	215(269.5)	160(214.5)	84	135(189.5)	118	79	55	4	12	130	145	110	9	22	M6×20L	40	5	8	7	4
15□□A□□	240(294.5)	185(239.5)	109	160(214.5)	118	79	55	4	12	130	145	110	9	22	M6×20L	40	5	8	7	4
20A□A□□	265(319.5)	210(264.5)	134	185(239.5)	118	79	55	4	12	130	145	110	9	22	M6×20L	40	5	8	7	4
30A□A□□	307(378)	228(299)	143	203(274)	140	79	79	3.2	18	180	200	114.3	13.5	35	M8×16L	55	6	10	8	5
50A□A□□	347(418)	268(339)	183	243(314)	140	79	79	3.2	18	180	200	114.3	13.5	35	M8×16L	55	6	10	8	5

(Note) The dimension in parentheses are for servo motors with holding brakes.

Motor Connector Specification

- Receptacle: MS3102A20-4P (LC=130)
MS3102A22-22P (LC=180)
- Plug: MS3108B20-4S (LC=130)
MS3108B22-22S (LC=180)
- Cable Clamp: MS3057-12A



Pin No.	Signal
A	U
B	V
C	W
D	FG

Brake Connector Specification

- Receptacle: MS3102A10SL-3P
- Plug: MS3106A10SL-3S
- Cable Clamp: MS3057-4A



Pin No.	Signal
A	B1
B	B2
C	-

Encoder Connector Specification

- Receptacle: MS3102A20-29P
- Plug: MS3108B20-29S
- Cable Clamp: MS3057-12A

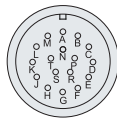

Incremental / Absolute Encoder

Pin No.	Signal	Color
K	S+	Blue
L	S-	Blue/Black
★T	BAT+	Brown
★S	BAT-	Brown/Black
H	PG5V	Red
G	PG0V	Black
J	FG	Shield

Resolver

Pin No.	Signal	Color
K	SIN+	Yellow
L	SIN-	Blue
T	COS+	Red
S	COS-	Black
H	R1	Red/White
G	R2	Yellow/White
J	FG	Shield

Incremental Encoder 2500P/R

Pin No.	Signal	Color
A	A+	Blue
B	A-	Blue/Black
C	B+	Green
D	B-	Green/Black
E	C+	Yellow
F	C-	Yellow/Black
G	PG0V	Black
H	FG5V	Red
J	FG	Shield

★ (Note) There are no BAT+, BAT- signal in incremental encoder.

EML Dimension

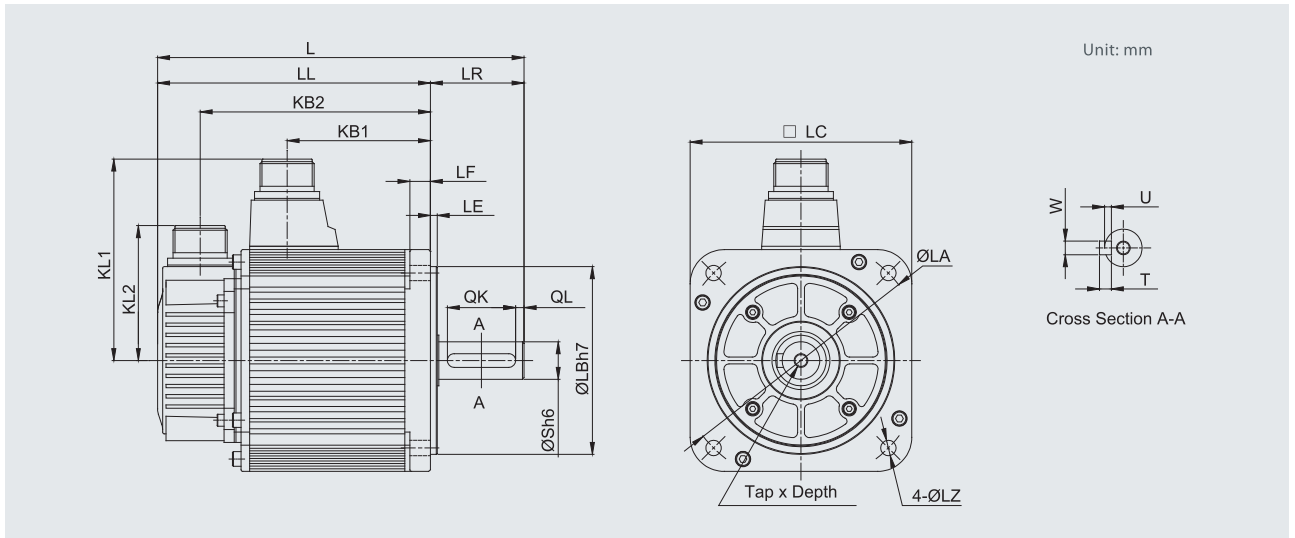

Model EML-	L	LL	KB1	KB2	KL1	KL2	Flange side							S	Tap×Depth	Key				
							LR	LE	LF	LC	LA	LB	LZ			QK	QL	W	T	U
10□□A□□	265(319.5)	210(264.5)	134	185(239.5)	118	79	55	4	12	130	145	110	9	22	M6×20L	40	5	8	7	4
20□□A□□	327(401)	248(322)	163	223(294)	140	79	79	3.2	18	180	200	114.3	13.5	35	M8×16L	55	6	10	8	5
30□□A□□	377(448)	298(369)	213	273(344)	140	79	79	3.2	18	180	200	114.3	13.5	35	M8×16L	55	6	10	8	5
40□□A□□	427(498)	348(419)	263	323(394)	140	79	79	3.2	18	180	200	114.3	13.5	35	M8×16L	55	6	10	8	5

(Note) The dimension in parentheses are for servo motors with holding brakes.

Motor Connector Specification

- Receptacle:
 - MS3102A20-4P (LC=130)
 - MS3102A22-22P (LC=180)
- Plug:
 - MS3108B20-4S (LC=130)
 - MS3108B22-22S (LC=180)
- Cable Clamp:
 - MS3057-12A



Pin No.	Signal
A	U
B	V
C	W
D	FG

Brake Connector Specification

- Receptacle:
 - MS3102A10SL-3P
- Plug:
 - MS3106A10SL-3S
- Cable Clamp:
 - MS3057-4A



Pin No.	Signal
A	B1
B	B2
C	-

Encoder Connector Specification

- Receptacle: MS3102A20-29P
- Plug: MS3108B20-29S
- Cable Clamp: MS3057-12A

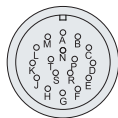

Incremental / Absolute Encoder

Pin No.	Signal	Color
K	S+	Blue
L	S-	Blue/Black
★T	BAT+	Brown
★S	BAT-	Brown/Black
H	PG5V	Red
G	PG0V	Black
J	FG	Shield

Resolver

Pin No.	Signal	Color
K	SIN+	Yellow
L	SIN-	Blue
T	COS+	Red
S	COS-	Black
H	R1	Red/White
G	R2	Yellow/White
J	FG	Shield

Incremental Encoder 2500P/R

Pin No.	Signal	Color
A	A+	Blue
B	A-	Blue/Black
C	B+	Green
D	B-	Green/Black
E	C+	Yellow
F	C-	Yellow/Black
G	PG0V	Black
H	PG5V	Red
J	FG	Shield

★ (Note) There are no BAT+, BAT- signal in incremental encoder.

EMB Dimension

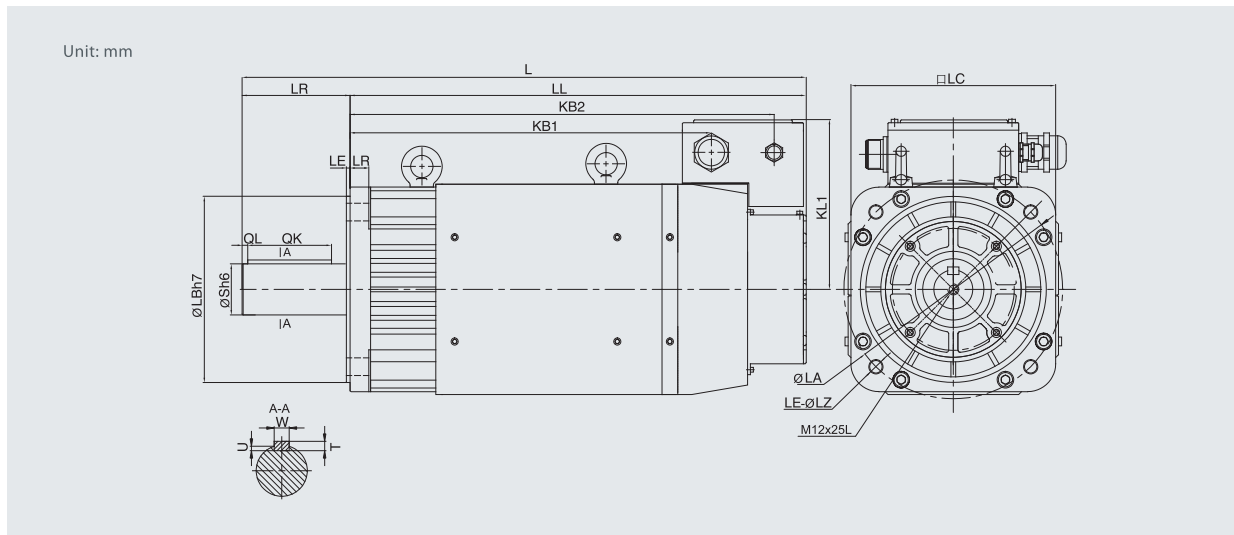

Model EMB-	L	LL	KB1	KB2	KL1	Flange Side						S	Tap x Depth	Key					
						LR	LE	LF	LC	LA	LB			LZ	QK	QL	W	T	U
75D□A□□	530 (625)	414 (509)	366 (461)	302 (397)	184	116	4	20	220	235	200	13.5	42	M16×32L	90	6	12	8	5
1AD□A□□	580 (675)	464 (559)	416 (511)	352 (447)	184	116	4	20	220	235	200	13.5	42	M16×32L	90	6	12	8	5
1ED□A□□	615 (710)	499 (594)	451 (546)	387 (482)	184	116	4	20	220	235	200	13.5	55	M20×40L	90	6	16	10	6
2BD□A□□	712 (807)	572 (667)	432 (527)	523 (618)	245 (340)	140	5	30	280	300	250	19	60	M12×25L	128	6	18	11	7

(Note) The dimension in parentheses are for servo motors with holding brakes.

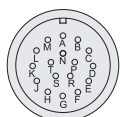

Encoder Connector Specification

- Receptacle: MS3102A20-29P
- Plug: MS3108B20-29S
- Cable Clamp: MS3057-12A

Brake Connector Specification

- Receptacle: MS3102A10SL-3P
- Plug: MS3106A10SL-3S
- Cable Clamp: MS3057-4A



Pin No.	Signal
A	B1
B	B2
C	-

Absolute Encoder

Pin No.	Signal	Color
K	S+	Blue
L	S-	Blue/Black
T	BAT+	Brown
S	BAT-	Brown/Black
H	PG5V	Red
G	PG0V	Black
J	FG	Shield

Resolver

Pin No.	Signal	Color
K	SIN+	Yellow
L	SIN-	Blue
T	COS+	Red
S	COS-	Black
H	R1	Red/White
G	R2	Yellow/White
J	FG	Shield
N	Sensor1	
R	Sensor2	

Connection

Typical Diagrams

Three-phase 200VAC (ProNet-02A to 04A)

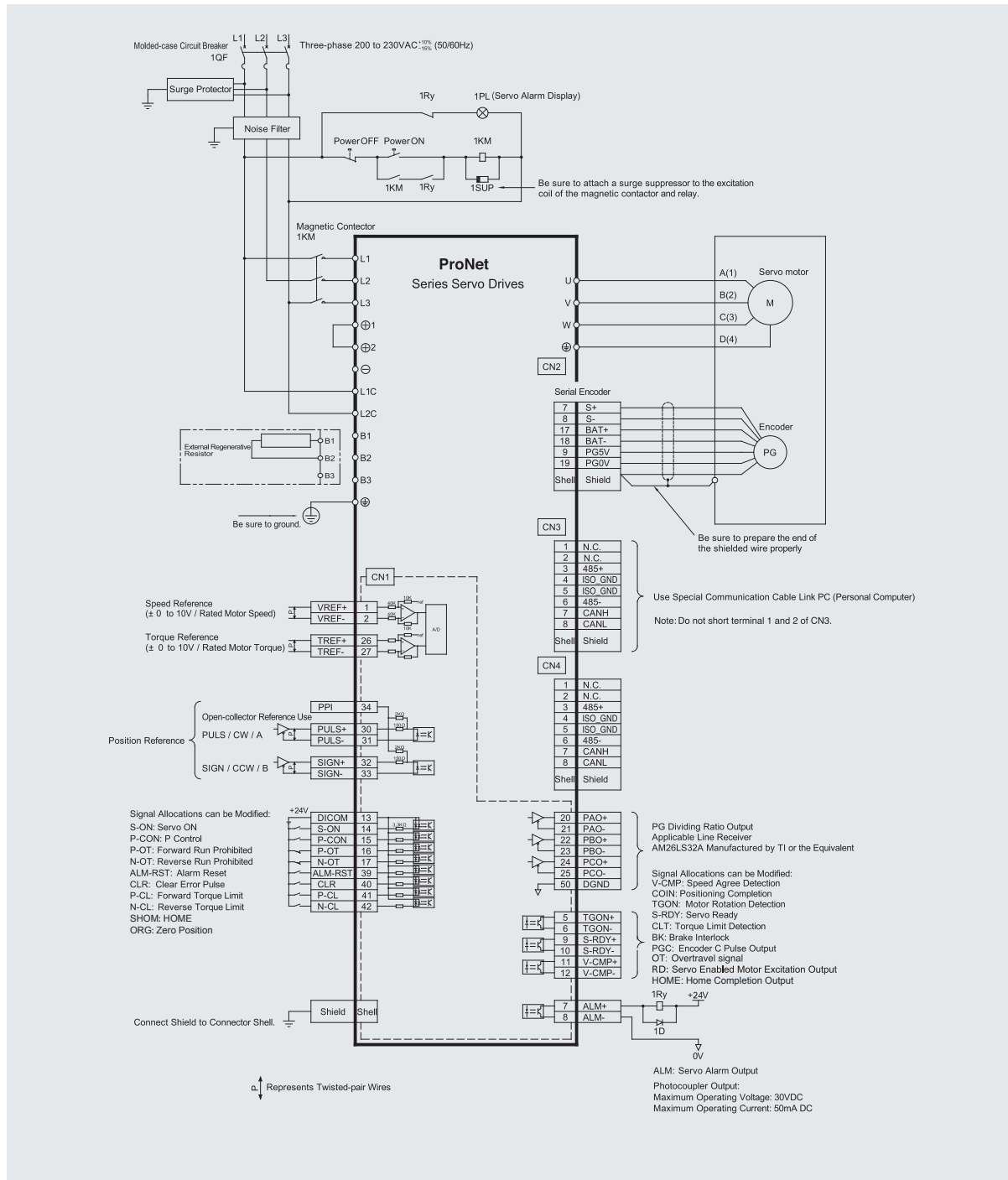

- Notes:
- ① The L1, L2, L3 and L1C, L2C terminals wiring method of ProNet 02/04 servo drives is different from other ProNet series servo drives. Please note the specific terminal definition while wiring.
 - ② External regenerative resistor for ProNet-02/04 is provided by customer, the model of ASQ60W50ΩKGO resistor is recommended.
 - ③ ProNet-02/04 servo drives are also available for single phase connection.
 - ④ Change Pn521 from "1" to "0" when using the external regenerative resistor in ProNet-02/04 servo drives.

Three-phase 200VAC (ProNet-08A to 50A)

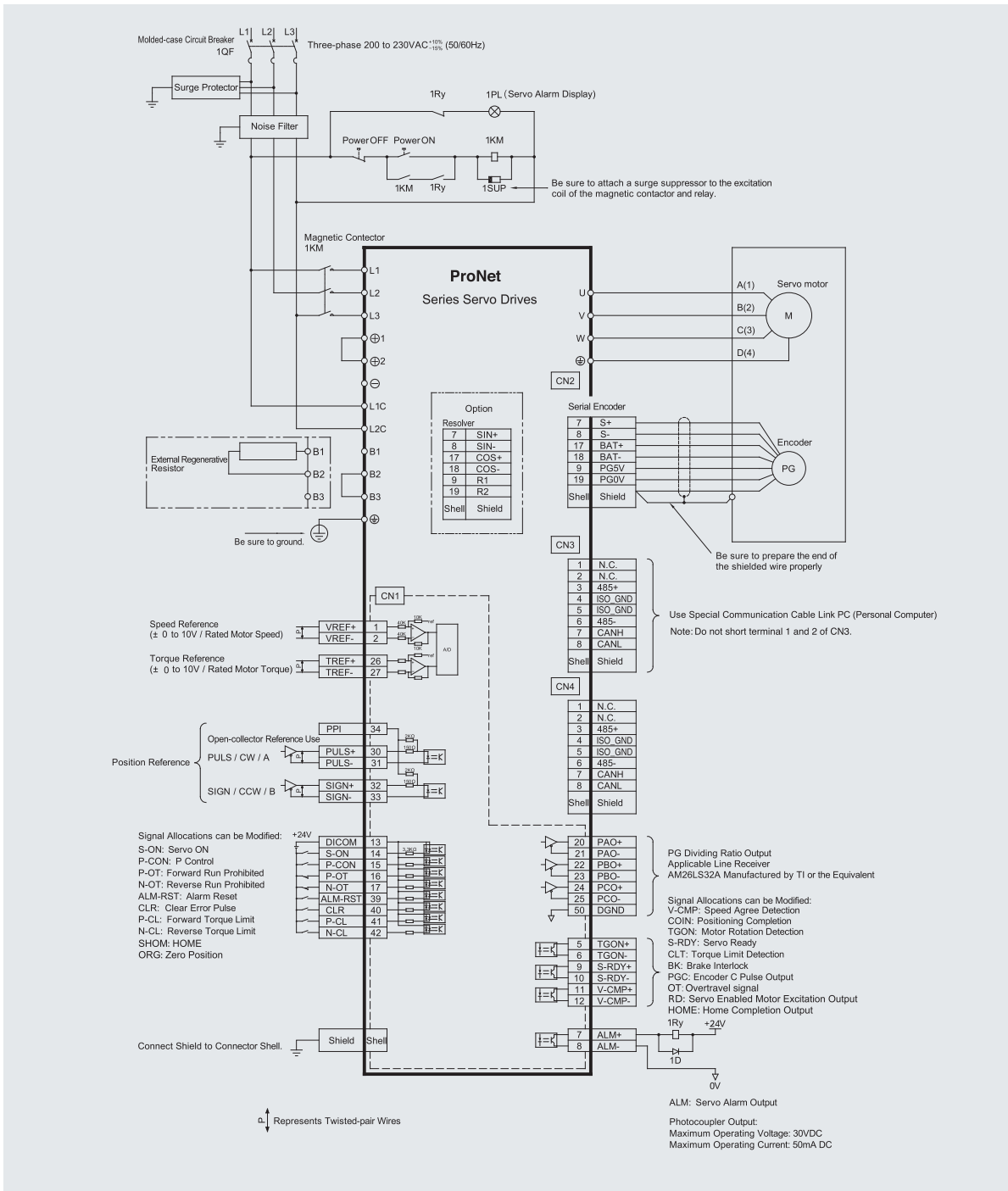

Three-phase 400VAC (ProNet-75D to 1ED)

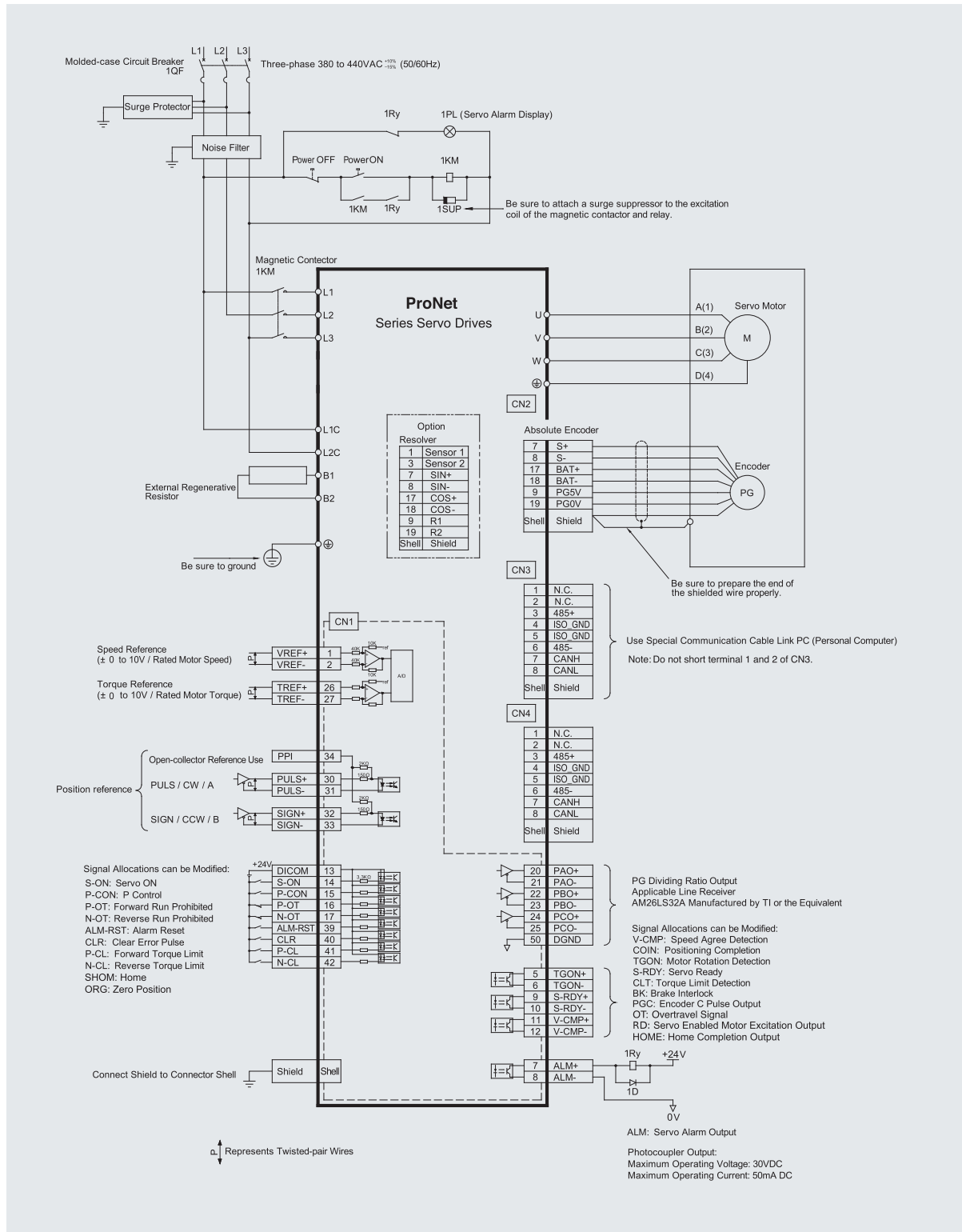

Notes: ① The resistor of 1500W and 20R is recommended for the external regenerative resistor of ProNet-75D.
 ② The resistor of 1500W and 15R is recommended for the external regenerative resistor of ProNet-1AD~1ED.

Three-phase 200VAC (ProNet-E-02A to 04A)

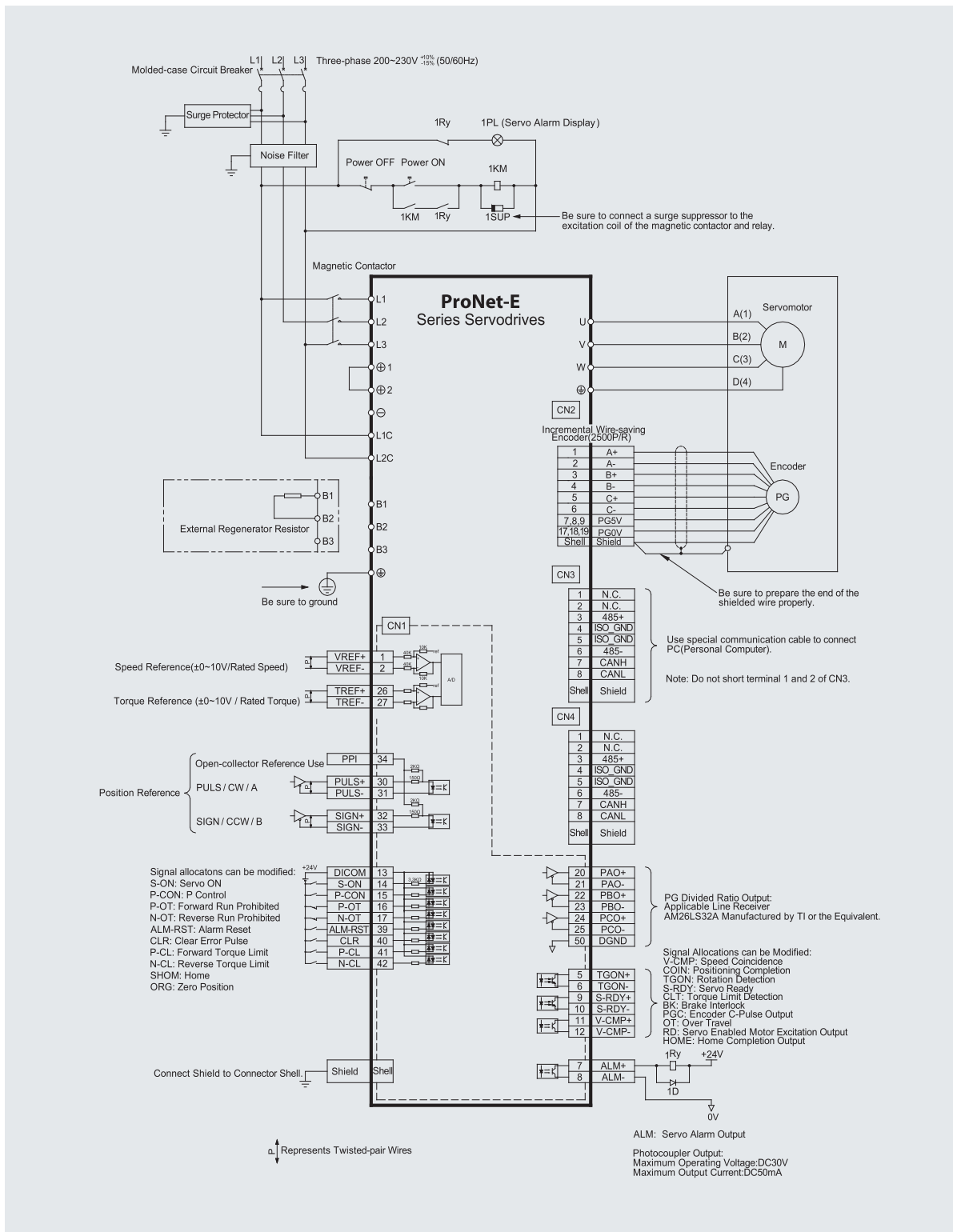





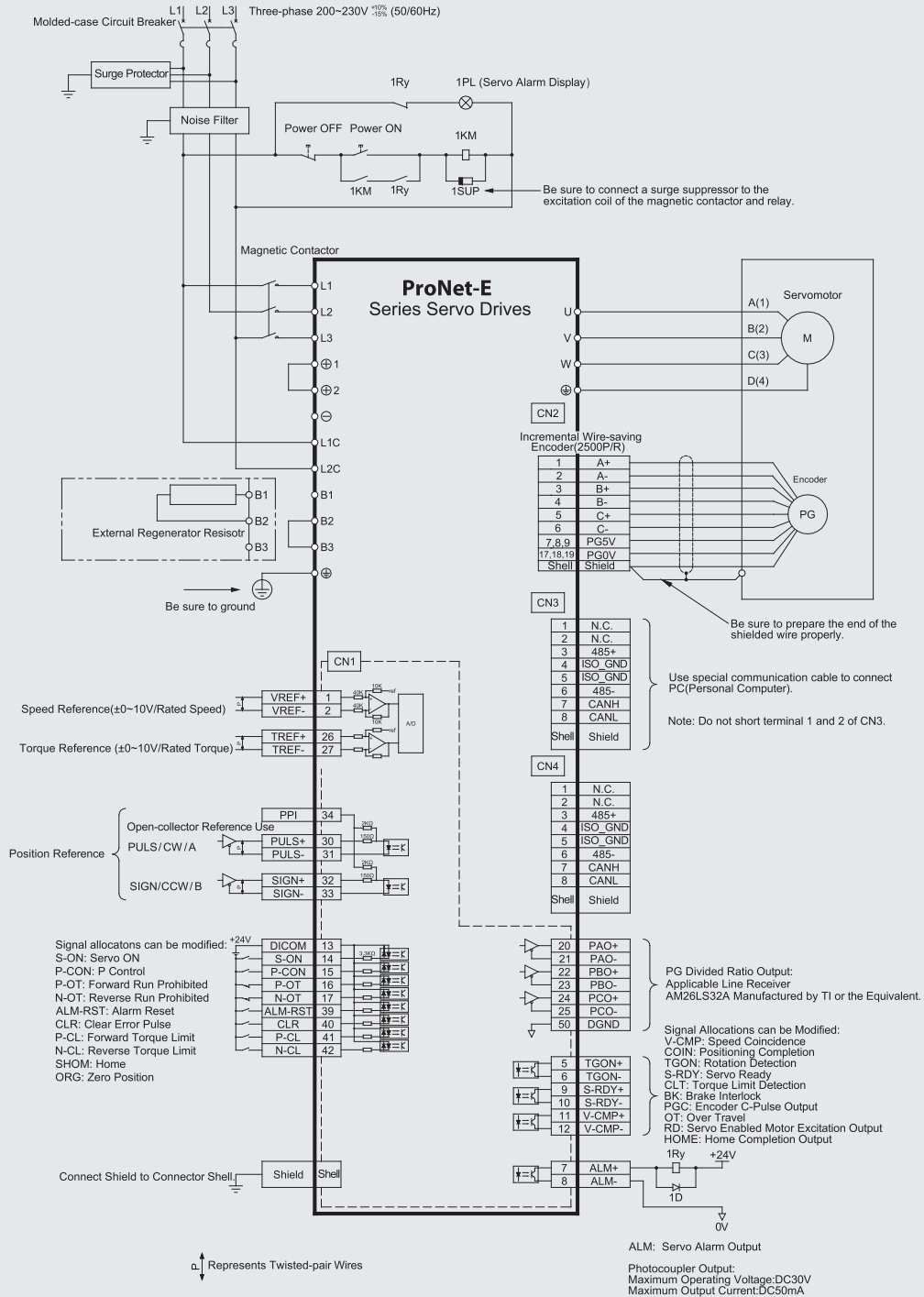

- Notes:
- ① The L1, L2, L3 and L1C, L2C terminals wiring method of ProNet-E 02/04 servo drives is different from other ProNet series servo drives. Please note the specific terminal definition while wiring.
 - ② External regenerative resistor for ProNet-E-02/04 is provided by customer, the model of ASQ60W50ΩKGO resistor is recommended.
 - ③ ProNet-E-02/04 servo drives are also available for single phase connection.
 - ④ Change Pn521 from "1" to "0" when using the external regenerative resistor in ProNet-E-02/04 servo drives.

Three-phase 200VAC (ProNet-E-08A to 50A)

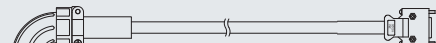
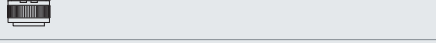

Accessories

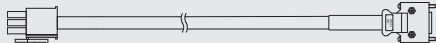
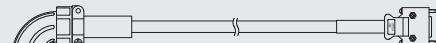
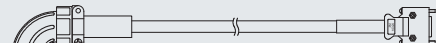
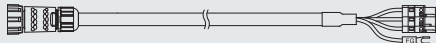
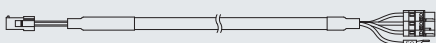
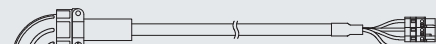
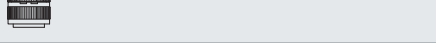
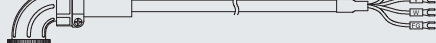
Specification Description

Name		Model	Specifications
Connector Kit	CN1	EC-CN1-50	
	CN2	EC-CN2-20	
Communication Cables	CN3	PSC-CC24-XX	
Serial Encoder Cables	EMJ	PSP-JE24-XX	
		PAP-JE24-XX	
	EMG EML EMB	PSP-GA24-XX	
		PAP-GA24-XX	
Wire-saving Incremental Encoder Cables	EMJ	BMP-JE24-XX	
		BMP-JB24-XX	
	EMG EML	BMP-GA24-XX	
Resolver Cables	EMG EML EMB	PRP-GA24-XX	
Power Cables	EMJ	PDM-JE18-XX	
		PDM-JB18-XX	
	EMG-10A EMG-15A EML-10A	PDM-GA16-XX	
	EMG-20A	PDM-GA14-XX	
	EML-20A	PDM-GD14-XX	
	EMG-30A / 50A EML-30A / 40A	PDM-GD12-XX	



ESTUN

Drive Your Success!

Mission — We are offering Accuracy & Efficiency!

Vision — Enjoy your life from Automation!

Values — Focus, Integrity, Growing together!

ESTUN AUTOMATION TECHNOLOGY CO., LTD.

ADD: 16 Shuige Road, Jiangning Development Zone,
Nanjing 211106, P.R. China

TEL: +86-25-58328505/8507

FAX: +86-25-58328504

Web: <http://www.estun.cn>

E-mail: export@estun.com

Version: ProNet-1208A

