



# Stepper Motor Driver CW2283

## 1. Introduction

### Descriptions

CW2283 is subdivided and high-performance stepper motor drive using constant angle and constant torque, which is designed for 130BYG、110BYG and other 8A following two-phase, four-phase hybrid stepping motor. The driver uses the circuit which is similar to the principle of servo control with the features of smooth running, low noise, low vibration, low temperature rise of the motor. It has 16 kinds of micro-step, and the micro-step can be set from full step to 51200steps/rev. The working current can be set from 2.0A to 8.3A, and the output current has 16 stalls, the current resolution is about 0.5A; with automatic semi-flow, self-test, overvoltage, under-voltage and over-current protection. This driver is AC power, Voltage does not exceed 240VAC not less than 120VAC.

### Features

- High-performance, low price
- micro-step
- Automatic idle-current reduction
- Optical isolating signal I/O
- Max response frequency up to 200Kpps
- Low temperature rise, smooth motion
- Online adaptive PID technology

### Applications

Suitable for a variety of large-scale automation equipments and instruments. For example: labeling machine, cutting machine, packaging machine, plotter, engraving machine, CNC machine tools and so on. It always performs well when applied for equipment which requires for low-vibration, low-noise, high-precision and high-velocity.



## Electrical Specifications

Parameter	Min	Typical	Max	Unit
Input Voltage(AC)	150	-	220	VAC
Output current	0	-	8.3	A
Pulse Signal Frequency	0	-	200	KHZ
Logic Signal Current	7	10	16	MA

## 2 . parameter setting

### Current setting

Dial switch: ON=0;OFF=1

Phase current	SW1	SW2	SW3	SW4
2.0	1	1	1	1
2.4	0	1	1	1
2.8	1	0	1	1
3.2	0	0	1	1
3.6	1	1	0	1
4.2	0	1	0	1
4.8	1	0	0	1
5.2	0	0	0	1
5.6	1	1	1	0
6.0	0	1	1	0
6.4	1	0	1	0
6.8	0	0	1	0
7.2	1	1	0	0
7.6	0	1	0	0
8.0	1	0	0	0
8.3	0	0	0	0



## Standstill Current Setting

Half current is default .

## Micro-step Setting

Dial switch: ON=0;OFF=1

Subdivision	SW7	SW8	SW9	SW10
400	0	0	0	0
800	1	0	0	0
1600	0	1	0	0
3200	1	1	0	0
6400	0	0	1	0
12800	1	0	1	0
25600	0	1	1	0
51200	1	1	1	0
1000	0	0	0	1
2000	1	0	0	1
4000	0	1	0	1
8000	1	1	0	1
10000	0	0	1	1
20000	1	0	1	1
25000	0	1	1	1
50000	1	1	1	1

## 3. Connectors and Pin Assignment

### Control signal Connector

signal	function	
FAULT	Common anode input positive terminal	Common anode input positive terminal(+5V)
PUL	Pulse signal terminal	Pulse signal control the motor to run motor run 1 step after each pulse.



DIR	Direction signal terminal	Direction control signal control the motor running direction.
ENA	Enable signal terminal	motor is offline when Enable signal is active, no internal current.

### Power and Motor Connector

AC	Power supply, 150~220VAC
AC	
A+	Motor phase A
A-	
B+	Motor phase B
B-	

### Control Signal Connector Interface

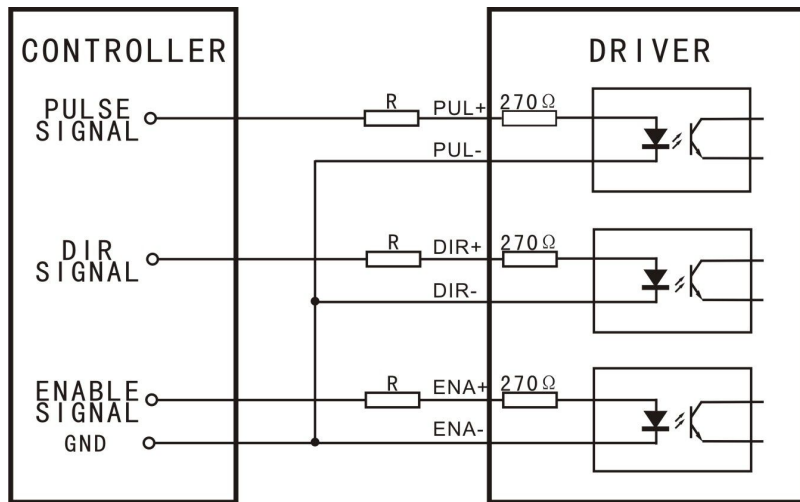

Figure1: Common-Cathode

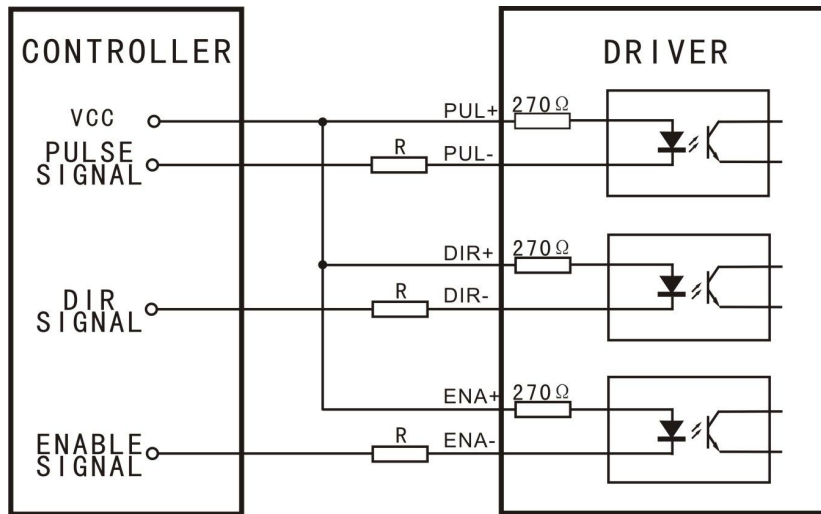

Figure2: Common-Anode

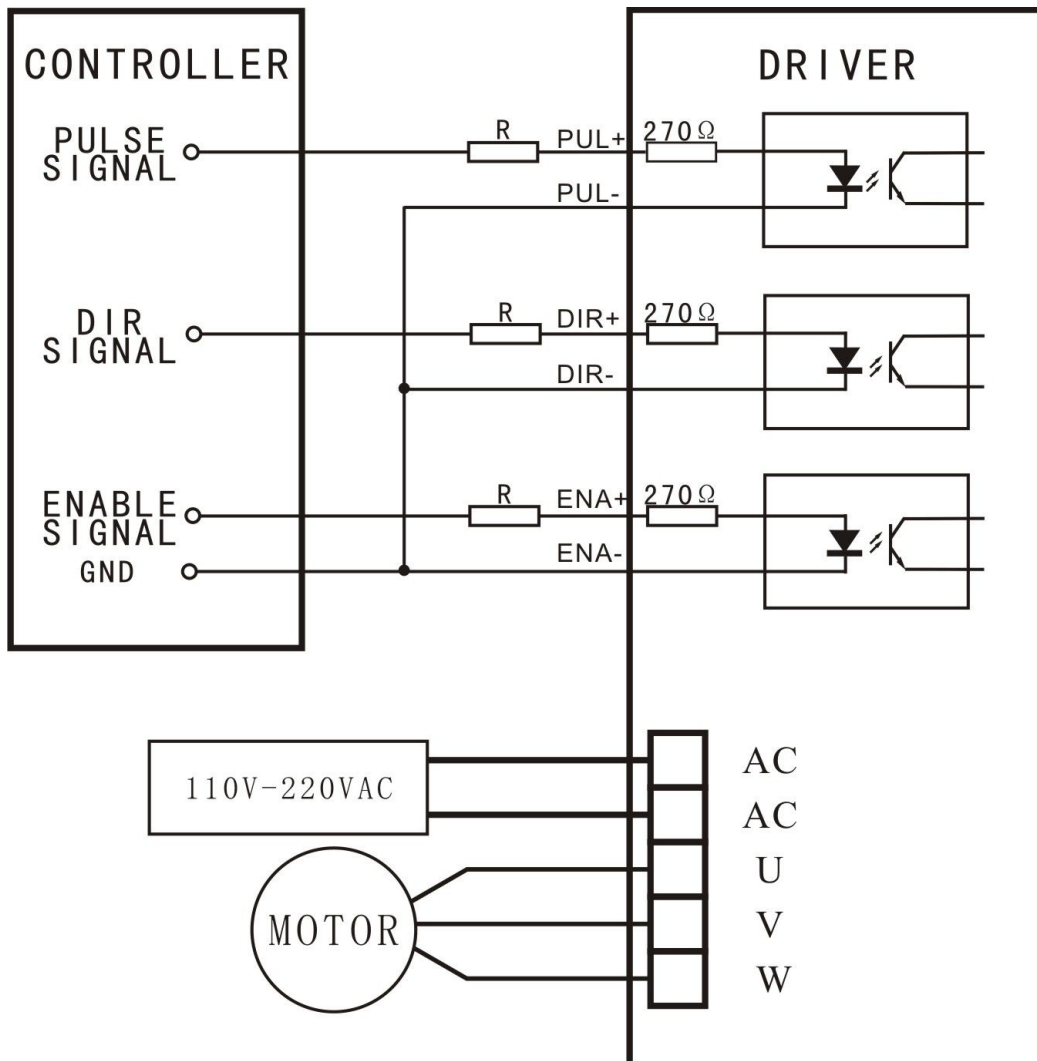

Figure 3: Typical connection



VCC	R
5V	不加
12V	1K $\Omega$
24V	2K $\Omega$

Table1

## 4. Problems and Solutions

Phenomenon	Possible Cause	Solutions
<b>Fault indicator brightens red for a long time (over-current)</b>	Electrical wire shorted	Check the motor lines and eliminate short circuit
	Motor failure	Replace motor
	Other reasons	Check back



### 5. Mechanical Specifications (unit: mm(inch), 1 inch = 25.4mm)

