

HIGH FREQUENCY SPINDLE MOTORS

Fimec spindle motors are designed to produce high torque and high speeds in compact dimensions. This makes the motor ideal for machining wood, plastics, aluminium, marble and glass for use in jobs ranging from routing, drilling and sawing to cutting, boring and grinding. Cooling is provided by a proprietary fan which rotates at spindle speed or, on request, by an electric fan independent from motor speed (separate electric fan warrants cooling at speeds lower than 7000rpm and for noiseless workings at the highest speeds).

These motors also include a labyrinth sealing arrangement to virtually eliminate any possibility of foreign particles damaging the bearings.

Fimec spindle motors are available with keyed or collet shaft.

Motors with keyed and threaded shaft (type L) mount a single deep groove spindle bearing at both ends of the housing. In this case, the motor can accept light plunge cutting, inducing axial loads but it is more suitable for those applications mainly involving radial loads.

Motors with collet shaft (type P) mount a double angular contact thrust bearing at the work end, with a single deep groove support bearing at the opposite end. They are designed for those applications requiring heavy plunge cutting, inducing high axial loads, on a regular basis.



ÉLECTROBROCHES (Moteurs à hautes vitesses)

Les électrobroches Fimec sont moteurs compacts pour hautes vitesses (jusqu'à 24000 tour-minute). Ces moteurs doivent être connectés à un variateur de fréquence pour leur fonctionnement car il faut obtenir des hautes fréquences pour avoir des hautes nombres de tours. Généralement nos électrobroches sont utilisés dans les machines pour le bois, plastique, aluminium, marbre et verre pour des travaux de perçage, gravure, façonnage, etc. Les roulements sont étanches, ils ne nécessitent pas d'entretien et sont protégés avec des labyrinthes extérieurs. Les électrobroches Fimec sont disponibles avec un arbre pour fixation à pince (série P) ou avec un arbre lisse (série L). Les moteurs du série P sont disponibles soit avec ventilateur calé sur l'arbre soit avec électro ventilateur alimenté séparément du moteur. Pour les électrobroches avec ventilateur calé on conseille de ne les utiliser pas à vitesses inférieure à 6000/7000 tours pour ne compromettre pas la ventilation du moteur. Par contre les moteurs avec électro ventilateur peuvent être utilisés à vitesses inférieures (car la ventilation du moteur reste constante) et assurent un silence plus grand à 24000 tours.

Les moteurs du série P sont fabriqués en version HM, c'est-à-dire que ils sont indiqués pour des gros travaux comme, par exemple, des perçages, ou on demande une charge axiale très élevée.

Par contre les moteurs du série L sont fournis seulement pour des travaux plus légers (version HT) qui impliquent une charge principalement radiale sur l'arbre et modeste charge axiale.



ELECTROMANDRILES (Motores para altas velocidades)

Los electromandriles Fimec son motores compactos para uso a altas velocidades (hasta 24000 vueltas). Su funcionamiento se lleva a cabo mediante la conexión con un inversor ya que son necesarias otras frecuencias para obtener un elevado número de vueltas. Normalmente nuestros electromandriles se usan en máquinas para trabajar la madera, plástico, aluminio, mármol y cristal para trabajos de perforación, incisión, perfilado, etc. Los cojinetes vienen prelubricados y con estanqueidad, no necesitan mantenimiento y están protegidos de los choques externos. Los electromandriles están disponibles con eje de enganche de pinza (serie P) o con eje de enganche de lengüeta (serie L). Los motores con eje de enganche de pinza están disponibles ya sea con ventilador ajustada en el eje, se recomienda no usar los motores a velocidades inferiores a 6000/7000 vueltas de modo que se pueda asegurar una correcta y suficiente ventilación del motor. Los motores con electroventiladores, garantizan una menor emisión de ruidos y altas velocidades (sobre todo con 24000 vueltas) y ofrecen la posibilidad de poder usar el motor también con velocidades más bajas de las normales, permitidas con el ventilador ajustado (7000 vueltas) porque el enfriamiento general del motor no resulta penalizado.

Los motores con el eje de enganche de pinza de tipo P están fabricados para la versión HM, y son especiales para los trabajos pesados como, por ejemplo, los de perforado, donde se necesita una elevada carga axial. Los motores con eje de acoplamiento de lengüeta (L) son suministrados sólo con la versión HT para trabajos más ligeros, con cargas prevalentemente sobre el eje radial y con una moderada carga axial.



FRÄSMOTOREN (HIGH-SPEED MOTOREN)

Die Familie der Fräsmotoren wurde entwickelt mit der Vorgabe, leistungsdichte Motoren einzusetzen um kompakte Einheiten zu erhalten, wie sie vor allem für Werkzeugmaschine der Bereiche Holz, Kunststoff und Aluminium gesucht werden. Die Konstruktion basiert auf einem Grundkörper aus stranggepressten Profilen, die mit innenliegenden Kühlrippen für einen optimalen Luftstrom zur Kühlung versehen sind. Die Kugellager sind dauerfettgeschmiert und gedeckelt, benötigen damit keine Wartung, und werden durch Labyrinthdichtungen geschützt. Die Fräsmotoren mit rechteckigem Gehäuse sind speziell ausgelegt für die verschiedensten Anwendungen im Bereich Fräsen, Kantenbearbeitung und Bohren. Die Modelle mit Spannzangenaufnahme sind verfügbar mit feststehendem Lüfterrad oder externem Elektrolüfter. Es gibt ein breites Band an verfügbaren Motoren, zwischen 0,35kW und 13,5kW mit Drehzahlen bis 24.000 min⁻¹, die es den Kunden ermöglicht, jegliche Anwendung abzudecken, sowohl mit axialer wie auch mit radialer Belastung. Fräsmotoren sind Produkte die alle Industrienormen erfüllen. Sie bieten dem Kunden hohe Leistung im Dauerlastbetrieb sowie im Teillastbetrieb.

HIGH SPEED SPINDLE MOTORS WITH COLLET SHAFT (Type P)



	<i>Motor</i>	<i>Shaft</i>	<i>Voltage</i>	<i>Rotation</i>	<i>Speed</i>	<i>Kw S1</i>	<i>Kw S6</i>	<i>Poles</i>	<i>Fixing</i>	<i>Connection</i>	<i>Cable exit</i>
55	HM55a-090P	ER20	380V	CCW	12/12000	0,65	0,85	2	Bottom	Connector	Front
	HM55d-090P	ER20	380V	CCW	18/24000	1,00	1,30	2	Bottom(and lateral)	Connector	Front
	Hm55e-070P*	ER20	380V	CCW	18/30000	1,00	1,30	2	Bottom	Connector	Front
	HM55a-090P	ER20	220V	CCW	12/12000	0,65	0,85	2	Bottom	Connector	Front
	HM55d-090P	ER20	220V	CCW	18/24000	1,00	1,30	2	Bottom	Connector	Front
	Hm55e-090P*	ER20	220/380V	CCW	18/26000	1,00	1,30	2	Bottom	T. box	Front
	Hm55e-070P*	ER20	220	CCW	18/30000	1,00	1,30	2	Bottom	Connector	Front

*Liquid cooling

73-060	HM73a-060P	ER25	380V	CCW	12/12000	1,00	1,30	2	Bottom	Connector	Rear
	HM73b-060P	ER25	380V	CCW	18/18000	1,50	1,80	2	Bottom	Connector	Rear
	HM73c-060P	ER25	380V	CCW	18/18000	1,50	1,80	2	Bottom and lateral right	Connector	Rear
	HM73d-060P	ER25	380V	CCW	18/24000	1,50	1,80	2	Bottom	Connector	Rear
	HM73a-060P	ER25	220V	CCW	12/12000	1,00	1,30	2	Bottom	Connector	Rear
	HM73b-060P	ER25	220V	CCW	18/18000	1,50	1,80	2	Bottom	Connector	Rear
	HM73d-060P	ER25	220V	CCW	18/24000	1,50	1,80	2	Bottom	Connector	Rear

73-120	Hm73a-120P	ER25	380V	CCW	12/12000	2,00	2,40	2	Bottom	Connector	Rear
	Hm73b-120P	ER25	380V	CCW	18/18000	3,00	3,60	2	Bottom	Connector	Rear
	Hm73c-120P	ER25	380v	CW	18/18000	3,00	3,60	2	Bottom	Connector	Rear
	Hm73d-120P	ER25	380v	CCW	18/24000	3,00	3,60	2	Bottom	Connector	Rear
	Hm73e-120P	ER25	380v	CCW	18/24000	3,00	3,60	2	Bottom & lateral	Connector	Rear
	Hm73a-120P	ER25	220V	CCW	12/12000	2,00	2,40	2	Bottom	Connector	Rear
	Hm73b-120P	ER25	220V	CCW	18/18000	3,00	3,60	2	Bottom	Connector	Rear
	Hm73c-120P	ER25	220v	CW	18/18000	3,00	3,60	2	Bottom	Connector	Rear
	Hm73d-120P	ER25	220v	CCW	18/24000	3,00	3,60	2	Bottom	Connector	Rear

90-100	Hm90a-100P	ER32	380v	CCW	12/12000	3,50	4,20	2	Bottom	Connector	Front
	Hm90b-100P	ER32	380v	CCW	18/18000	4,50	5,40	2	Bottom	Connector	Front
	Hm90c-100P	ER32	380V	CCW	18/18000	4,50	5,40	2	Bottom & lateral	Connector	Rear
	Hm90d-100P	ER32	380V	CCW	18/24000	4,50	5,40	2	Bottom	Connector	Front

Hm90a-100P	ER32	220vv	CCW	12/12000	3,50	4,20	2	Bottom	T. box	Front
Hm90b-100P	ER32	220v	CCW	18/18000	4,50	5,40	2	Bottom	T. box	Front
Hm90d-100P	ER32	220V	CCW	18/24000	4,50	5,40	2	Bottom	T. box	Front

90-140	Hm90a-140P	ER32	380V	CCW	12/12000	5,00	6,00	2	Bottom	Connector	Front
	Hm90b-140P	ER32	380V	CCW	18/18000	6,00	7,20	2	Bottom	Connector	Front
	Hm90d-140P	ER32	380V	CCW	18/24000	6,00	7,20	2	Bottom	Connector	Front
	Hm90a-140P	ER32	220V	CCW	12/12000	5,00	6,00	2	Bottom	T. box	Front
	Hm90b-140P	ER32	220V	CCW	18/18000	6,00	7,20	2	Bottom	T. box	Front
	Hm90d-140P	ER32	220V	CCW	18/24000	6,00	7,20	2	Bottom	T. box	Front
	Hm90e-140P	ER32	380/220V	CCW	14/18000	8,50		4	Bottom	T. box	Front

120	Hm120-170P	ER40	380V	CCW	12/18000	13,50	16,20	4	Bottom	T. box	Front
	Hm120b-170P	ER40	380V	CCW	6/6000	8,10	9,70	4	Bottom	Connector	Front
	Hm120c-170P	ER40	380V	CCW	12/18000	13,50	16,20	4	Lateral right	Connector	Front

Indicative Dimensions

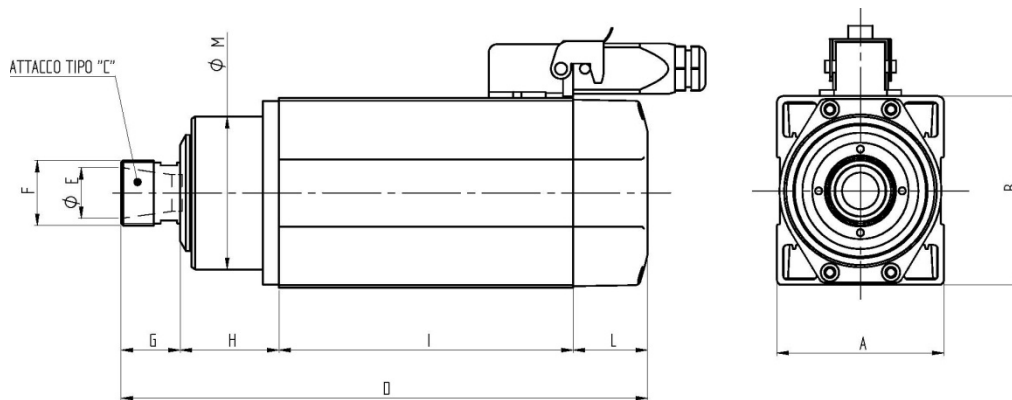

	A	B	C	D	Y	F	G	H	I	L	M
55-090	70	72	ER20	251	20	M25x1,5	27,5	41,5	153	29	56
73-060	82	93	ER25	258,5	25	M32x1,5	29	48,5	144,5	36,5	75
73-120	82	93	ER25	328,5	25	M32x1,5	29	48,5	214,5	36,5	75
90-100	103	120	ER32	310,5	32	M40x1,5	35	48,5	181	46	85
90-140	103	120	ER32	350,5	32	M40x1,5	35	48,5	221	46	85
120-170	177	145	ER40	454,5	40	M50x1,5	38	61,5	300	55	120

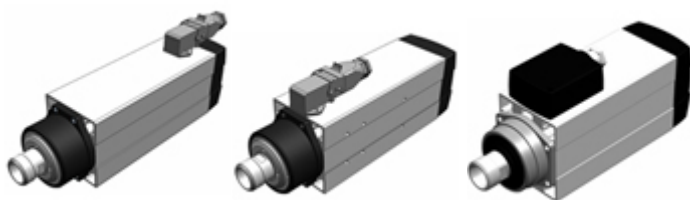

Example of spindle motors with front and rear connector and with terminal box.

High Speed Spindle motor with collet shaft and electric fan

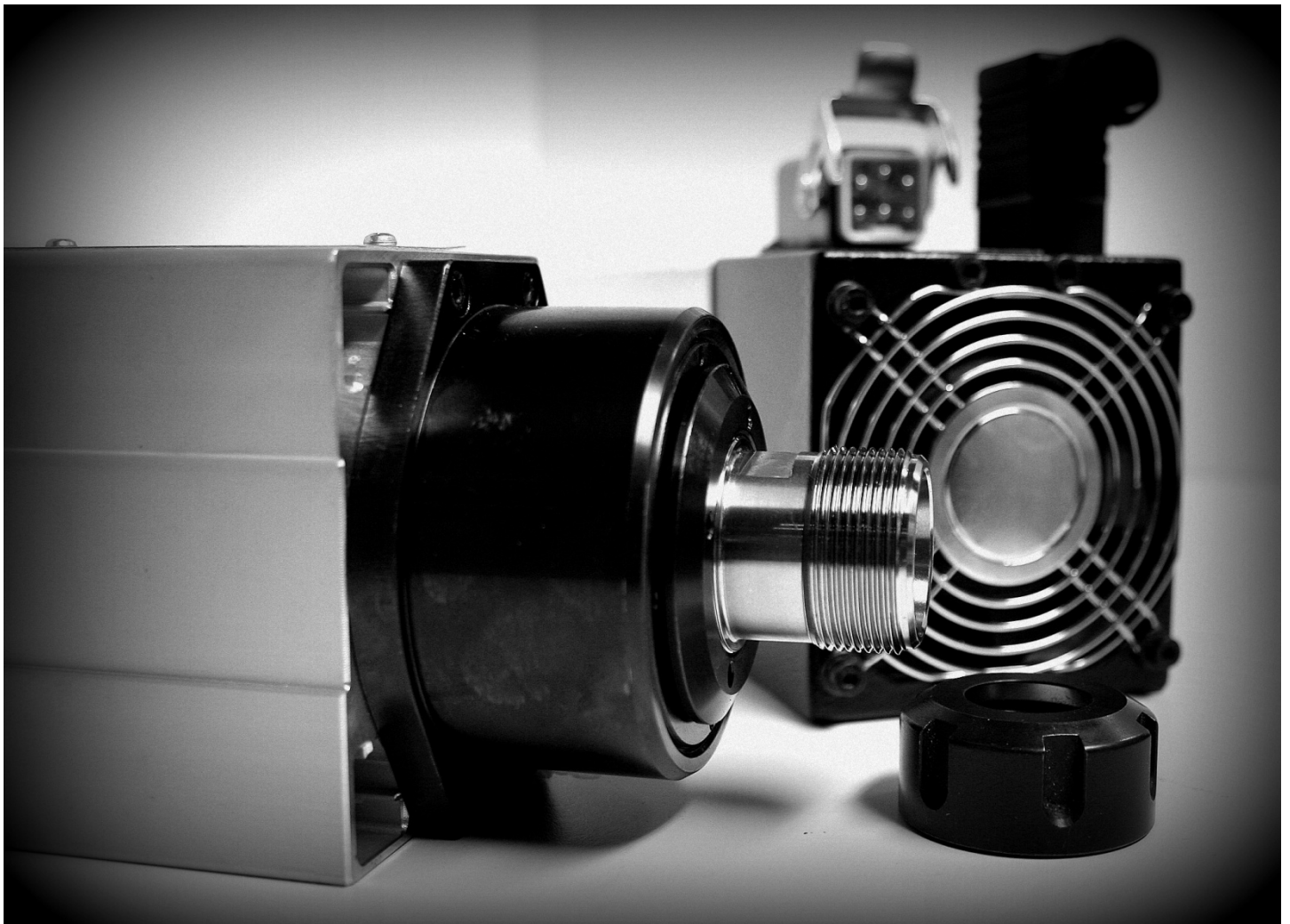

	Motor	Shaft	Voltage	Rotation	Speed rpm	Kw S1	Kw S6	Fixing	Connection	Cable exit
73-060	Hm73b-060P-EL	ER25	380V	CCW	18/18000	1.1	1.38	Bottom	Connector	Rear
	Hm73d-060P-EL	ER25	380V	CCW	18/24000	1.1	1.38	Bottom	Connector	Rear
	Hm73b-060P-EL	ER25	220V	CCW	18/18000	1.1	1.38	Bottom	Connector	Rear
	Hm73d-060P-EL	ER25	220V	CCW	18/24000	1.1	1.38	Bottom	Connector	Rear

73-120	HM73b-120P-EL	ER25	380V	CCW	18/18000	2.10	2.8	Bottom	Connector	Rear
	Hm73d-120P-EL	ER25	380V	CCW	18/24000	2.10	2.8	Bottom	Connector	Rear
	Hm73b-120P-EL	ER25	380V	CCW	18/18000	2.10	2.8	Bottom	Connector	Rear
	Hm73d-120P-EL	ER25	380V	CCW	18/24000	2.10	2.8	Bottom	Connector	Rear

90-100	HM90b-100P-EL	ER32	380V	CCW	18/18000	2,50	3.2	Bottom	Connector	Front
	HM90d-100P-EL	ER32	380V	CCW	18/24000	2.50	3.2	Bottom	Connector	Front
	HM90b-100P-EL	ER32	220V	CCW	18/18000	2,50	3.2	Bottom	T. Box	Front
	HM90d-100P-EL	ER32	220V	CCW	18/24000	2.50	3.2	Bottom	T.Box	Front

90-140	HM90b-140P-EL	ER32	380V	CCW	18/18000	3.9	5.1	Bottom	Connector	Front
	HM90d-140P-EL	ER32	380V	CCW	18/24000	3.9	5.1	Bottom	Connector	Front
	HM90b-140P-EL	ER32	220V	CCW	18/18000	3.9	5.1	Bottom	T.box	Front
	HM90d-140P-EL	ER32	220V	CCW	18/24000	3.9	5.1	Bottom	T. box	Front
	HM90e-140P-EL	ER32	220/380V	CCW	14/18000	7		Bottom	T.box	Rear
	HM90e-140P-EL	ER32	220/380V	CCW	14/18000	7		Bottom	T. box	Rear

120	HM120-170P-EL	ER40	380V	CCW	12/12000	13.5		Lateral right	Connector	Front
-----	---------------	------	------	-----	----------	------	--	---------------	-----------	-------

DIMENSIONI INDICATIVE

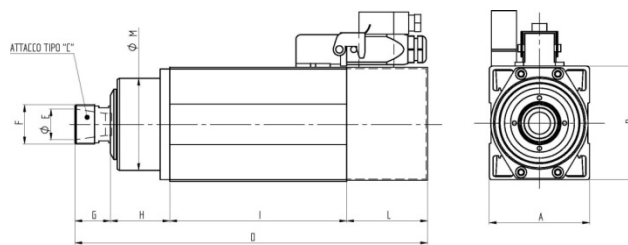

	A	B	C	D	Y	F	G	H	I	L	M
73-060	82	93	ER25	288	25	M32x1,5	29	48,5	144,5	66	75
73-120	82	93	ER25	358	25	M32x1,5	29	48,5	214,5	66	75
90-100	103	120	ER32	347,5	32	M40x1,5	35	48,5	181	83	85
90-140	103	120	ER32	387,5	32	M40x1,5	35	48,5	221	83	85
120-170	177	145	ER40	481,5	40	M50x1,5	38	61,5	300	82	120

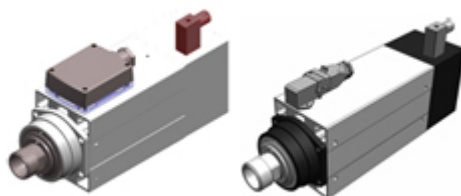

ELETTROMANDRINI CON ALBERO LINGUETTA



	Motor	Shaft	Voltage	Rotation	Speed rpm	Kw S1	Kw S6	Fixing	Connection	Cable exit
55-090	HT55a-090L	KEYED	380V	CCW	12/12000	0.65	0.85	Lateral left & right	Connector	Front
	HT55b-090L	KEYED	380V	CCW	12/12000	0.65	0.85	Lateral left & right	Connector	Rear
	HT55c-090L	KEYED	380V	CCW	12/12000	0.65	0.85	Bottom	Connector	Front

73	HT73b-045L	KEYED	380V	CCW	12/12000	0.80	0.96	Bottom	Connector	Front
	HT73a-045L	KEYED.	380V	CCW	12/12000	1.30	1.50	Lateral left & right	Connector	Rear
	HT73a-120L	KEYED	380V	CCW	12/12000	2	2.4	Lateral left & right	Connector	Rear

90	HT90a-100L	KEYED	380V	CCW	12/12000	3.5	4.2	Lateral right	Connector	Rear
	HT90a-140L	KEYED	380V	CCW	12/12000	5	6	Bottom	Connector	Front

120	HT120a-170L	KEYED	380V	CCW	6/6000	8.1	9.5	Bottom & lateral	T. box	Front
	HT120b-170L	KEYED	380V	CCW	6/6000	5.8	7.5	Bottom & lateral	T. box	Front
	HT120c-170L	KEYED	380V	CCW	6/6000	11	13.5	Bottom & lateral	T. box	Front

DIMENSIONI INDICATIVE

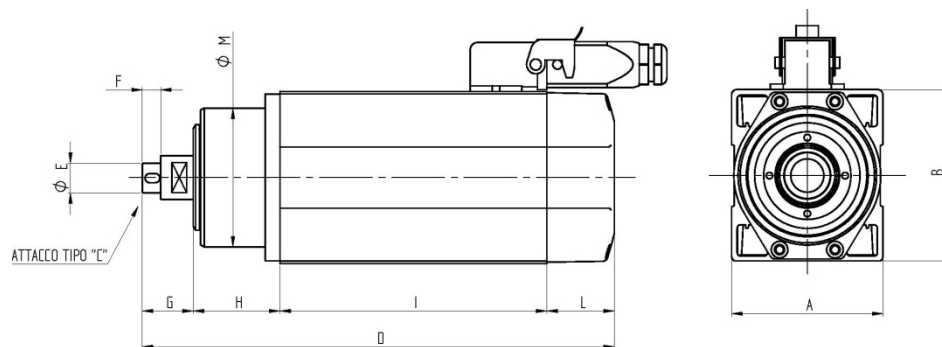

	A	B	C	D	E	F	G	H	I	L	M
55-090	73	70	Keyed	237,5	16	10	26	29,5	153	29	56
73-030	82	93	Keyed	151,5	16	5,5	6,5	25,5	83	36,5	75
73-045	82	93	Keyed	190	16	15	16	25,5	112	36,5	75
73-060	82	93	Keyed	255,5	16	10	27,5	47	144,5	36,5	75
73-120	82	93	Keyed	325,5	16	10	27,5	47	214,5	36,5	75
90-100	103	120	Keyed	330	30	64	76,5	26,5	181	46	85
90-140	103	120	Keyed	392,5	30	64,5	77	48,5	221	46	85
120-170	177	145	Keyed	490	40	80	80	55	300	55	120





VIA CARPI RAVARINO 336, 41010 LIMIDI (MODENA), ITALIA

Tel. 0039 059 561604 - 561617

Fax. 0039 059 565309

Email: info@fimec.it