

Industrial Linear Motors

Smart solutions are driven by

LinMot[®]



PRODUCT OVERVIEW

LinMot & MagSpring

We develop, build, and distribute high quality tubular style linear and linear rotary motors, modules and systems for use in industrial automation from a single source. Founded in 1993 as an independent business unit of the Sulzer Group, NTI AG has been in operation since 2000 as an independent company. Our head office is in Spreitenbach, near Zurich in Switzerland. As an international, innovative company with an experienced customer sales and support network of over 150 locations worldwide, we are always a competent and reliable partner for the realization of linear motion.

Mission

LinMot offers its customers a sophisticated and dedicated linear drive system that can be easily integrated into all leading control systems. A high degree of standardization, delivery from stock and a worldwide distribution network insure the immediate availability and excellent customer support.

Our aim is to push linear direct drive technology and make it a standard machine design element. We offer highly efficient drive solutions that make a major contribution to the overall resource conservation effort.



Our aim is to push linear direct drive technology and make it a standard machine design element.

We stand for quality and added value

NTI AG LinMot® and MagSpring® stands for excellent products and outstanding service. We believe in innovation, which is what the “I” in NTI stands for, and we are driven by an unwavering will to keep improving and work together with customers to provide them with direct drive solutions that meet their specific needs. We develop drive solutions for markets where reliability, durability, flexibility, dynamics and precision are crucial.



View the entire range of products online
shop.linmot.com

Linear Motors

LinMot motors are high quality, extremely high efficiency tubular linear motors. This high efficiency means less heat generated and better position accuracy. The simple, clean tubular design makes it easy to install the motor, reducing the footprint and achieving unrivaled force density.

Contrary to conventional drive solutions, LinMot solutions do not require any mechanical transmission elements – which simplifies the design, while reducing wear to almost zero and thus minimizing maintenance.

LinMot motors are uncompromisingly reliable, and their precise, smooth, quiet, and high dynamic motion makes them ideal for almost all applications and industries.

Core Values

Productivity

- Extreme dynamics
- Monitored process variables
- Quick and easy maintenance

Flexibility

- Freely positionable with programmable parameters
- Wide range of product combinations and options

Reliability

- High quality and precision
- Simple design
- Overload protection
- Long service life

Linear Motors Power Range

- Max. Force [N]
- Max. Cont. Force [N]

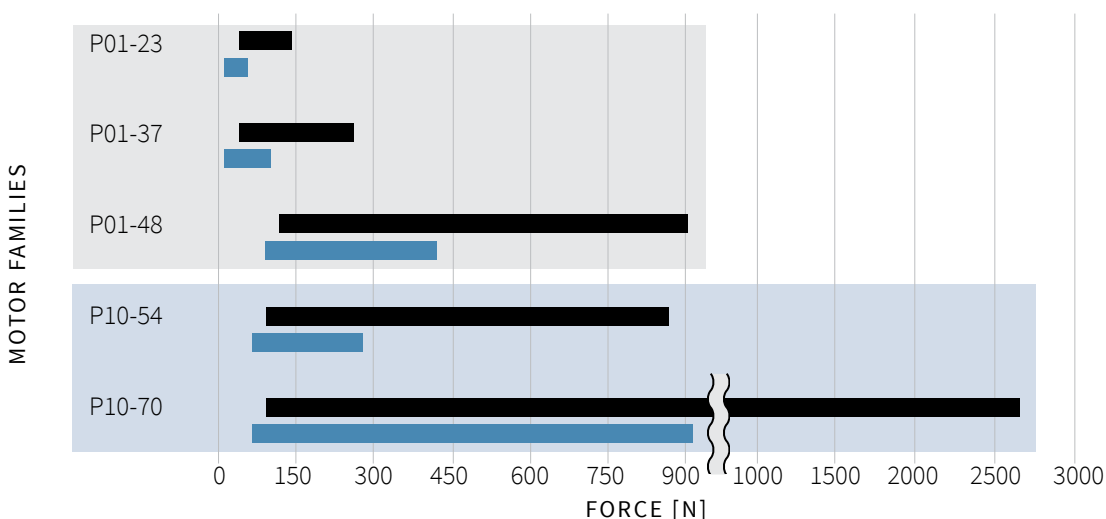



Typical Application Areas

- Plastic injection molding machines, Packaging machines, Textile machines, Assembly machines, Printing and Labelling machines
- Wood, glass, and ceramic processing machines
- Handling, Filling, Inspection, Feeding, Mounting, Stacking, Sorting and Rejection systems
- Metering, Counting, Dosing, Sealing and Precision pressing



LinMot P01

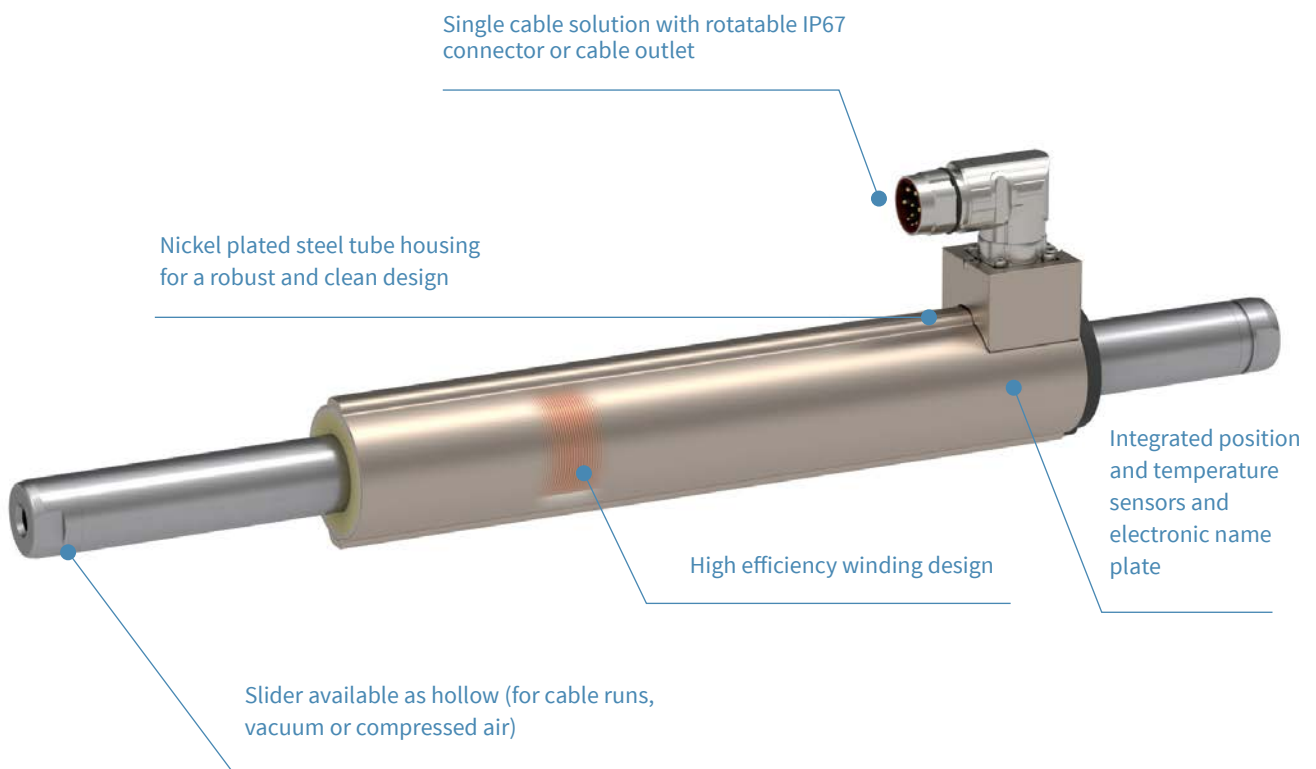

LinMot P01 linear motors are permanently actuated ironless synchronous servo motors with integrated position measurement and over-load protection. Powerful rare-earth magnets in the slider and windings in the stator are used to directly generate the linear motion.

- High power density
- Extreme efficiency
- Simple installation & configuration
- Low noise & smooth operation
- Long lifetime
- CE/RoHS/UL certified

Standard Motors

Universell



- Universal design for a wide range of applications
- Highly dynamic motors
- Available with cable outlet or with rotatable connector

Stroke up to	mm	1830
Max. Force	N	44-1024
Nominal Force	N	11-354
Peak Velocity	m/s	6.9
Repeatability	mm	0.05/0.01
Stator Length	mm	162-409

HP Motors

High-Performance



- Particularly strong magnetic circuit for an increased force and operating temperature
- High power density motors
- Increased duration of force and acceleration

Stroke up to	mm	1860
Max. Force	N	67-572
Nominal Force	N	17-297
Peak Velocity	m/s	8.2
Repeatability	mm	0.05/0.01
Stator Length	mm	162-257

Short Type Motors

Compact



- Short and light design for applications with limited space
- Integrated mounting flange
- Pluggable motor cable with cover and positionable cable outlet

Stroke up to	mm	1860
Max. Force	N	29-255
Nominal Force	N	13-68
Peak Velocity	m/s	8.2
Repeatability	mm	0.05/0.01
Stator Length	mm	90/105/150

LinMot P10

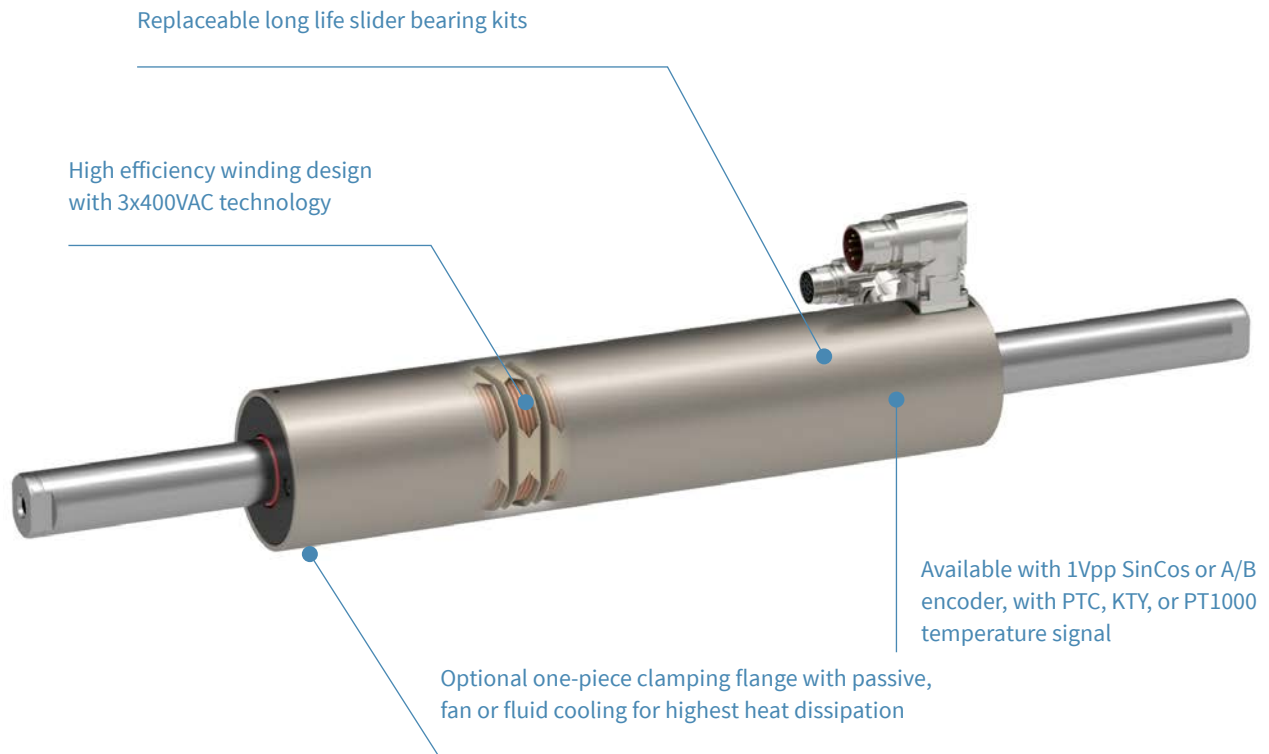

- The most powerful & dynamic LinMot motors
- 230VAC / 3x400VAC motor technology
- Controlled by standard third-party servo drives
- Long lifetime
- Easy configuration
- CE/RoHS/UL certified

P10-54 Motors

Power Packages

- 1x230VAC and 3 x 400VAC technology
- Rotating push-pull TWIN connector for power and encoder cables
- One-piece clamping flange
- Can also be controlled by standard third-party servo drives

Stroke up to	mm	2240
Max. Force	N	892
Nominal Force	N	278
Peak Velocity	m/s	11.1
Repeatability	mm	0.01
Stator Length	mm	222-402



P10-70 Motors

High Power

- 3 x 400VAC technology
- Extremely high accelerations
- Separate connector for sensor and power cable
- Can also be controlled by standard third-party servo drives

Stroke up to	mm	1770
Max. Force	N	557-2720
Nominal Force	N	68-914
Peak Velocity	m/s	7.4
Repeatability	mm	0.05/0.01
Stator Length	mm	180-500



Linear Modules & Guides

LinMot linear modules & guides are precise, ready to install linear systems that are energy efficient and require minimal installation space. These products offer high guidance accuracy and facilitate dynamic and precise positioning of the load while supporting external forces, torques, and bending moments.

The product portfolio covers different performance classes with all required stroke lengths that guarantee millions of precise load changes. Between the linear modules and guides, you can choose from different sizes, countless stroke lengths and many available options. We offer you the optimal solution whatever the application.

Linear Modules & Guides

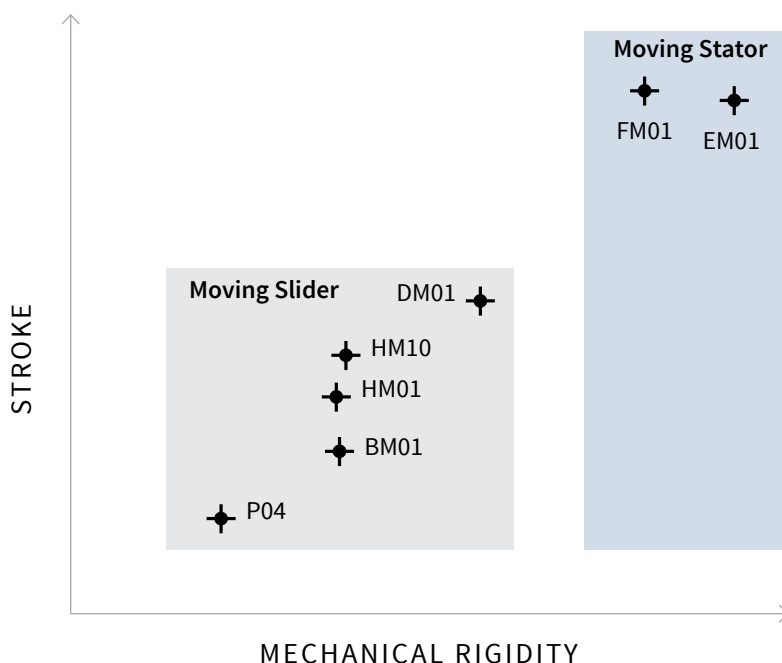

Core Values

Simplicity

- Fully assembled and tested, Ready-to-Install
- All components from a single source
- Quick commissioning

Flexibility

- For low and high payloads
- “On the fly” programmable parameters
- Various sizes for compact mounting and optimal coverage

Reliability

- High quality and precision
- High repetition accuracy
- Optimized design for maximum mechanical rigidity
- Long service life

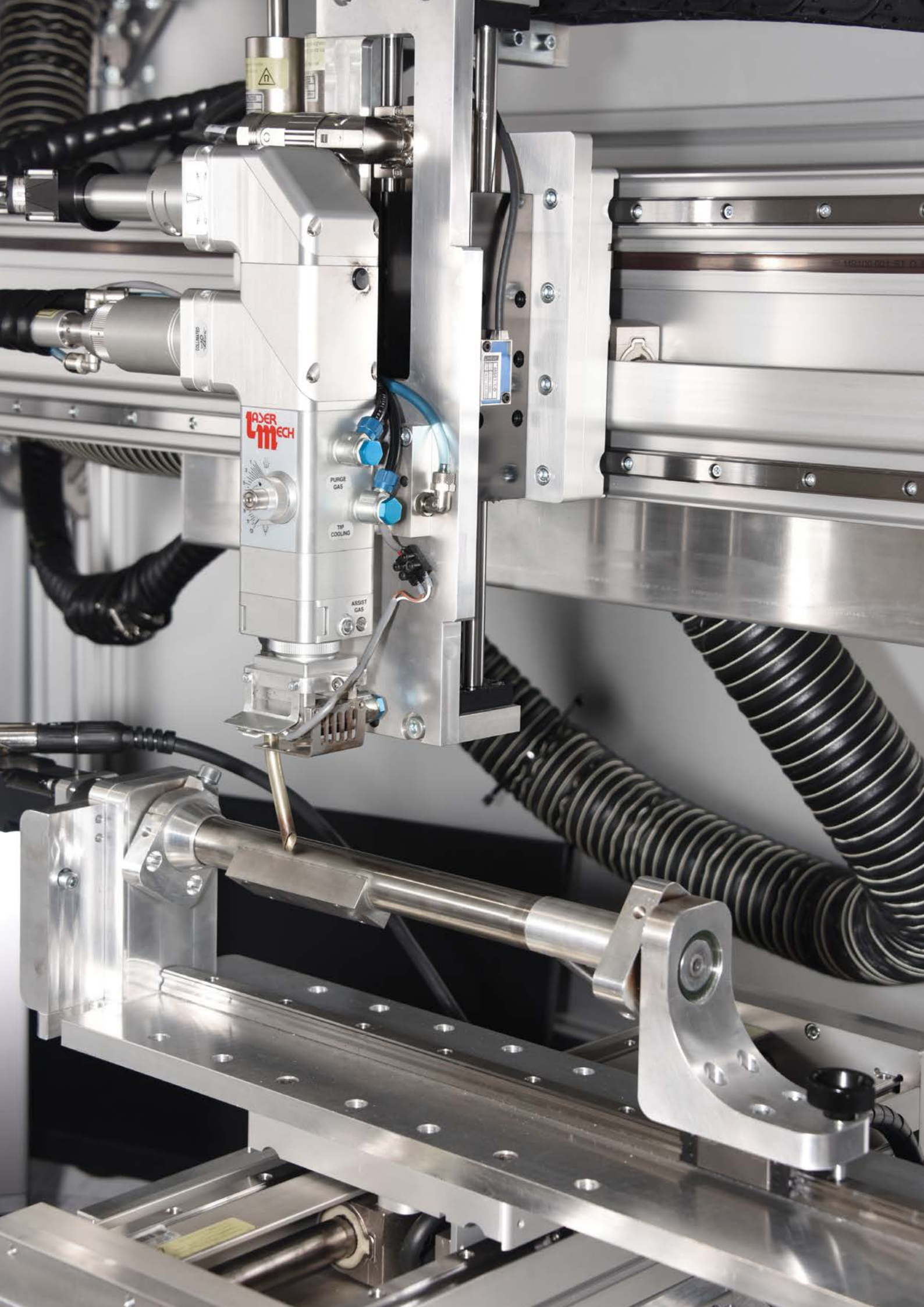

Linear Modules & Guides

Moving Slider

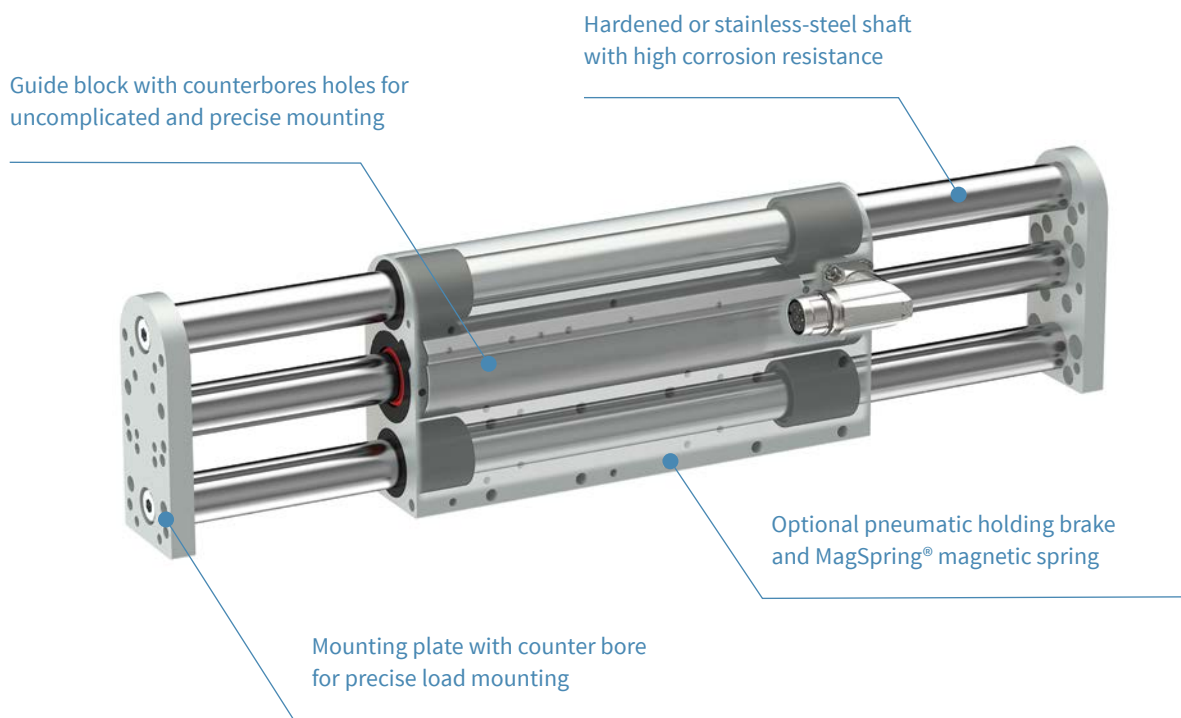

Our moving slider linear modules & guides allow for dynamic and precise load positioning in a very compact package with exceptional running properties. The load is connected directly to the front plate of the unit, while their optimized design makes their installation effortless, hence resulting in modules and guides that are extremely easy to use. Compared to the solution with pneumatic cylinders, they offer a significant improvement in terms of cycle time, efficiency and energy savings. The modular principle also offers you a comprehensive range of product variants with a large selection of sizes, forces and options. LinMot linear modules & guides with moving slider

are uncompromisingly reliable and are suitable for all types of tasks with their precise, smooth and highly dynamic linear movement.

- Compact and simple design
- Precise and smooth movement
- High dynamic response and travel speed
- Outstanding running properties
- Long service life
- High modularity & easy to use

DM01 Linear Modules

Complete Drive Solution



- Higher bending stiffness
- Anodized aluminum housing for easy cleaning
- Corrosion-resistant, hard chrome-plated guide rods
- Linear ball bearings with food grade lubricant (NSF H1) and no slider lubrication
- One part, one article number, ready-to-install
- Quick commissioning and reduced engineering effort

Stroke up to	mm	575
Max. Force	N	67-572
Moving mass	g	460-8860
Maximum load	g	30000
Peak Velocity	m/s	7.4

OPTION

Integrated Force Sensor

- Decoupled force measurement
- Arbitrary load mounting
- High measuring accuracy
- Process control based on force profile



OPTION

Clean Room IS04



NTI AG – LinMot
Report No. NT 2009-1177

P04 Linear Modules

The Motor to replace Pneumatics



- Mounting connections according ISO cylinder standard
- Hardened rod capable to handle side load
- Motor with integrated guidance for pneumatic - replacement and harsh environments

Stroke up to	mm	80-150
Max. Force	N	255-572
Moving mass	g	1190-3100
Maximum load	g	9000

Linear Modules & Guides

Moving Stator

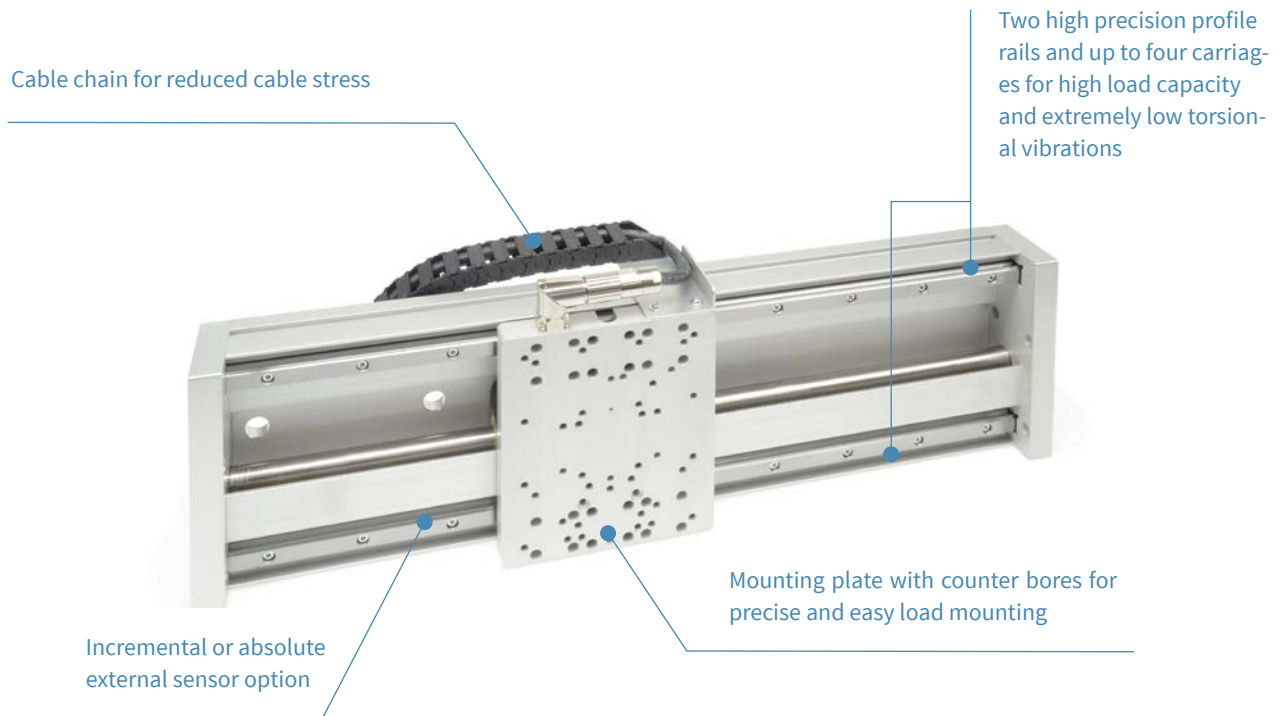

Our moving stator linear modules & guides offer a high guidance accuracy, a precise load positioning and a reliable operation even with heavy loads and over a long distance. They consist of a special aluminium profile on which up to 2 high precision rails with up to 4 linear ball bearing carriages can be mounted.

They can be mounted together into a gantry or semi gantry design without any additional adapters and are mechanically compatible with many LinMot products. All of this, in addition to the fact that multiple stators can be driven on the same guide, makes the moving stator guides a powerful toolbox for any automation task.

Rigid & precise

Stroke lengths up to 2m

High dynamic response

Adapterless connection for gantry systems

Long service life & easy load installation

Preassembled, Ready-to-Install

FM01 Linear Modules

Compact with high Load Capacity

- Compact, high dynamic module for long stroke applications and multi-axis configurations
- High accuracy, high rigidity, high speed
- High precision profile rail guide
- High mechanical compatibility with LinMot products
- Configurable with one or more motors per guide



Stroke up to	mm	2150
Max. Force	N	128-1020
Moving mass	g	1100-5850
Peak Velocity	m/s	4.93

EM01 Linear Modules

Extremely High Stiffness

- High load capacity module for applications where stability and moment load support is paramount
- High motion accuracy, extreme load capacity and rigidity
- 2 high precision profile rail guides with up to 4 carriages
- High mechanical compatibility with LinMot products
- Configurable with one or more motors per guide



Stroke up to	mm	1838
Max. Force	N	128-572
Moving mass	g	2140-5970
Peak Velocity	m/s	4.93

Linear Rotary Motors

Linear rotary motors from LinMot are characterized by excellent flexibility, dynamics, and reliability. They combine two electromagnetic servo motors in just one slim housing and thus enable combined linear and rotary movements in the simplest way. Complex tasks such as closing, screwing, or assembling and much more may be realized with this single component.

The virtually wear-free modules also offer outstanding availability and can be equipped with many options. LinMot offers linear rotary motors in two different series.

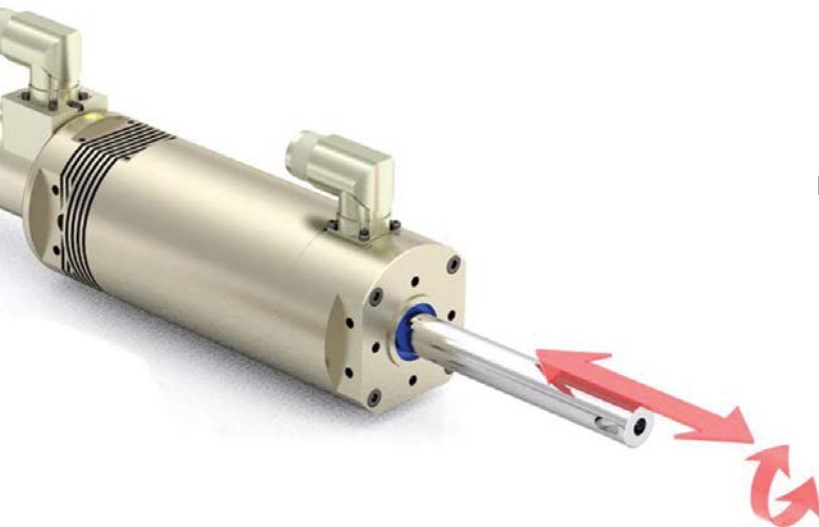

Core Values

Simplicity

- Fully assembled and tested, ready-to-Install
- Simple installation
- All components from a single supplier
- Quick commissioning

Flexibility

- Two independent motions in one housing
- “On the fly” programmable parameters
- Various sizes with different designs for optimal mounting
- Smooth changeover between position and force or torque control
- All motors with a wide variety of integrable options

Reliability

- High quality and precision
- Simple and clean design
- High repetition accuracy
- Long service life

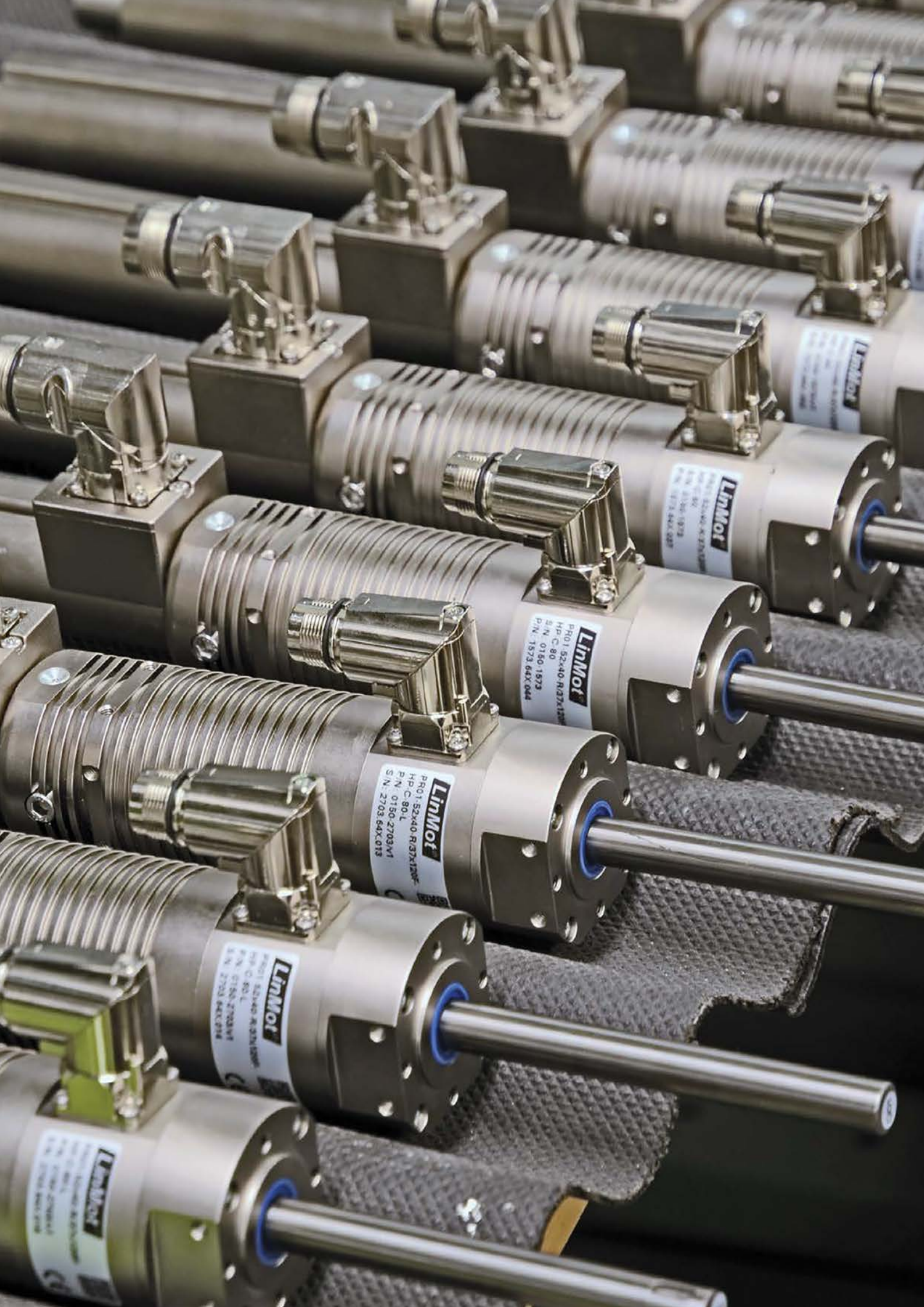

LinMot
PR01-52x40-R/37x120-
HP-C-80-L
S/N: 0150-2703M1
P.N.: 2703-64X013

LinMot
PR01-52x40-R/37x120-
HP-C-80
S/N: 0150-1973
P.N.: 1573-64X044

LinMot
PR01-52x40-R/37x120-
HP-C-80
S/N: 0150-1973
P.N.: 1573-64X044

LinMot
PR01-52x40-R/37x120-
HP-C-80-L
S/N: 0150-2703M1
P.N.: 2703-64X013

LinMot
PR01-52x40-R/37x120-
HP-C-80-L
S/N: 0150-2703M1
P.N.: 2703-64X013

Linear Rotary Motors

PR01 Series

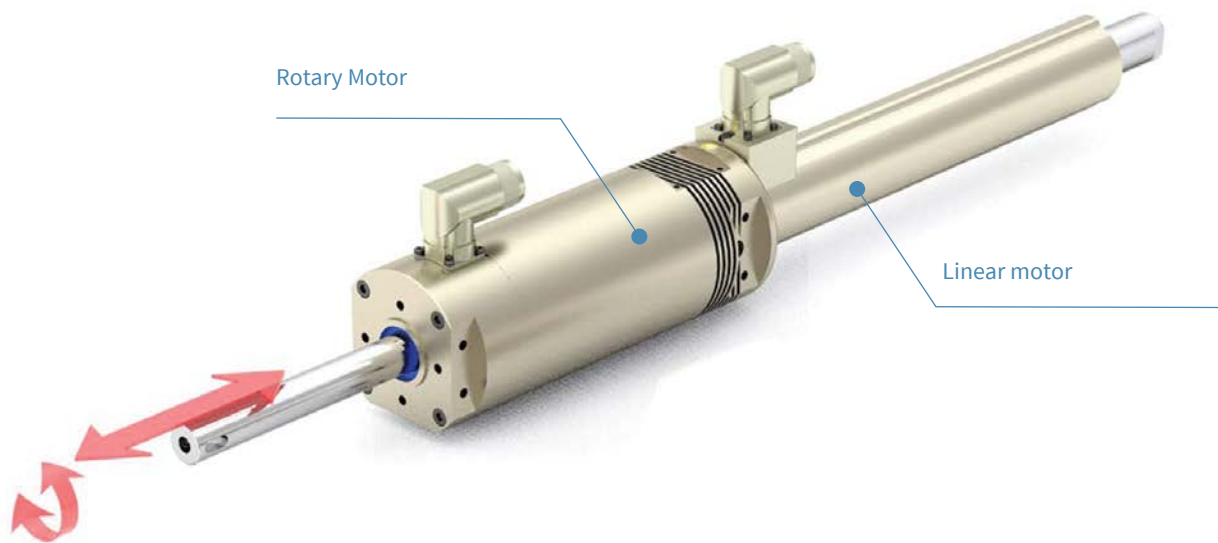

The PR01 product family combines a linear and a rotary motor in just one housing. The two electromagnetic servo motors are built in series and thus enable the installation of this machine element in the smallest possible footprint. Numerous options such as the MagSpring load compensation, pneumatic brake, cam kit and wiper can be added to the module.

The modules are also available with a gearbox for higher torques, stainless steel front and with an integrated hole through the entire module for vacuum and compressed air feed-through.

Simple implementation of capping & assembling systems

Synchronized or independent linear and rotary motions

Programmable press forces and torques

High dynamic response

Long service life

Stroke lengths up to 300 mm

Torque up to 100 Nm

Linear Rotary Motor

- Linear direct drive
- Rotary direct drive
- Independent linear and rotary motions
- Integrated position sensors
- Absolute temperature feedback
- Programmable position / motion profiles
- Programmable press force
- Programmable torque
- Endless turning
- Single turn absolute position encoder

Option Hollow Shaft

- Version with hollow shaft
- Inner diameter 2.5 / 4.0 mm
- Upgradeable to vacuum gripper
- Can be combined with a pneumatic or electric gripper

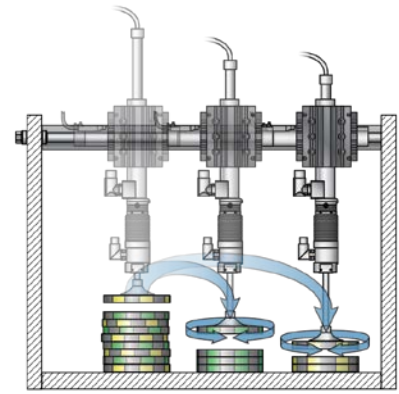

Stroke up to	mm	300
Max. Force	N	229-1024
Nominal Force	N	51-203
Peak Velocity	m/s	3.9
Peak Torque	Nm	1.5-8.9
Constant Torque	Nm	0.32-1.9
Max. Num. of Rev.	rpm	1000-1500
Repeatability	mm	0.05/0.01
Length	mm	503-1222

Stainless Steel Front

- Linear rotary shaft and module front in stainless steel EN1.4404 / AISI 316
- Hygienic Design
- Resistant to cleaning supplies
- Designed for use with food products
- Designed for use in the chemical industry
- With interchangeable plain bearings



Linear Rotary Motors with Gearbox

- Independent linear and rotary motions
- For applications with high inertia loads
- For applications with high torque requirement
- 3 selectable transmission ratios
- With guide rails to bear transverse loads



Max. Stroke	mm	150
Max. Force	N	1024
Nominal Force	N	203
Peak Velocity	m/s	3
Gear	n	1:5/1:7/1:10
Peak Torque	Nm	40/56/75
Constant Torque	Nm	8.2/12/17



Linear Rotary Motors

PR02 Series

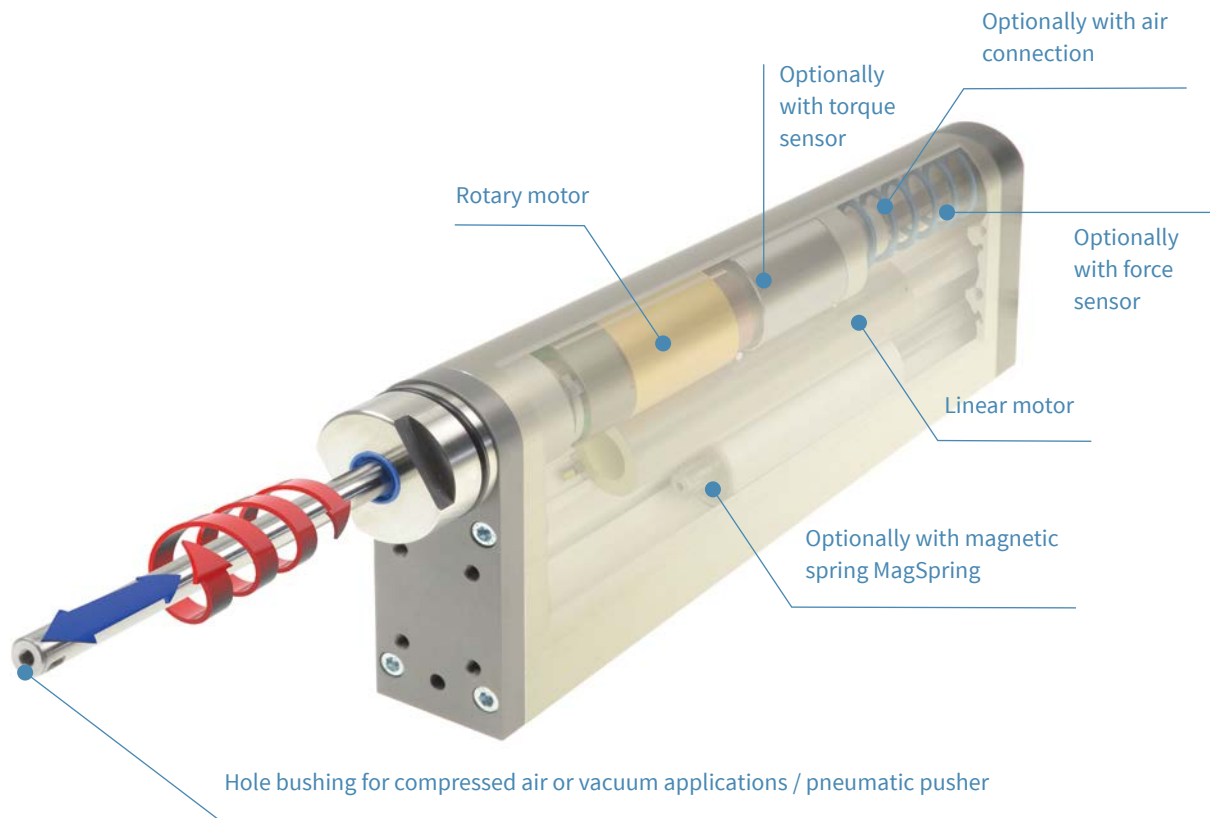

The PR02 motor series is characterized by a design wherein the motors and additional components are integrated in a slim easy to clean housing. Options can be installed such as a hollow shaft, pneumatic pusher, a magnetic spring “Mag-Spring”, a torque sensor, and a force sensor.

The innovative PR02 delivers all necessary data packages for networked production in the sense of “Industry 4.0”. With the help of real time motor information and optional additional sensors, detailed information, such as the vertical position, press force or impact force, closing angle and torque are available.

Simple implementation of capping & assembling systems

Synchronized or independent linear and rotary motions

Programmable / measurable forces and torques

High dynamic response

Long service life

Stroke lengths up to 300 mm

Torque up to 10 Nm

Easy to clean surface

Sizes 38/52/88



Stroke up to	mm	300
Max. Force	N	67-572
Nominal Force	N	25-230
Peak Velocity	m/s	2.9 - 7.3
Peak Torque	m/s ²	1.2-10
Constant Torque	Nm	0.32-2.64
Max. Num. of Rev.	rpm	1000-1500
Repeatability	mm	0.05/0.01
Length	mm	350 - 1018

New PR02-70



Stroke up to	mm	240
Max. Force	N	572
Nominal Force	N	200
Peak Velocity	m/s	3
Peak Torque	m/s ²	9
Constant Torque	Nm	2
Max. Num. of Rev.	rpm	1000
Repeatability	mm	0.05/0.01
Length	mm	600 - 825

Hollow Shaft - Option

Option hollow shaft offers a feed through air possibility through the entire module for operating pneumatic grippers or for suck elements via vacuum. There is no need for a pneumatic hose around the module shaft and endless rotation is possible.

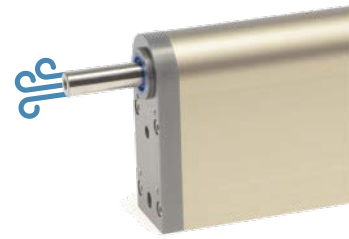

Pusher - Option

Option pusher allows users to have a second axial, telescopic movement. Gripping elements may be emitted or mechanical grippers are operated using this option. Integrated pneumatic cylinder is double-acting.



Stroke	mm	20
Max. Force @ 6 bar	N	400
Pusher diameter	mm	8

MagSpring - Option

A properly sized MagSpring ensures that the tooling and motors moving mass are passively compensated for, preventing the axis from falling in event of a power loss. MagSpring force is available in different sizes and its working direction may be pulling or pushing.

Force- & Torque Sensor – Option

Torque and force sensors enable precise, reproducible, and recordable capping and assembling processes often required in pharmaceutical or medical industries.

Due to continuous real time process monitoring every assembled unit can be traced.

- Calibrated force and torque sensors
- Closed loop force / torque control
- Real time process monitoring
- High precision capping & assembling processes
- Data gathering and process evaluation
- Industry 4.0

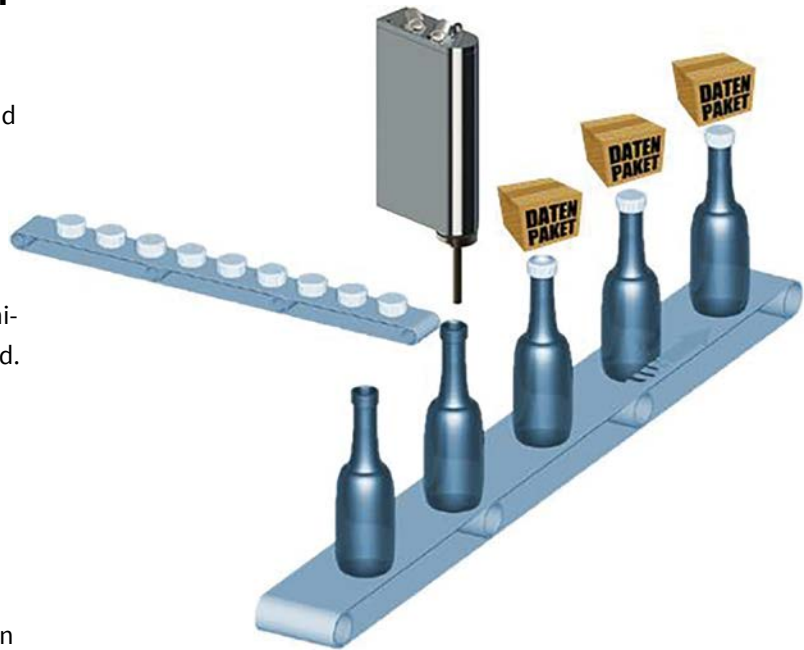

Stainless Steel Front – Option

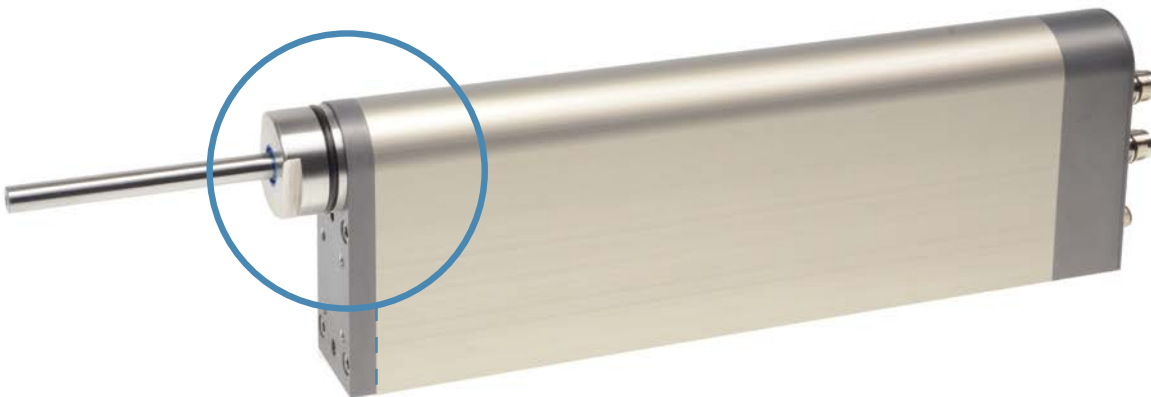

Wash-down and cleaning zone (IP69-S)

Standard machine zone (IP64)

- Linear rotary shaft and front in stainless steel EN 1.4112; 1.4404 / AISI 440; 316
- Hygienic Design
- Resistant to cleaning supplies
- Designed for use with food products
- Designed for use in the chemical industry
- With interchangeable ball bearings
- Combinable with other options like integrated force and torque sensors

MagSpring

Weightlessness in your application

When installed vertically, linear motors and other direct drives must apply a constant force to counteract the force of gravity.

This is exactly why LinMot has developed the «Magnetic Spring» MagSpring.

Mounted parallel to the linear motor, the weight force can be passively compensated via the MagSpring. When the vertical axis de-energizes, the MagSpring may prevent lowering of the vertical axis. Utilizing a MagSpring the linear motor is used only for actual positioning and application of dynamic forces, thus allowing smaller dimensioned motors.

The functionality is based on the attraction of the permanent magnet. Accordingly, no power supply (electricity, compressed air, etc.) is necessary, allowing easy implementation of safety-related applications.



Thanks to the constant power path characteristic numerous applications are possible, such as position-independent generation of a constant contact force, the application of a constant holding force over a large stroke range or the unilateral power assistance in driving tasks.

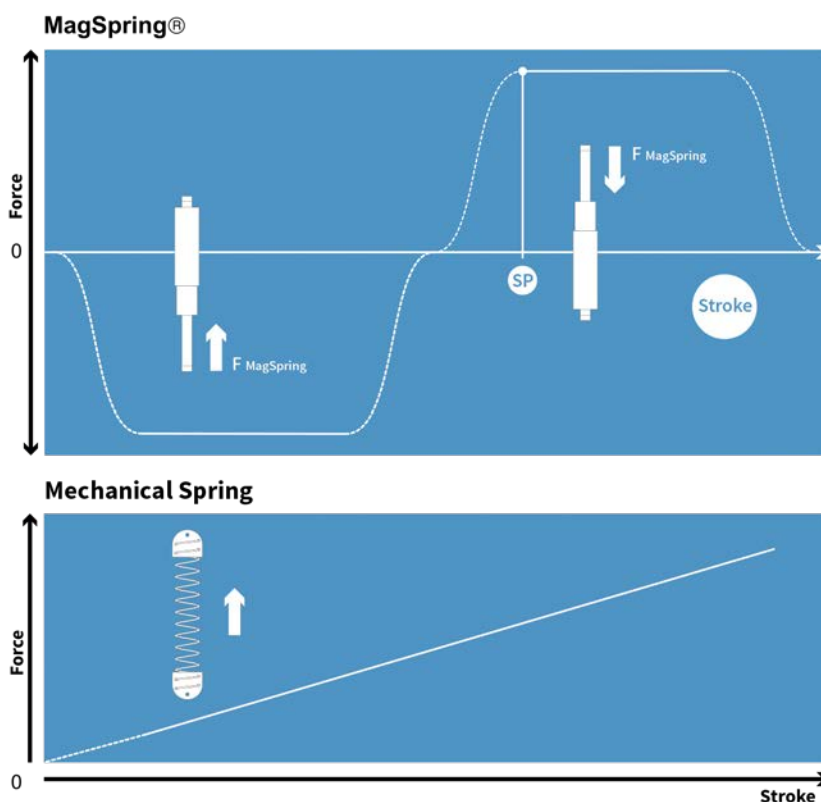

M01-20			M01-37			M01-40 Stainless Steel		
Constant force	N	11 / 17 / 22	Constant force	N	40 / 50 / 60	Constant force	N	40/50/60
Stroke (Constant force)	mm	≤ 290	Stroke (Constant force)	mm	≤ 350	Stroke (Constant force)	mm	<350
Stator mass	g	75 - 388	Stator mass	g	440 - 2200	Stator mass	g	440-2200
Slider mass	g	75 - 280	Slider mass	g	75 - 420	Slider mass	g	75-420

Product characteristics

- Constant force along the entire stroke
- Purely passive, no electricity needed nor compressed air
- Ideal for compensating the gravitational force
- Also suitable for dynamic movements
- Different stroke ranges and forces
- Can be combined with various LinMot linear modules
- Simple construction



Stainless Steel Products

LinMot motors and modules are manufactured using the highest grade stainless steel to meet the requirements of the most demanding environments. With hygiene as a primary goal, LinMot motors and modules are designed without unnecessary edges, corners, holes, and threads that prevent the build-up of bacteria and dirt pockets, while the FDA approved bearing material is specifically designed for use in the food and pharmaceutical industries. Our corrosion resistant and hygienic design products allow hygienic and sterile automation close to the process. This simplifies and lowers cost of machine design by eliminating the need for protective guards around standard actuators and allows for a new design freedom. Cleaning is also made quick and easy thanks to the open machine design and is extremely reliable even with frequent high-pressure and high-temperature cleaning thanks to its IP69 protection rating.

Core Values

Quality & Reliability

- Designed for industrial use and adverse conditions
- Extremely reliable with any type of cleaning
- High-quality 316L stainless-steel housing
- Robust IP69 hygienic design with high power density
- FDA approved bearing material
- Low maintenance, long service life

Productivity, Simplicity, Flexibility

- Extreme dynamics
- Reduced cleaning times
- Space saving round design
- Single cable solution
- Simple machine installation
- Easy connection to your field-bus system

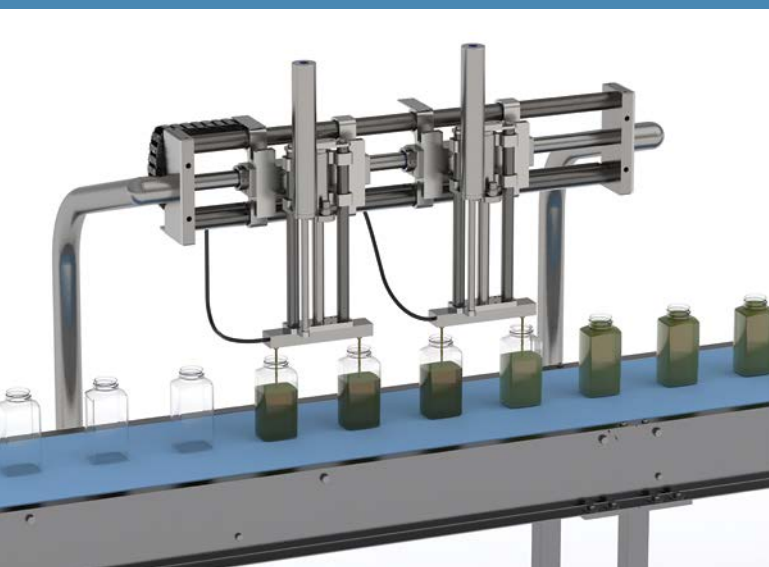

Typical Application Areas

- Precise cutting, portioning, trimming, skinning, deheading, degutting, grading and 3D printing in the food Industry
- Precise filling, dosing, positioning, adjusting, stacking, sorting, aligning, packaging, and labelling in the pharmaceutical, medical, cosmetic, and chemical industry



Stainless Steel Linear Motors

The stainless steel family of motors consists of different sizes and designs which cover a wide range of strokes and forces. These motors can be used in machines and systems in the food, beverage, and pharmaceutical industry. They improve the overall equipment effectiveness thanks to significantly reduced cleaning times; are capable of handling extremely rough or corrosive environments without a problem and can be cleaned with any typical industrial cleaning products.

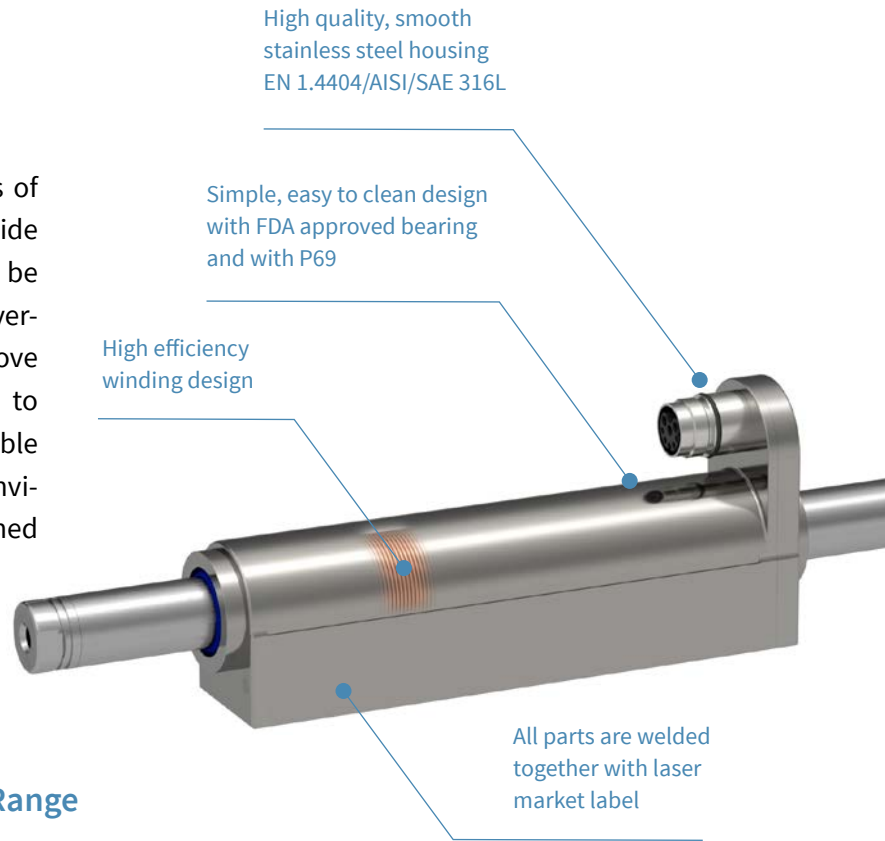

Stainless Steel Linear Motors Power Range

■ Max. Force [N]
 ■ Max. Cont. Force [N]

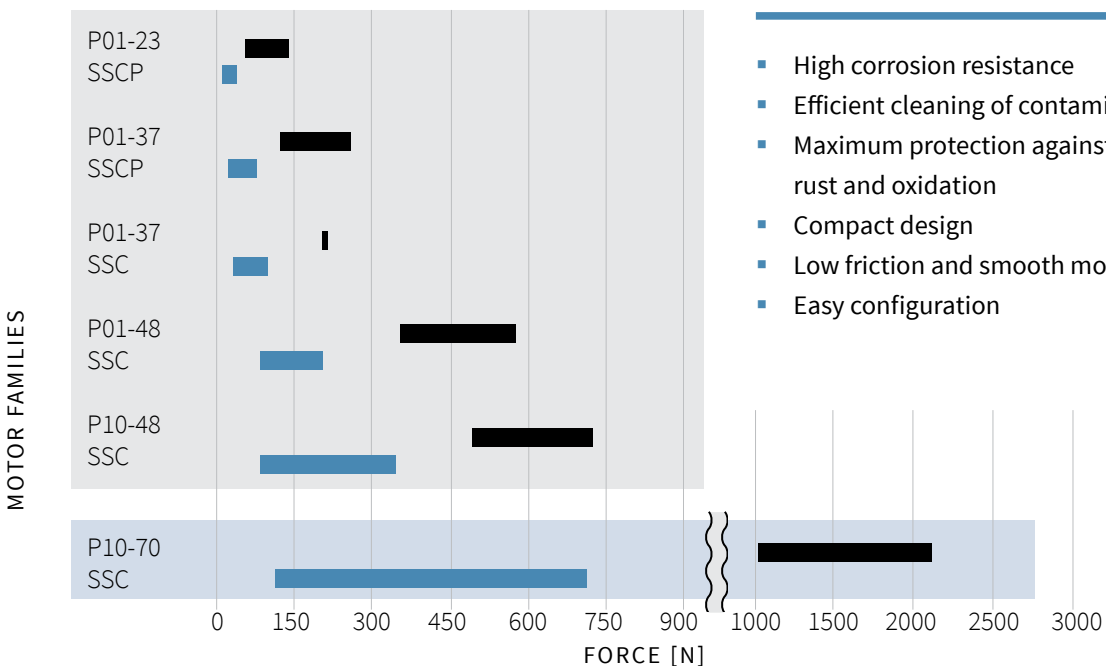

Core Values

- High corrosion resistance
- Efficient cleaning of contamination
- Maximum protection against flash rust and oxidation
- Compact design
- Low friction and smooth movement
- Easy configuration

SSCP Motors

Performant and compact



- Compact design and excellent thermal behaviour thanks to new optimized design
- Integrated mounting flange for simple machine installation
- Reduced effort with single cable technology
- Cable outlet option with IP67 connector

Stroke up to	mm	1455
Max. Force	N	67-550
Nominal Force	N	12-198
Peak Velocity	m/s	7.4
Repeatability	mm	±0.05
Stator Length	mm	120-317

SSCP Slim Motors

Extremely compact



- Simple and slim design, up to 1225 motors on 1 m²
- Available with integrated mounting flange for flexible fastening and efficient heat dissipation
- Single cable outlet with 2 connector options

SSC Motors 3x400VAC

High Power



- 3x400VAC technology
- Water cooling integrated in the housing
- Can also be controlled by standard third-party servo drives

Stroke up to	mm	1610
Max. Force	N	1120-2180
Nominal Force	N	115-710
Peak Velocity	m/s	6.4
Repeatability	mm	±0.05
Stator Length	mm	350-420

SSC Motors

Standard



- Best design for fluid cooling
- Completely encapsulated
- External replaceable FDA approved bearings

Stroke up to	mm	1070
Max. Force	N	210-694
Nominal Force	N	36-363
Peak Velocity	m/s	4.7
Repeatability	mm	±0.05
Stator Length	mm	296-515

Stainless Steel Linear Modules

FDA approved linear plain bearing or linear ball bearing option and food grade lubricant (NSF H1)

Hygienic stainless steel motor with high protection class



Mounting plate with counter bore

Hardened stainless steel shafts option with high corrosion resistance

As the benchmark for chemical resistance, durability, speed and precision in linear actuators, LinMot stainless steel modules open new doors in the food and pharmaceutical environment. These products offer high guidance accuracy and facilitate dynamic and precise load positioning, maximizing productivity with little downtime for cleaning and maintenance. Installation into the machine is extremely simple as the modules come fully assembled and the load can be easily connected. Commissioning is quick thanks to the single-cable solution and plug and play technology. The modular principle offers a full range of prod-

uct variants that can be mounted together in a gantry, semi-gantry or pick and place design.

Low friction and smooth movement

Low maintenance, long service life

Suited for hygienic and sterile production

Designed for “in-place” cleaning processes such as CIP and SIP

Direct mounting of the load with absorption of transverse forces

SM01 Modules

Moving Sliders

- Precise and smooth movement
- No slider lubrication
- Stainless steel MagSpring option
- Automatic motor parametrization thanks to the electronic identification plate

Stroke up to	mm	100-765
Max. Force	N	128-477
Moving mass	g	26-172
Peak Velocity	m/s	4.9



SM02 Modules

Moving Stator

- High dynamic guide for long stroke applications
- Can be mounted into gantry design
Delivered preassembled
- Automatic motor parametrization thanks to the electronic identification plate

Stroke up to	mm	310-1010
Max. Force	N	255-550
Moving mass	g	48-160
Peak Velocity	m/s	3.9



H01 Stainless Steel Guide

Guides for SSC Motors

- Compact guide for SSC motors with high clearance sliders
- FDA approved bearing
- Hardened stainless steel shaft
- External replicable bearing

Stroke up to	mm	58-510
Max. Force	N	210-477
Moving mass	g	36-240
Peak Velocity	m/s	4.7



Stainless Steel Linear Rotary Motors



Stroke up to	mm	110
Max. Force	N	255
Max. Torque	Nm	2.2
IP		69S



Stroke up to	mm	100
Max. Force	N	255
Max. Torque	Nm	2.2
IP		69S

The “SSCH” stainless steel housing option extends the SSC front option and wraps the entire linear rotary motor with a stainless-steel housing. As a result, such motors have a high IP protection class (IP69s) for the whole motor and can withstand “in place” cleaning processes such as CIP and SIP. They are specially designed for the food or pharmaceutical & medical industry.

Designed for pharmaceutical applications and food sector

Suitable for “wash-down” with protection class IP69 S

High chemical resistance

Motor housing and linear rotary shaft in stainless steel

Integrated MagSpring for load compensation

Hollow shaft for vacuum and compressed air feed-through



ATEX Motors

High quality, smooth stainless steel housing
EN 1.4404/AISI/SAE 316L

Optional fluid cooling

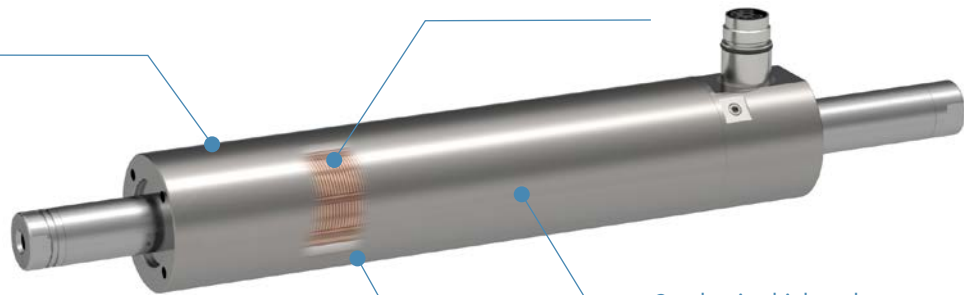

Conductive high end
polymer bearings

Four temperature sensors
inside the housing

In a surrounding where explosive gases, vapor-air mixture or combustible dust can form, special electric motors are required. LinMot ATEX has been developed exactly for those special conditions. The motors are built with the awareness to operate in an explosive environment. For this, the stator is completely encapsulated with epoxy resin and an additional temperature monitoring is integrated into the motor as the surface temperature is of crucial importance in an explosive atmosphere.



Typical Application Areas

- Filling, metering, dosing of beauty products, cosmetics, alcoholic liquids, cleaning agent and much more
- printing machines, plastic processing machine or In chemical, petrochemical, and pharmaceutical industries

Stroke up to	mm	1070
Max. Force	N	312-721
Nominal Force	N	59-389
Peak Velocity	m/s	4.8
Repeatability	mm	0.05/0.01
Stator Length	mm	305-515

Customized Products

Tailored to your specific requirements

Stainless Steel Motor with integrated drive

Protection Class IP69

- Especially for applications in the pharmaceutical and food industry with very tight spaces
- Welded connections
- Completely encapsulated (IP69K)
- Special designed connector
- Control via fieldbus or Industrial Ethernet



Linear Motors PD03

Integrated Drive

- High-performance linear motor with integrated drive
- Compact form factor
- Highly dynamic
- Suitable for daisy-chain linkages
- Integrated mounting flange
- Low cabling effort
- Low overall costs
- Simple commissioning

Stroke up to	mm	135
Max. Force	N	255
Nominal Force	N	35
Peak Velocity	m/s	3.2
Peak Acceleration	m/s ²	450
Repeatability	mm	±0.05
Stator Length	mm	400
Slider Length	mm	240



System Integration

LinMot Products can be integrated in all major control systems

SIEMENS



BECKHOFF



Schneider Electric

BOSCH

Controller



DeviceNet

EtherNet/IP



CANopen

Communication Interfaces



LinMot Drives



24...72 VDC



LinMot Motors



Voice Coil



EC/DC Motor



Linear Motor

OMRON

Lenze

CODESYS

NATIONAL INSTRUMENTS
LabVIEW™

MATLAB®
SIMULINK®

KEB



ETHERNET
POWERLINK

EtherCAT®

sercos
the automation bus

RS 485

RS 232

CC-Link IE Field



3 x 400 VAC

LinMot Drives



3rd Party Drives



P10-54 P10-70



AC Servo



P10-54 P10-70



AC Servo

Servo Drives

The comprehensive range of LinMot servo drives impresses with its speed, high flexibility and wide range of functions. In addition, they can be easily integrated into any type of application. Our drives are designed for precise control, an optimal force/torque ratio and a wide range of functions. We thus optimally complement the wide range of linear motors, integrated linear modules as well as the linear rotary motors. Another decisive factor is that our servo drives are easy to operate and work reliably - saving you time and money.



Flexibility & Connectivity	Safety & Reliability	Simplicity
Wide range of applications, from point to point to complex multi-axis applications	Drives available with and without STO	Automatic detection and parametrization via bus
Analog, digital or serial interfaces, field-buses, and real time ETHERNET	Functional safety with SLS, SOS, SS1, SS2, SBC, SBT	Compact design, easy installation and commissioning
Functions such as Force / Torque control and Process Monitoring	Calibrated Measuring Amplifier option for measuring applications with calibration certificate in addition to CE and UL	Preprogrammed functional blocks and examples

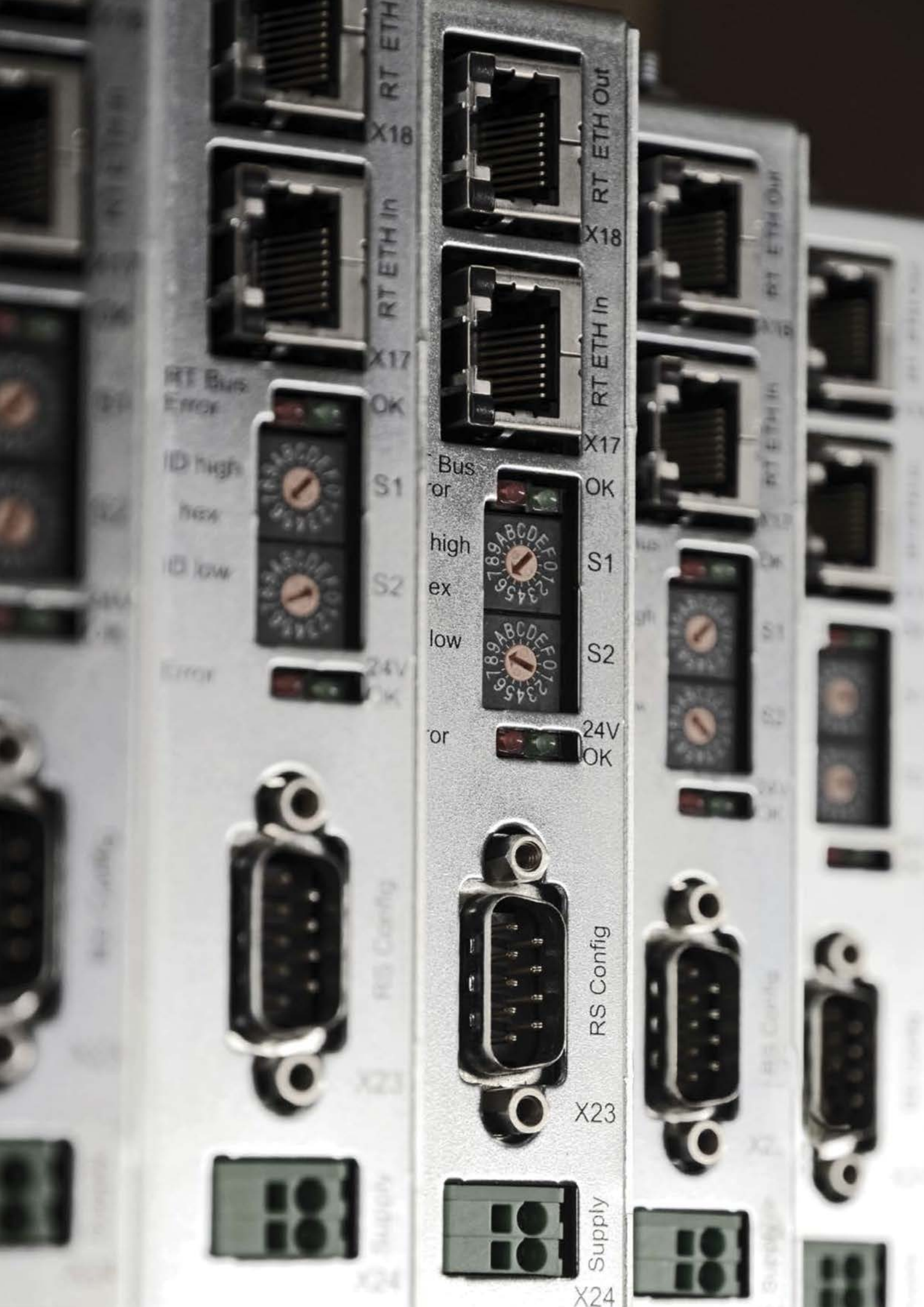

RT ETH X18

RT ETH In X17

RT Bus Error

ID High

OK

ID Low

Error

Control panel with two rotary switches labeled S1 and S2, and a 24V OK indicator.

Bus or high ex low

Control panel with two rotary switches labeled S1 and S2, and a 24V OK indicator.

or 24V OK

RS Config D-sub connector (X23)

Supply connector (X24)

RT ETH Out X18

RT ETH In X17

OK

S1

S2

24V OK

RS Config X23

Supply X24

C 1200

Compact Drive / NC Motion

- 24...72VDC
- Real Time (Streaming)
- Synchronous control (Drive profiles)
- Configuration over Industrial Ethernet (EoE)
- Digital and Analog IO's
- Calibrated measuring amplifier
- Process monitoring
- Safe Torque Off
- Interface for optional incremental and absolute sensor
- Supports Plug and Play
- PLC or Stand-Alone Solutions
- CE/UL/CSA



EtherNet/IP



EtherCAT

ETHERNET POWERLINK

SERCOS
the automation bus

CC-Link IE field

C 1100

Compact-Drive / Point to Point



- 24...72VDC
- Real Time (Streaming)
- Digital and Analog IO's
- Interface for optional incremental and absolute sensor
- Supports Plug and Play
- PLC or Stand-Alone Solutions
- Safe Torque Off
- CE/UL/CSA



EtherCAT

CANopen

A 1100

Small Drive for Instrument Engineering



- 24...72VDC
- PLC or Stand-Alone Solutions
- Digital IO's
- Supports Plug and Play
- CE/UL/CSA

CANopen

C 1251-2S

Functional Safety Drive

- Integrated functional safety
- Safe fieldbus communication; safe digital IO's
- Up to SIL 2 (EN 61508) and PL d (EN ISO 13849)
- Multi-interface drive to reduce storage, spare parts & service costs
- Configuration & Backup via SD card
- Process monitoring & real time data evaluation
- 24...72VDC
- Real Time (Streaming)
- PLC or Stand-Alone Solutions
- Synchronous control (Drive profiles)
- Calibrated measuring amplifier
- Configuration over Industrial Ethernet (EoE)
- CE/UL/CSA

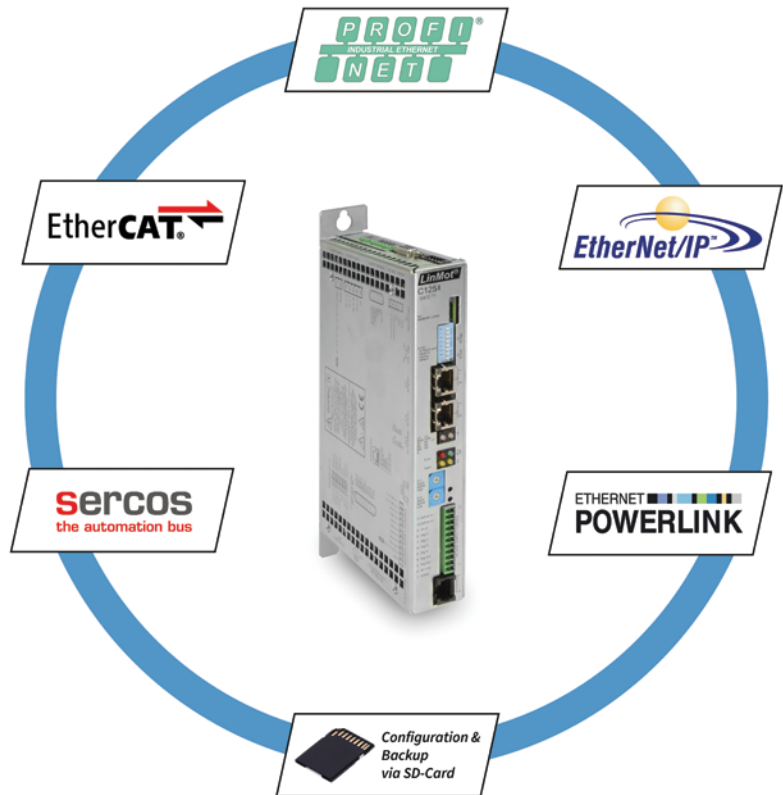

E 1200

High End Drive



- 24...72VDC
- Real Time (Streaming)
- Synchronous control (Drive profiles)
- Industrial Ethernet Configuration / Remote Access Ethernet
- Master Encoder Synchronization (In/Out)
- Master / Slave Solutions
- ± 10 VDC Force / Speed Control
- Supports Plug and Play
- Digital and Analog IO's
- PLC or Stand-Alone Solutions
- Interface for optional incremental and absolute sensor
- Position Encoder Simulation (RS 422)



E 1400

High End Drive

- 3x400...480VAC
- Controls LinMot motors / AC servomotors
- Absolute / relative positioning commands
- Limited jerk motion commands
- Time Curves
- Real Time (Streaming)
- Synchronous control (Drive profiles)
- Master Encoder Synchronization (In/Out)
- PLC or Stand-Alone Solutions
- Industrial Ethernet Configuration / Remote Access Ethernet
- Digital and Analog IO's
- Safe Torque Off
- Interface for optional incremental and absolute sensor
- Position Encoder Simulation (RS 422)
- Master / Slave Solutions
- ± 10 VDC Force / Speed Control
- Supports Plug and Play



EtherNet/IP

EtherCAT

ETHERNET
POWERLINK

SERCOS
the automation bus

CANopen

C 1400

Universal



- 1x200...240VAC
- For LinMot P10/AC servomotors
- 100 programmable motion profiles
- 255 storable motion commands
- Interface for incremental or absolute sensors
- RS232 configuration interface



EtherCAT

ETHERNET
POWERLINK

SERCOS
the automation bus



ME OUT

ME IN

CMD OUT

CMD IN

Force DHCP
Bootstrap
ME CAN Term
CMD CAN Term
CMD RS485 Term
Ain2 Pull Down

+5VDC
Sens A
Sens /A
Sens B
Sens /B
Sens Z
Sens /Z
Sens Alarm
GND
Hall Sw U
Hall Sw /U
Hall Sw V
Hall Sw /V
Hall Sw W
Hall Sw /W

Error
Warning

CONFIG RS232

X4.11 QuickStop, PTC2
X4.10 IO, PTC1
X4.9 IO, LIM+
X4.8 IO, LIM-
X4.7 IO, HSW
X4.6 IO, TRIG
X4.5 IO, CAP
X4.4 IO, AN
X4.3 IO, /BRK
X4.2 +24VDC
X4.1 DGND

ID HIGH (5-8)

ID LOW (1-4)

RT BUS Error

REAL TIME ETHERNET

ME OUT

ME IN

CMD OUT

CMD IN

6 Force DHCP
5 Bootstrap
4 ME CAN Term
3 CMD CAN Term
2 CMD RS485 Term
1 Ain2 Pull Down

1 +5VDC
9 Sens A
2 Sens /A
10 Sens B
3 Sens /B
11 Sens Z
4 Sens /Z
12 Sens Alarm
5 GND
13 Hall Sw U
6 Hall Sw /U
14 Hall Sw V
7 Hall Sw /V
15 Hall Sw W
8 Hall Sw /W

Error
Warning

CONFIG RS232

X4.11 QuickStop, PTC2
X4.10 IO, PTC1
X4.9 IO, LIM+
X4.8 IO, LIM-
X4.7 IO, HSW
X4.6 IO, TRIG
X4.5 IO, CAP
X4.4 IO, AN
X4.3 IO, /BRK
X4.2 +24VDC
X4.1 DGND

ID HIGH (5-8)

ID LOW (1-4)

RT BUS Error

REAL TIME ETHERNET

Process Monitoring

With the new «Process Monitoring» application, LinMot is taking the next step in the direction of Industry 4.0. The user is able to define up to 16 monitoring windows in which the measured variables that are decisive for the process can be monitored, visualised and evaluated. Due to the

fast cycle time of the drive, individual measuring points are recorded at the highest sampling rate to guarantee the user the best possible resolution. Initial evaluation results are available from as little as 5 ms and can be further processed by the higher-level control system.

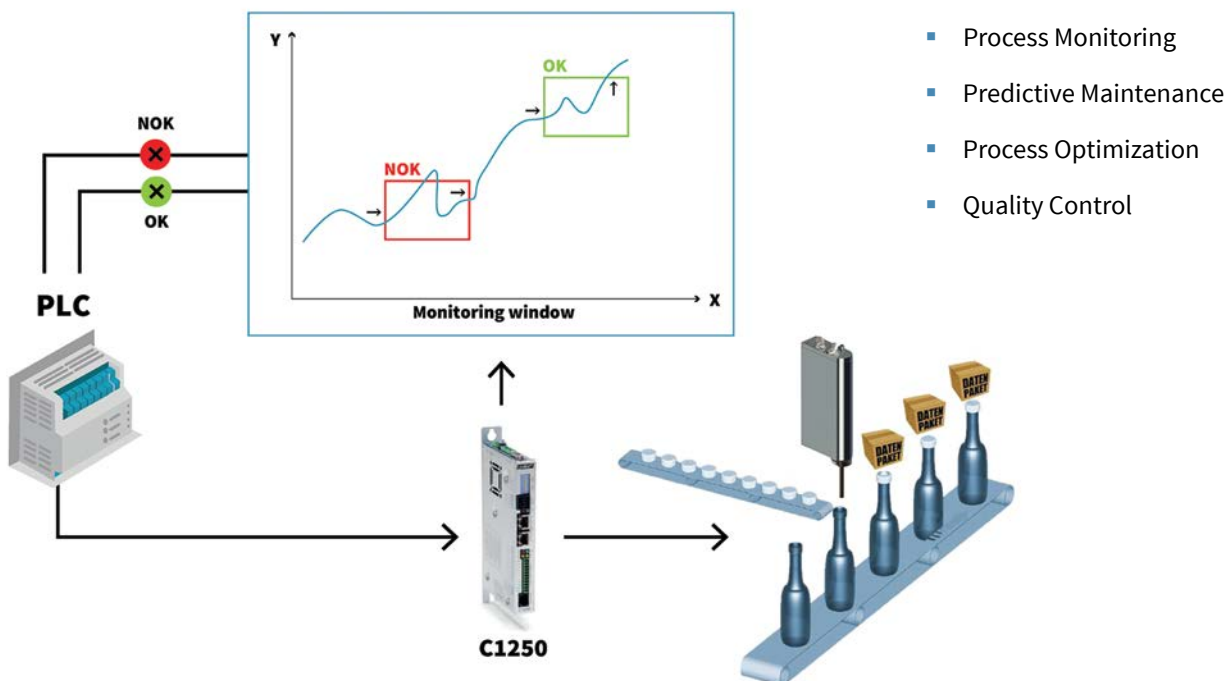

Real-time data evaluation, independent of bus cycle time

Easy communication with the PLC

Increased production time and quality control

Up to 16 different, individually configurable monitoring windows

Designed for high-precision processes

No additional hardware required

Functional Safety

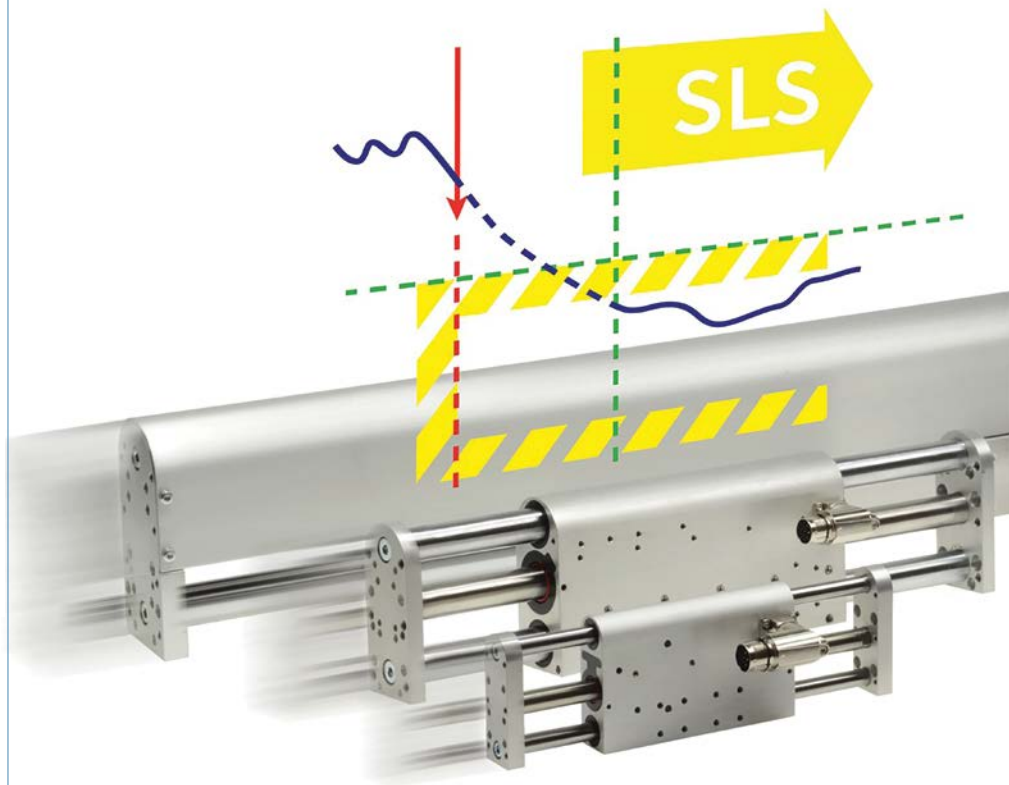

- Complete, certified functional safety package from a single source
- Reliable, matching components and tested interfaces
- Safety linear motors with integrated, safety position sensors
- C1251-2S drive with integrated safety functions, and safe digital IO's
- Up to SIL 2 (EN 61508) and PL d (EN ISO 13849)
- One cable solution
- Same design for both safety and non-safety products

STO:	Safe Torque Off
SS1:	Safe Stop 1
SS2:	Safe Stop 2
SOS:	Safe Operating Stop

SLS:	Safe Limited Speed
SBT:	Safe Brake Test
SBC:	Safe Brake Control

LinMot Talk and LinMot Designer

Correctly size and monitor your linear motors

Complete control in configuration and operating modes

A linear drive application starts with the correct sizing of the linear motor. LinMot provides designers with an easy to use tool. LinMot Designer calculates the parameters required to select a drive and linear motor for a given motion sequence and load case, and relates them to the selected linear motor and servo drive.

Using LinMot Talk PC interface, the engineer can configure LinMot servo drives. The motors are also monitored during operation and the current motion sequences are analyzed (monitoring).

The integrated control panel gives the user direct access to the control and status words, as well as all commands that are invoked by the upper-level controller.



Design with LinMot Designer

- Specification of all global data
- Simulation of motions
- Determination of kinematic data
- Calculating motor power draw
- Approval of selected motor
- “Efficiency” tab that compares energy use between pneumatic cylinders and linear motors
- Sizing of Linear and Rotary motors

Configuration with LinMot Talk

- Drive and motor configuration
 - Configuration of application data
 - Create and save motion sequences
 - Controller optimization and status monitoring
 - Records and measurements with oscilloscope
 - Reading error history (error management)
-

Commissioning by a click

SPS Libraries and Programming Examples

LinMot Drives have all common fieldbus interfaces available for connection to a master controller.

In order to realize simple control concept integration, extensive function blocks and programming examples are provided for the customer. These function blocks allow for direct and quick LinMot drive integration.

The function blocks run standard functions as well as commands such as drive parameterization and configuration directly from the controller. The complete drive configuration of the corresponding axis is thus stored on the controller.

Maintenance or replacement can be easily realized via automatic drives detection and configuration over the communication bus. Thus manual and time-consuming configuration of the drives in case of failure is eliminated.

Proven technology to get moving quickly.

Configuration via PnP

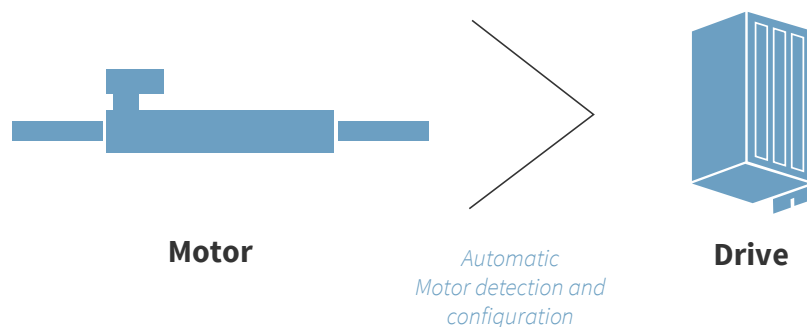

Configuration via PLC

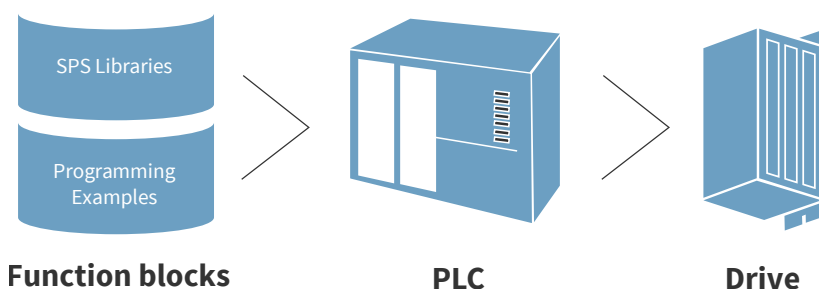

Automatic motor configuration

Plug & Play technology, well established in the computer industry, is now used by LinMot for automatic device detection commissioning linear motors.

With Plug & Play motors, the parameters are saved directly to the stator. The servo drive reads these values when it boots up, and sets the parameters

accordingly. This eliminates the selection of the required model parameters from an extensive library.

Immediately after installing and connecting the cable, the motor can be moved immediately. Without having the configuration software to boot, first commands can be sent directly by the PLC control. Initial commissioning and replacement with a motor are thus very simple operations.

The right linear motor for every application



Food products



LinMot drives provide machine builders with optimal components for putting the manufacturing and packaging processes in motion in the food products industry. In combination with freely programmable motion parameters via the drive, the motors provide a high level of flexibility for various applications.

- Beverage filling
- Single and multiple closures
- Weight products
- Metering products
- Sorting using pushers or pull noses
- Reject products
- Cutting food products
- Packaging
- Placing products in packages
- Sealing
- Compressing
- etc.



Textile Machines



Modern weaving machines profit by the LinMot technology for years. In the machines, the motors are used for example for laying and positioning of additional threads. Especially when it comes to the stitch weaving, they take over the work of the stitch drive axes. Also for the precise winding of textile yarn, the machine engineers prefer to use linear motors. For this purpose, LinMot has programmed a complete function block that controls the entire winding process and can be easily started by the PLC.



Wood Processing



Linear technology ensures automatic step width adjustment, for example, in order to guarantee optimal material cuts. In addition to this, there are other possible applications.

- Automatic step width adjustment
- Precise cuts for endless materials
- etc.
- Rapid transport of drills
- Handling of material



Semiconductors & Electronics

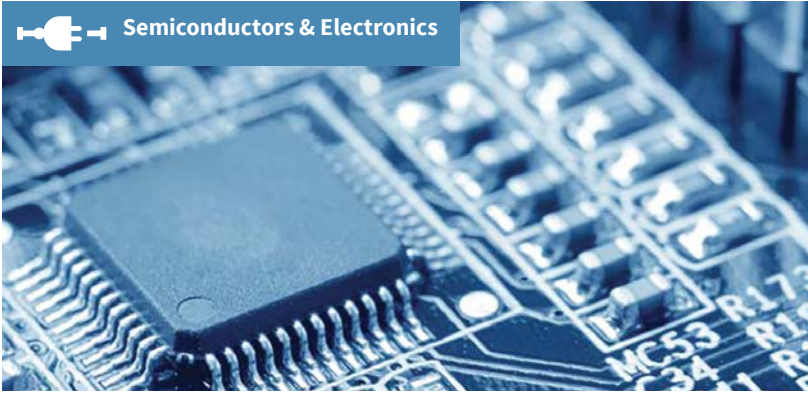

In the semiconductor industry, the availability of systems and machines is an absolute requirement.

Modern electronics production must be capable of handling frequent product changes. With innovative drive solutions from LinMot and intelligent drive and controls components, production and conveying applications can be implemented effectively.

- Front-end machines
- Back-end machines
- Wafer handling
- Semiconductor handling
- Semiconductor inspection machines
- Semiconductor packaging machines
- Populating machines
- Flying probe testers
- Depaneling
- CD/DVD production systems & packaging machines
- etc.



Automotive



Linear drive components from LinMot lead to greater flexibility and productivity in the automotive industry. They can effectively provide not only functional and durability tests for automobiles, but also applications all along the manufacturing process. This especially includes applications in the areas of assembly, material management, and error inspection.

- Functional and durability tests
- Assembling
- Material management
- Error inspection
- etc.



Laboratory Automation



Automated workstations or laboratory equipment require a high level of flexibility and reproducibility from the selected drives.

LinMot components meet these requirements and are quiet, low-maintenance, clean-room-compatible and ensure smooth movements. The unusually compact LinMot drives are ideal for use in automated equipment because they take up very little space themselves.

- Handling
- Loading and unloading
- Material management
- Error inspection
- etc.



Medical & Pharmaceutical



The range of applications for linear drives in the medical and pharmaceutical sector is very broad.

For handling blood samples, counting and filling pills, or packing challenging medications, LinMot drive components provide a high level of dynamics and precision for implementing these tasks.

The hygienic design of the linear motors makes it possible to cleanly process these highly sensitive products in accordance with clean room regulations.

- Flexible filling stations
- Metering and counting
- Insertion
- Closures
- Pressing of closures
- Carton packaging
- Labeling
- Pick and place systems
- Product handling and palletizing
- Blister & tray handling
- Packing systems for blisters & trays
- etc.



Handling & Assembling

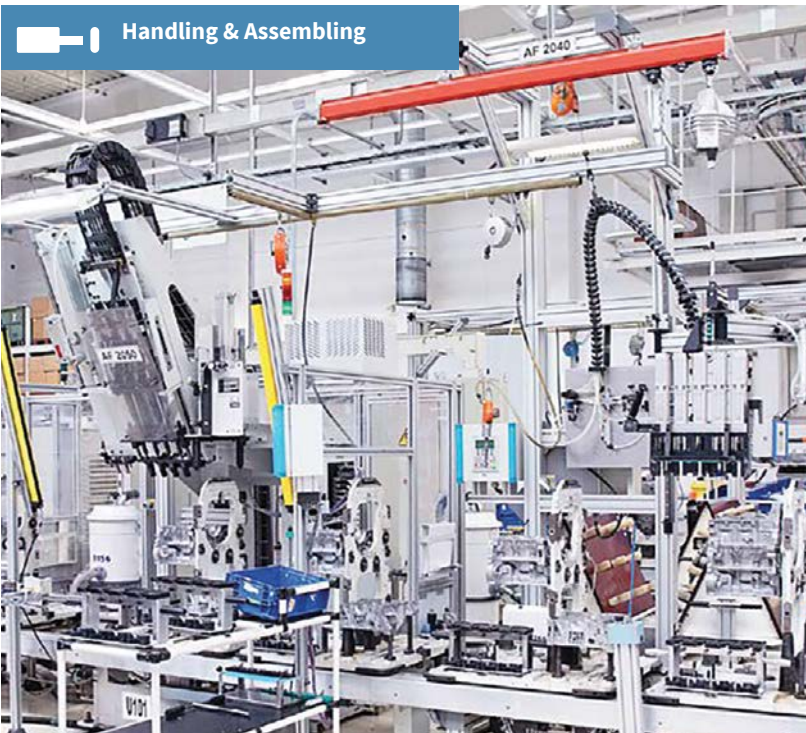

In addition to an increased flexibility, a modern facility requires a maximum production speed and a secure traceability in the form of a complete electronic process documentation.

With freely programmable and highly dynamic linear motors, the plant engineer finds the optimal components for a modern production machine.

- Feeders
- Transfer systems
- Pick & place modules
- Palletizing units
- Stacking units
- XY tables
- Precision pressing
- Sorting systems
- Automatic screwdrivers
- Metering units
- Gluing stations
- Quality assurance
- Test fixtures
- Camera positioning
- Lighting positioning
- etc.



Printing & Labelling



Sensitive products can be printed more quickly using linear motor technology, because the printing process is performed using position, speed, and force control. The force impacts associated with pneumatic solutions do not occur.

In general, the freely programmable force and motion profiles lead to decisive process improvements in comparison with other types of drives, opening up many fields of application.

- Inspection systems
- Paper feeding
- Decorating
- Color mixing systems
- Pad printing
- Screen printing
- Doctor blade controls
- Labeling
- etc.



Packaging



The highly dynamic and durable drives ensure high productivity and availability. The programmable drives can be adapted quickly to new products and types of packaging at the push of a button, providing continuous monitoring of motion parameters.

In many of these applications, linear motors are used as replacements for pneumatic cylinders, in order to make machines and systems more flexible, productive, and reliable while simultaneously reducing the energy cost for each package.

- Insertion
- Feeding
- Guiding
- Carton packaging
- Sealing
- Labeling
- Unloading
- Discharge
- etc.

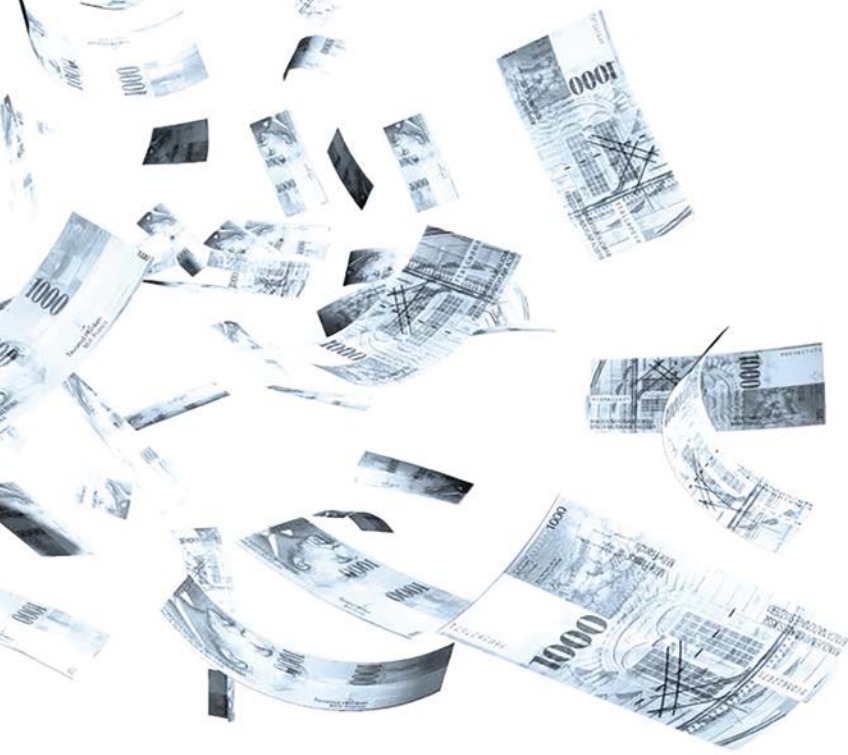

Electric linear actuators are superior to pneumatic cylinders in many applications.

Electricity instead of air

Energy and cost savings - Unique Advantages of electric linear motion technology

Machine design engineers have found numerous situations where linear direct drives provide distinct advantages over pneumatic actuators. These include: If more than two end positions are needed, if the positions are to be changed by software, if running synchronously with a main drive is required or the dynamics / life of a pneumatic cylinder is simply no longer sufficient.

Due to the high operating costs of pneumatic cylinders, linear motors may also prove to be a cost efficient alternative in simple point to point motions even with only two end positions.

This is especially true when the motions are in a cyclic operation and carried out regularly. Many times pneumatic cylinders must be oversized due to the speed and load conditions. In many cases the pneumatic cylinder energy and maintenance costs exceed the investment costs within a few weeks.

A typical cost comparison shows the impressive cost savings with LinMot linear motors.

Cost comparison example

Application

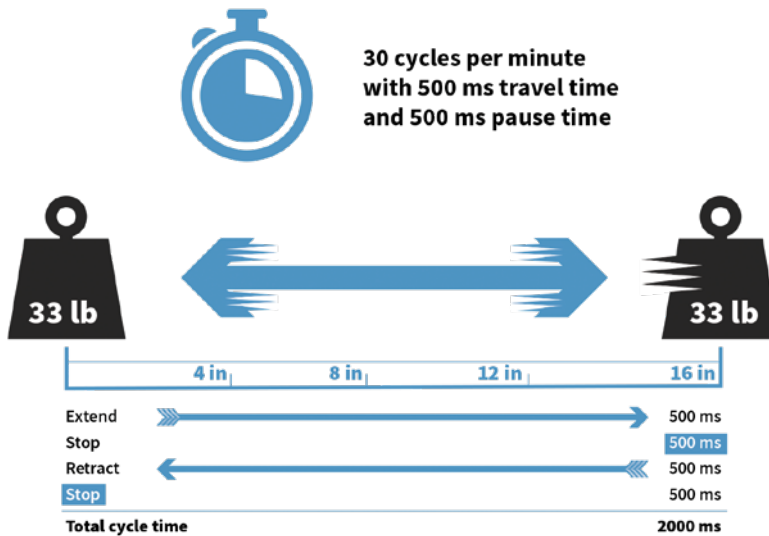

Parameter

Positioning time:	500 ms
Required acceleration:	10 m/s ²
Required speed:	1 m/s
Expected period of operation:]8000 h

Comparison of technology

Linear Motors

- Acceleration work is performed only during 100 ms.
- At standstill, no energy is expended.
- At a constant speed, only energy to overcome the friction is used.
- Kinetic energy is stored in the DC link capacitor of the servo drives.
- The measured power consumption for this application is 92 W on average.**

Pneumatic cylinder

- For the required mass and velocity a piston diameter of 50 mm is required.
- During the entire moving time, compressed air power is required.
- Dampers absorb the energy during braking. The energy cannot be stored.
- Due to the cylinder diameter, the stroke and the cycle time the annual air requirement equals 150.000 Nm³ per year.
- Pneumatic manufacturers list production costs for compressed air at 0.025 EUR/Nm³.

Energy costs

- At a current price of 0.12 € / kWh and 8000 hours of operation, **the annual energy cost is € 96.**
- With production costs of 0.025 EUR / Nm³ and an air consumption of 150.000 Nm³.
- The annual compressed air costs are 3.750.- €.**

Total cost comparison and CO₂ emissions

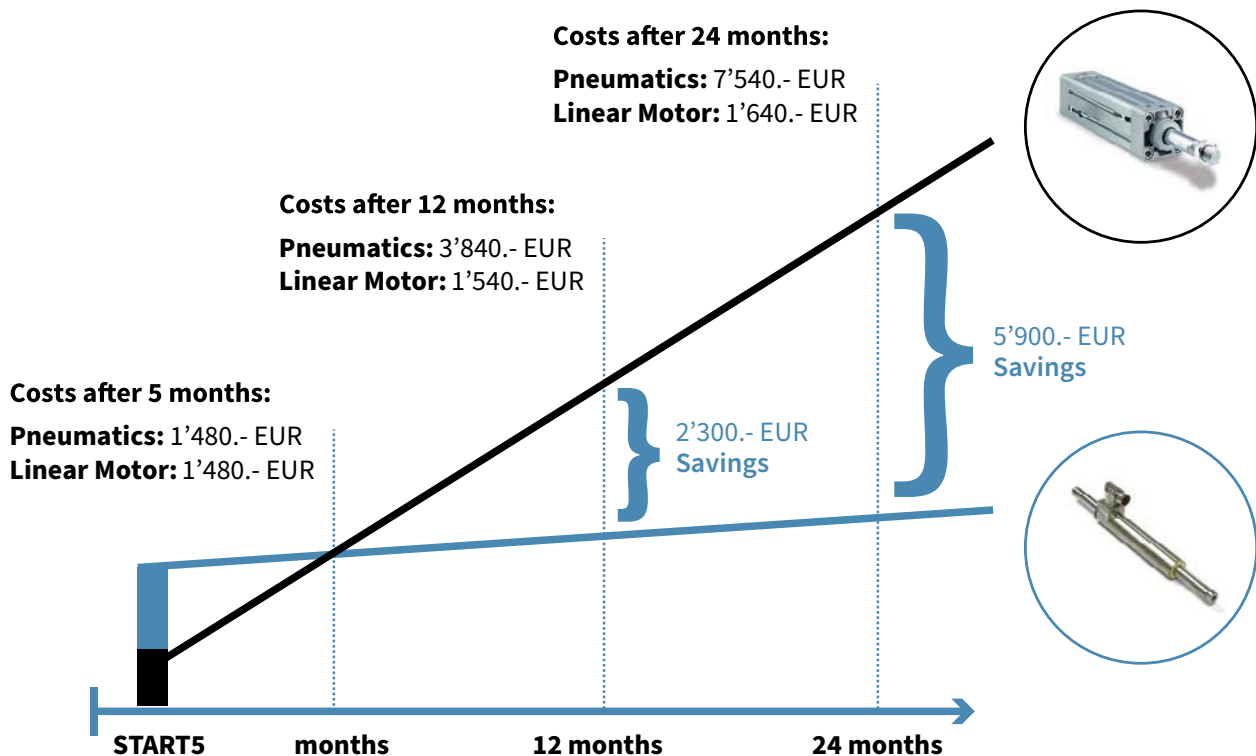

The initial costs of a linear direct drive system including all components (cables, converters, etc.) required for the operation are higher than the initial costs for a pneumatic actuator system (incl. valves, hoses, etc.). But by accounting for the significantly lower energy costs of linear motors, these initial costs are recovered in less than half a year. After this time, the cost savings are realized as lower operating costs and increased profit margins. The operating energy costs of pneumatics exceed their initial investment costs after only three months.

CO₂ emissions can be drastically reduced by switching to an electric linear drive providing another huge benefit. The energy of 24,000 kWh, which is additionally required by the pneumatic cylinder in this sample calculation, results in an annual output of 12,000 kg CO₂. This calculation takes into account the German energy mix of 500g CO₂ / kWh.

Thus, the CO₂ record speaks clearly: A change to electric direct drives!



Competence

Everything from one source

Support



As the world`s leading manufacturer of industrial tubular linear motors, we use our knowledge and innovation to provide customized solutions.

Seeking the optimal solution of specific drive tasks our application engineers offer exceptional support to the customer. Our customers can rely on years of production experience for the implementation and production for customer specific drive solutions.

Innovation

Through continuous development and investment and with the input of our worldwide sales consultants, engineers and partners, we are able to offer our customers commercially viable new products at attractive prices.



Production



The standardized LinMot and MagSpring products are manufactured via self-designed production facilities. This guarantees rapid product availability even in larger quantities while simultaneously allowing for maximum flexibility and customizations. The highly automated production facilities ensure constant high quality products.

“

Seeking optimal solutions for specific drive tasks LinMot application engineers provide exceptional customer support.

Logistics



LinMot and MagSpring products are standardized products, which are typically supplied from stock and available worldwide. Currently more than 2000 different drive and motor combinations are in stock and available within 48 hours worldwide.

Quality

Quality control starts with the checking of incoming material and continues into production all the way through the final burn-in testing before delivery. All LinMot linear motors are subjected to a 24-hour burn-in before delivery. For long-term quality assurance, LinMot products are labeled with a unique serial number on the Stator, on its electronic nameplate and in the Servo Drive.



Contact



Europe / Asia Headquarters

NTIAG
LinMot & MagSpring

Bodenaeckerstrasse 2
CH - 8957 Spreitenbach

☎ +41-(0)56-419 91 91
📠 +41-(0)56-419 91 92

✉ office@linmot.com
🏠 www.linmot.com

North / South America Headquarters

LinMot USA Inc.

N1922 State Road 120, Unit 1
Lake Geneva, WI 53147

☎ 262-743-2555
📠 262-723-6688

✉ usasales@linmot.com
🏠 www.linmot-usa.com/

ALL LINEAR MOTION FROM A SINGLE SOURCE

Europe / Asia Headquarters

NTI AG - LinMot & MagSpring
Bodenaeckerstrasse 2
CH-8957 Spreitenbach
Switzerland

☎ +41 56 419 91 91

✉ office@linmot.com

🏠 www.linmot.com

North / South America Headquarters

LinMot USA Inc.
N1922 State Road 120, Unit 1
Lake Geneva, WI 53147
USA

☎ 262.743.2555

✉ usasales@linmot.com

🏠 www.linmot-usa.com

🌐 Visit www.linmot.com/contact/ to find your local sales and support contact.

LinMot[®]